

## **Picoseconds Dark Pulse Zirconia-Yttria-Aluminium-Erbium-doped Fiber Laser**

**Arni Munira Markom<sup>1</sup>, Ahmad Razif Muhammad<sup>2</sup>, Zakiah Mohd Yusoff<sup>3</sup>, Mukul Chandra Paul<sup>4</sup> and Sulaiman Wadi Harun<sup>5</sup>**

Faculty of Electrical Engineering, Universiti Teknologi MARA, Cawangan Johor, Kampus Pasir Gudang, 81750 Malaysia  
arnimunira@uitm.edu.my

Computational Optics Research Group, Advanced Institute of Materials Science, Ton Duc Thang University, District 7, Ho Chi Minh City, Vietnam  
ruxxzif@gmail.com

Faculty of Electrical Engineering, Universiti Teknologi MARA, Cawangan Johor, Kampus Pasir Gudang, 81750 Malaysia  
zakiah9018@uim.edu.my

Fiber Optics and Photonics Division, CSIR-Central Glass and Ceramic Research Institute, 196 Raja S.C. Mullick Road, Kolkata 700032, India  
paulmukul@hotmail.com

Department of Electrical Engineering, Faculty of Engineering, University of Malaya, 50603 Kuala Lumpur, Malaysia.  
swharun@um.edu.my

### **ABSTRACT**

A 3.4 picoseconds dark pulse fiber laser was successfully generated using Zirconia-Yttria-Alumina-Erbium-doped fiber laser (Zr-EDF) cavity with graphene oxide as saturable absorber. The laser cavity was 11.5 m long with the group delay dispersion of  $-0.04 \text{ ps}^2$ . The multiwavelength optical spectrum provides 1 MHz repetition rate and 67.8 dB optical signal to noise, defines the high stability of the dark pulse. A strong nonlinearity and high birefringence of the Zr-EDF and GOSA cause the pulse turn down to dark region. An ultrafast dark pulse is demand due to low interference and excellent stability in the existence of noise that are required for high efficiency and accuracy demanding by biomedical devices.

**KEYWORDS:** Dark pulse, Zirconia fiber, Zr-EDF, Fiber Laser and Graphene Oxide

## 1 INTRODUCTION

Advances in ultrafast light sources have been applied as essential tools in a wide range of fields, such as laser physics, nanotechnology and medicine. Dark pulse was discovered 40 years ago in 1973 and attracts so much attention since then [1]. It defined as a train of intensity dips in the intensity of a continuous wave (CW) background of the laser emission. Moreover, dark solitons are widely used in optical signal trapping, atomic trapping, optical sensing and optical communication due to their advantages such as lower threshold [2], more stable in background of noise and spread slowly in presence of fiber loss, less interaction between neighboring dark solitons for their bright counterparts [3-4] and less sensitive on Gordon-Haus effect in a time jitter for both numerically and analytically [5].

The advance technology nowadays driven the biomedical devices to generate high-tech and ultrafast fiber laser due to its reliability and efficiency. Demand for extremely precise control to avoid thermal damage and infection during surgical process in human body. The need of innovation fiber for rare-earth material doping to develop an excellent stability of dark pulse fiber laser due to the cost of human life.

## 2 OBJECTIVES

- To develop dark pulse fiber laser using a homemade Zirconia-Yttria-Aluminium-Erbium-doped Fiber towards biomedical applications.
- To generate an ultrafast pulse duration in picoseconds with high stability of optical signal to noise ratio (OSNR) with employment graphene oxide saturable absorber (GOSA).

## 3 SIGNIFICANCES

- Avoid detrimental effect to achieve high optical gain up to 41 dB.
- Capable to provide dark pulse with simple method in ring cavity.
- Wideband transmission from C-to extended L-band region from 1550 to 1620 nm.
- Short gain medium of 1 m length that suitable for compact devices.
- Provide an ultrafast fiber laser in 3 picoseconds.

## 4 METHODOLOGY

An experimental setup of the mode-locked Zr-EDF fiber laser is shown in Fig. 1. The total length cavity is approximately 11.5 m including the 1 m length of Zr-EDF. A 980 nm laser diode is used to pump the cavity via 980 nm/1550 nm wavelength division multiplexing (WDM) coupler. An isolator is inserted before WDM to provide uni-directional operation and GOSA is used. The GOSA is placed before an intra-cavity polarization controller (PC) which is used to adjust the polarization state of the light inside the cavity to induce the intra-cavity filtering effect. The output is extracted via a 5% fiber output coupler, and measured by an optical spectrum analyzer (OSA, AQ6317C) and oscilloscope (OSC, WaveRunner 104MXI) with a high-speed photodetector.

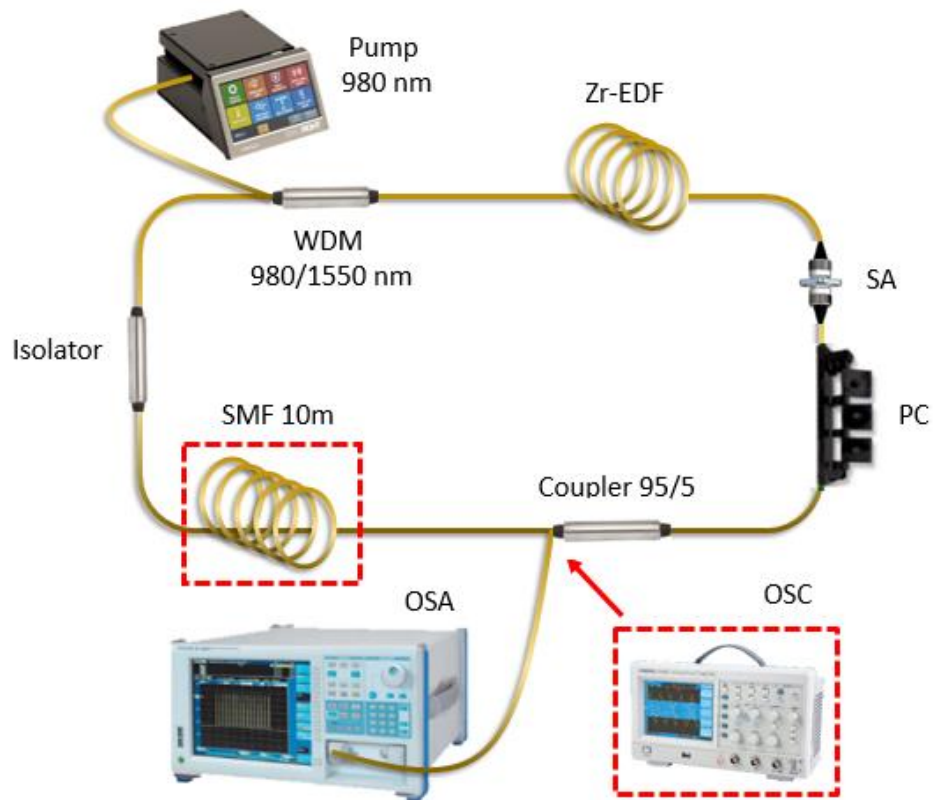

Fig. 1 Experiment Setup for the dark pulse fiber laser.

## 5 RESULT

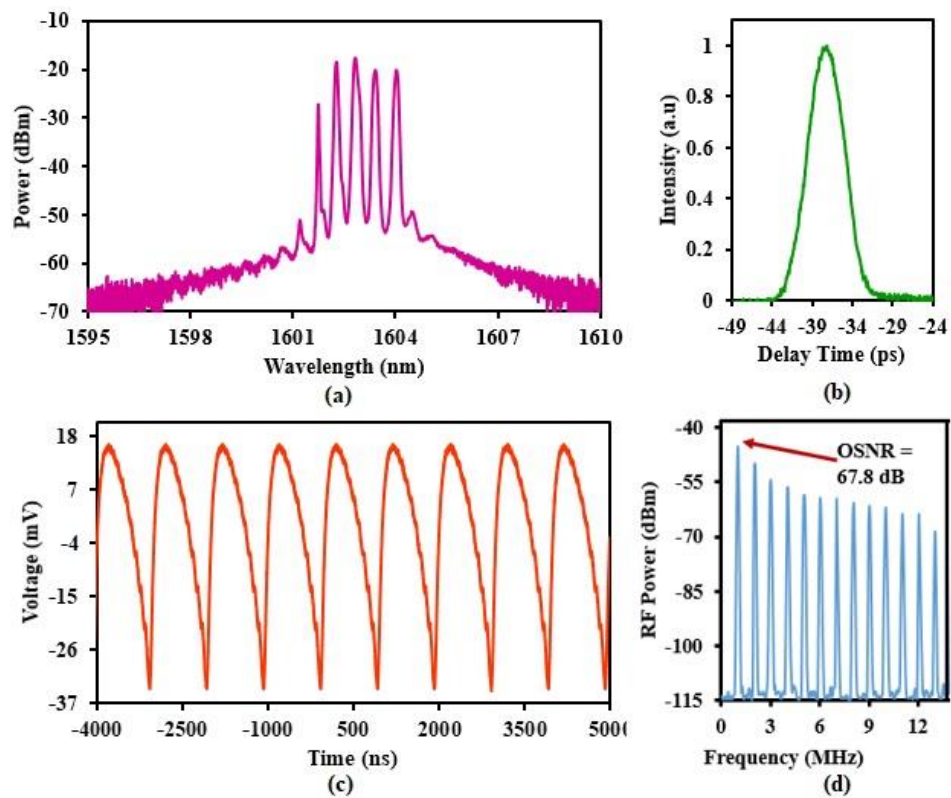

Fig. 2 (a) Optical spectrum (b) Pulse duration (c) Dark pulse train (d) OSNR

Fig. 2 shows the result of the dark Zr-EDF pulsed fiber laser. A multiwavelength with 5 lasing from 1602 nm to 1605 nm with uniform spacing of 0.6 nm is shown in Fig. 2 (a) measured by OSA. By using auto correlator, 3.4 ps is measured for pulse duration as illustrated in Fig. 2 (b). Then, the dark pulse train measured by OSC is shown in Fig. 2 (c) whereas as high as 67.8 dB OSNR in Fig. 2 (d) measured by radio frequency (RF) device. The high OSNR translates the high stability dark pulse in the cavity of experimental setup.

## 6 CONCLUSION

Summarizing, we experimentally demonstrated a dark pulse fiber laser in L-band regions from 1602 nm to 1604 nm wavelengths by employing graphene oxide saturable absorber (GOSA) as a saturable absorber. Furthermore, we report the new discovery of dark pulse shape with pulse duration down to 3.4 ps. Zirconia-Yttria-Aluminium-Erbium-doped fiber has a very high Erbium concentration with the help of GOSA, it produce a strong nonlinearity and high birefringence cause the picoseconds dark pulse fiber laser. A fundamental repetition rate of 1 MHz is obtained at the pump power of 79.58 mW. Then, the highest pump energy of 3 pJ is observed at the corresponding repetition rate.

## REFERENCES

- [1] Agrawal, G. P. (2000). Nonlinear fiber optics. In *Nonlinear Science at the Dawn of the 21st Century* (pp. 195-211). Springer Berlin Heidelberg.
- [2] Gredeskul, S. A., & Kivshar, Y. S. (1989). Generation of dark solitons in optical fibers. *Physical review letters*, 62(8), 977.
- [3] Zhao, J. Q., Wang, Y. G., Yan, P. G., Ruan, S. C., Zhang, G. L., Li, H. Q., & Tsang, Y. H. (2013). An L-band graphene-oxide mode-locked fiber laser delivering bright and dark pulses. *Laser Physics*, 23(7), 075105.
- [4] Hasegawa, A., & Tappert, F. (1973). Transmission of stationary nonlinear optical pulses in dispersive dielectric fibers. II. Normal dispersion. *Applied Physics Letters*, 23(4), 171-172.
- [5] Kivshar, Y. S., Emplit, P., Hamaide, J. P., & Haelterman, M. (1994). Gordon-Haus effect on dark solitons. *Optics letters*, 19(1), 19-21.