

4TH EDITION

**E-EXTENDED  
ABSTRACT**

**INTERNATIONAL  
AGROTECHNOLOGY  
INNOVATION  
SYMPOSIUM (i-AIS)**



## COPYRIGHT

### INTERNATIONAL AGROTECHNOLOGY INNOVATION SYMPOSIUM (i-AIS)

19 June 2023

Faculty of Plantation and Agrotechnology UiTM Cawangan Melaka Kampus Jasin

Published 2023

Faculty of Plantation and Agrotechnology

Universiti Teknologi MARA Cawangan Melaka Kampus Jasin

77300 Merlimau Melaka.

E-EXTENDED ABSTRACT of the INTERNATIONAL AGROTECHNOLOGY INNOVATION SYMPOSIUM (i-AIS) (4<sup>th</sup> EDITION)

Mode of access Internet

<https://sites.google.com/view/ais2023/publication>

Perpustakaan Negara Malaysia Cataloguing -in – Publication Data

## ORGANIZING COMMITTEE

Program Advisor	:	Ts. ChM. Dr. Wan Zuraida Wan Mohd Zain
Program Director	:	Dr. Noer Hartini Dolhaji
Program Secretary	:	Nurul Izzatiafifi Ismail
Program Treasurer	:	Nur' Amira Hamid
Program Registration	:	Siti Aisha Na'illa Che Musa
Program Judging	:	Nur Atiqah Zaharullil Nur Wajihah Mohd Nawi
Program Webmaster	:	Ts. Dr. Siti Fairuz Nurr Sadikan
Program Certificate		Nurul Wahida Ramli
Program Human Contribution		Nur Nabila Huda Aziz
Program Protocol		Siti Nur Atikah Abu Samah
Program Publication		Dr. Mohd Zuli Jaafar
Program Logistic		Muhammad Nuruddin Mohd Nor
Program Technical		Khawarizmi Mohd Aziz

## STUDENT COMMITTEE

Mohammad Ali Kamaruddin  
Nurul Huda Nabilah Ramlee  
Siti Nor Arifah Abd Halim  
Nuraliah Aqilah Ayuni Mohamed  
Mohamad Khairul Haziq Mohamad Fauzi  
Nur Wajihah Mohd Nawawi  
Mohammad Hafis Ayub  
Aiman Haziq Arifin  
Amyra Hazwani Ghazali  
Mohamad Syamil Mohd Nor  
Mohammad Najmuddin Suriani  
Nur Syafiqah Aina Azmi  
Muhammad Aidil Ikhwan Kamarudin  
Nur Muhammad Ameiriqwan Ahmad Faiza  
Muhammad Faiz Zulazmi  
Mohd Azri Aiman Zulkifli  
Diana Asykin Kamaruddin  
Nor Elin Balqis Ismail  
Nursyasya Razalil  
Muhammad Ismadanial Rozi  
Muhammad Amir Asyraf Azman  
Mohamad Zairy Zailan

## EDITORIAL BOARD

### *Patron*

Prof Ts Dr Azhan Hashim @ Ismail

### *Advisors*

Prof Madya Ts. Dr. Fazleen Abdul Fatah

Ts. ChM Dr. Wan Zuraida Wan Mohd Zain

Dr. Noer Hartini Dolhaji

### *Editors*

Dr. Mohd Zuli Jaafar

Dr. Wan Zuraida Wan Mohd Zain

Dr Noer Hartini Dolhaji

Muhammad Aidil Ikhwan Kamarudin

Abdul Quddus bin Puteh

Nurul Izzatiafifi Ismail

## ABOUT FACULTY OF PLANTATION AND AGROTECHNOLOGY

The Faculty of Plantation and Agrotechnology was established in 2010 at Universiti Teknologi MARA (UiTM). The mission of the faculty is to play the vital role of producing well-trained professionals in all areas of plantation and agriculture-related industries at national and international levels.

Bachelor of Science (Hons) Plantation Technology and Management is a three-year program that strongly emphasizes the various aspects of Production Technology, Management, and Information Technology highly sought after by the agricultural and plantation sectors. Students in this program will be fully trained to serve as professionals in the plantation sector and related industries. They will have ample opportunities to fulfill important positions in the plantation industry such as plantation executives. This program provides a strong balance of technology and management courses essential for the plantation industry such as management of plantation crops, soil fertility, plantation management operation, plantation crop mechanization, and agricultural precision. As an integral part of the program, students will be required to undergo industrial attachment to gain managerial skills in the plantation industry.

The faculty is highly committed to disseminating, imparting, and fostering intellectual development and research to meet the changing needs of the plantation and agriculture sectors. With this regard, numerous undergraduate and postgraduate programs have been offered by the government's intention to produce professionals and entrepreneurs who are knowledgeable and highly skilled in the plantation, agriculture, and agrotechnology sectors.

## PREFACE

International Agrotechnology Innovation Symposium (i-AIS) is a platform to be formed for students/lecturers/ staff to share creativity in applying the knowledge that is related to the world of Agrotechnology in the form of posters. This virtual poster competition takes place on the 1st of December 2022 and ends on the 8th of January 2023. This competition is an assessment of students in determining the level of understanding, creativity, and group work for the subject related to agrotechnology and being able to apply it to the field of Agrotechnology. The i-AIS 2022 program takes place from December 1, 2022, to January 8, 2023. The program was officiated by the Dean of the Faculty of Plantation and Agrotechnology, namely Prof. Madya Ts. Dr. Azma Yusuf. The program involves students from faculties of the Faculty of Plantation and Agrotechnology (FPA) and HEP participating in i-AIS 2022, namely, the Faculty of Education and Pre-Higher Education. This program involves the UiTM student and some of the non-UiTM students which come from the international university and the local university. Two categories are contested, namely UiTM and non-UiTM. To date, students from these programs have shown remarkable achievements in academic performance and participation in national as well as international competitions.

This competition is an open door for the students and lecturers to exhibit creative minds stemming from curiosity. Several e-content projects have been evaluated by esteemed judges and that has led to the birth of this E-Poster Book. Ideas and novelties are celebrated, and participants are applauded for displaying ingenious minds in their ideas.

It is hoped that such an effort continues to breed so that there is always an outlet for these creative minds to grow.

Thank you.

Dean  
On behalf of the Organizing Committee  
Conference Chair  
Universiti Teknologi MARA  
Faculty of Plantation and Agrotechnology  
<http://fpa.uitm.edu.my>

## TABLE OF CONTENTS

1.	COPYRIGHT .....	i
2.	ORGANIZING COMMITTEE .....	ii
3.	STUDENT COMMITTEE .....	iii
4.	EDITORIAL BOARD .....	iv
5.	ABOUT FACULTY OF PLANTATION AND AGROTECHNOLOGY .....	v
6.	PREFACE .....	vi
7.	TABLE OF CONTENTS .....	vii
8.	GOLD AWARD.....	1
9.	VACUUM LOOSE FRUIT COLLECTOR.....	2
10.	3 IN 1 COCOA POST-HARVEST MACHINE .....	6
11.	THE UTILIZATION OF GREEN BANANA (MUSA ACUMINATA X MUSA BALBISIANA) FLOUR IN THE DEVELOPMENT OF KEROPOK LEKOR .....	9
12.	THE UTILIZATION OF DATE PALM FRUITS POWDER IN THE DEVELOPMENT OF PASTA.....	18
13.	THE UTILIZATION OF JACKFRUIT SEED FLOUR IN THE DEVELOPMENT OF MALAYSIAN FISH CRACKER.....	25
14.	THE USE OF BAMBOO SHOOTS IN THE DEVELOPMENT OF PLANT- BASED PATTIES.....	38
15.	SMART FERMENTATION SHALLOW BOX .....	44
16.	PHYTOCHEMICAL AND BIOLOGICAL ANALYSIS OF MEDICINAL PLANT, <i>Apium graveolens</i> (CELERY): A REVIEW .....	48
17.	CALCIUM BIOFORTIFIED SCHIZOPHYLLUM COMMUNE AND ITS RELATION TO STUNTED GROWTH AMONG CHILDREN .....	51
18.	REAL-TIME TEMPERATURE AND HUMIDITY MONITORING OF STINGLESS BEE COLONIES USING IOT TECHNOLOGY .....	59
19.	THE ANTIBACTERIAL PROPERTIES OF SCHIZOPHYLLUM COMMUNE AND THEOBROMA CACAO L .....	63
20.	PALM OIL CARTON PACKAGING .....	69
21.	SILVER AWARD .....	73
22.	COCOA SOLAR DRYER.....	74
23.	SUSTAINABLE PLANT WASTE MANAGEMENT (BANANA PEEL POWDERED FERTILIZER) .....	77
24.	ANANAS COMOSUS SMART SENSOR GRADING .....	79
25.	FRUIT SANITIZE POSTHARVEST .....	82
26.	LOOSE FRUITS REMOVER.....	87
27.	PADDY-TECH MACHINES .....	93



28.	OIL PALM CREAMPUFF .....	96
29.	BUD-KIT AS A CLASSROOM LEARNING TOOL.....	101
30.	PORTABLE PEPPER COLLECTER .....	105
31.	SOLAR RICE THRESHER.....	107
32.	THEOBROMA TECHNOLOGY (DRYER).....	113
33.	BRONZE AWARD.....	116
34.	SOLAR SEED DRYER WITH AUTOMATIC TRACKING .....	117

# SMART FERMENTATION SHALLOW BOX

Andelline Liliana Anak Roland<sup>1</sup>, Patricia Lenya Anak Arin<sup>1</sup>, Syarifah Nurazreen Binti Wan Makhdar<sup>1</sup>

<sup>1</sup>*Faculty of Plantation Management and Agrotechnology, UiTM Kota Samarahan, Sarawak Branch.*

*Corresponding author e-mail : [patricialenya00@gmail.com](mailto:patricialenya00@gmail.com)*

**ABSTRACT** - Cocoa must undergo fermentation process first before it can produce a nice flavor and aromas. According to research, without fermentation process, the cocoa bean potentially to become slaty and fully purple (Khairul & Kajol, 2015). Some of the farmers are neglecting the fermentation process and directly to drying process since they want to gain profit in a short period and save their time. Traditionally, cocoa is being fermented manually either by using banana leaves or boxes and the process needs 7 days to complete thus create problems among farmers as mentioned above. Therefore, feature such as temperature controller, rotator and expansion of the box size are improvised as value added. All process such as controlling the temperature, turning, and drying can be done simultaneously by only using 1 box thus this can save time, cost, resources, and energy. Besides, the Smart Fermentation Shallow Box enable the fermentation process can be shorten to 5 days. In overall, Smart Fermentation Shallow Box surely give a good impact to the farmers and cocoa industry. Smart Fermentation Shallow Box product also have the potential to attract people that often face lots of problems during the fermentation process. Lastly, all factors such as time, energy, and cost can be saved.

**Keywords:** cocoa, fermentation process, shallow box, technology.

## INTRODUCTION

Cocoa (*Theobroma cacao*), had been cultivated in Malaysia for more than two centuries and was first found in a garden of Malacca in the year of 1778. Currently, Malaysia has become the second largest producer country in Asia and being the 6<sup>th</sup> largest in the world. In 2021, it has contributed about RM1.64 billion to the GDP of Malaysia. For that reason, it is essential to maintain the status of Malaysia as the one of the main cocoa producers. In order to sustain the cocoa quality, it is important to improve the fermentation process since it was the primary step in producing the cocoa-based product.

Fermentation process is the exothermic process that involves the microbial activities in mucilaginous pulp in producing alcohol, acid and release heat, and simultaneously triggers biochemical reactions in the cocoa bean (De & Weckx, 2016). The objectives of fermentation process are to produce a good chocolate flavor precursor, easier the drying process and prevent the breakdown of the cocoa fat. Basically, fermentation process is carried out whether in heap and shallow box. The traditional shallow box consists of three boxes and required the labor to turn and mixed it periodically in two days along the 7 days of the fermentation process and this consume time and susceptible to the contamination. Therefore, in order to make the fermentation using shallow box more effective and ergonomic, we create a smart shallow box which only use one shallow box that has a dimension of 4.5 m x 3.5m x 2.5m. It is made from 'cengal' wood and feature with temperature indicator, rotator, and jute sheet as the substitute for the banana leaves.

## MATERIAL AND METHOD

The material used in producing this product are 'cengal' hardwood, temperature controller, rotator, and jute sheet. This idea was inspired during the class discussion regarding the common problem in fermentation process. Therefore, we are doing further research using secondary data from article, news, and books section. According to research, fermentation is not favourable among some farmers due to the longer period, hence they directly to the drying process (Khairul & Kajol, 2015). However, these practices lead to the loss of flavor and aromas of cocoa. As a consequent, the quality of the cocoa become lower and decrease the price.

Flowchart of the fermentation process by using Smart Fermentation Shallow Box is as below:

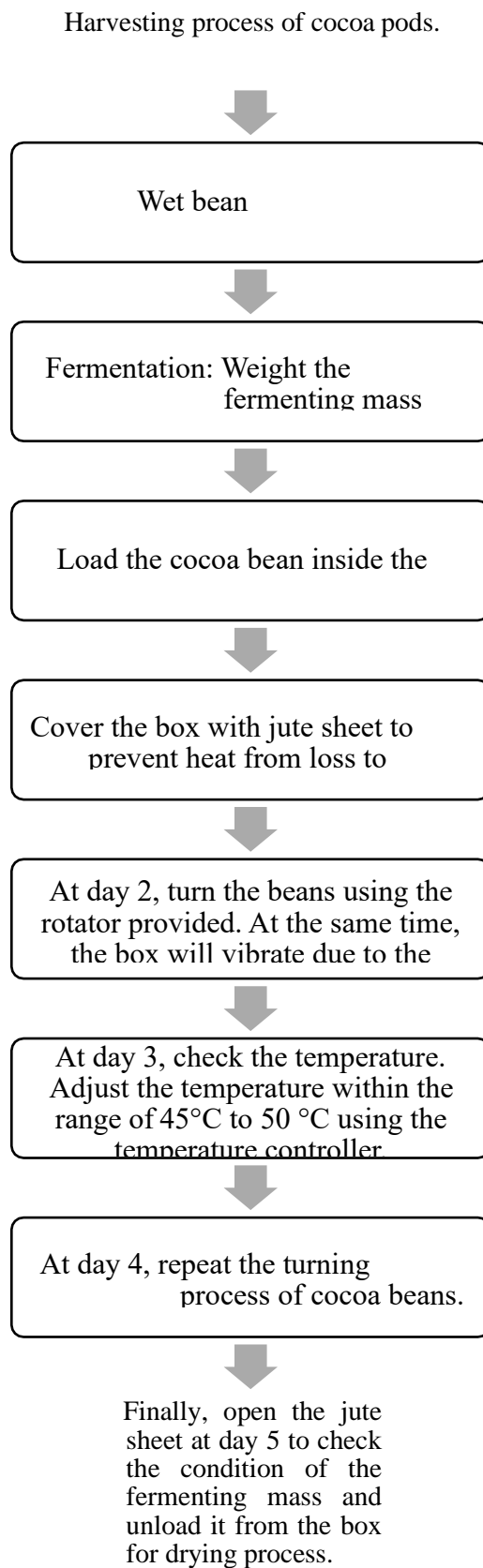

## RESULTS AND DISCUSSION

From our discussion, it was found that Smart Fermentation Shallow Box can ferment the cocoa beans more efficiently compared to the existing shallow box. Besides, this new product can control the moisture and temperature during the fermentation without consume time and labour's energy because it was feature with temperature controller which functional to control and display the temperature inside the box. Besides, it also has ergonomic design which is rotator where the farmers can just turning the box by using rotator provided instead of using common method such as shallow box that requires transferring process of the cocoa. Furthermore, this innovation product can save resource as all the process such as temperature controller, turning and drying can be done simultaneously by only using 1 box. In addition, production cost of the product is also low and the price is quite affordable for the farmers or smallholder that manage the cocoa plantation. The cost of production is estimated around RM490.67 which more cheaper than the existing fermentation cocoa beans which is approximately RM2829.29 as it needs 3 box for the fermentation process. Last but not least, Smart Fermentation Shallow Box is more save time compared to shallow box because the average fermentation period in Smart Fermentation Shallow Box is only took 5 days compared to the common shallow box which took 7 days for the bean to fully fermented. To summarize, Smart Fermentation Shallow Box is an innovation product that improvise from the shallow box that currently practice in the cocoa industry.

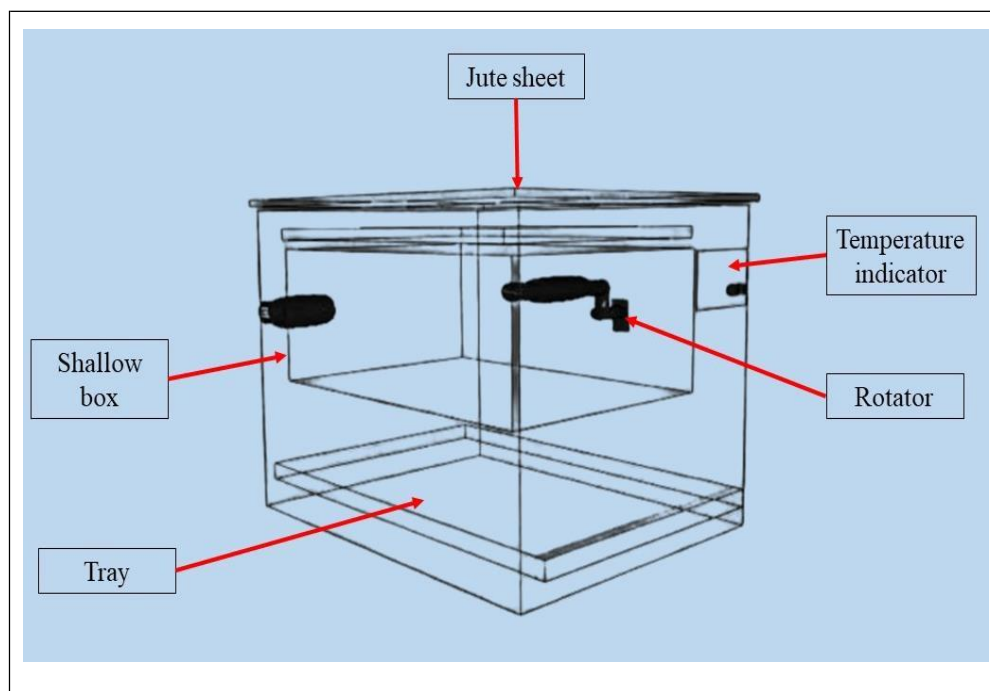

**Figure 1. The Sketch Of The Smart Fermentation Shallow Box.**

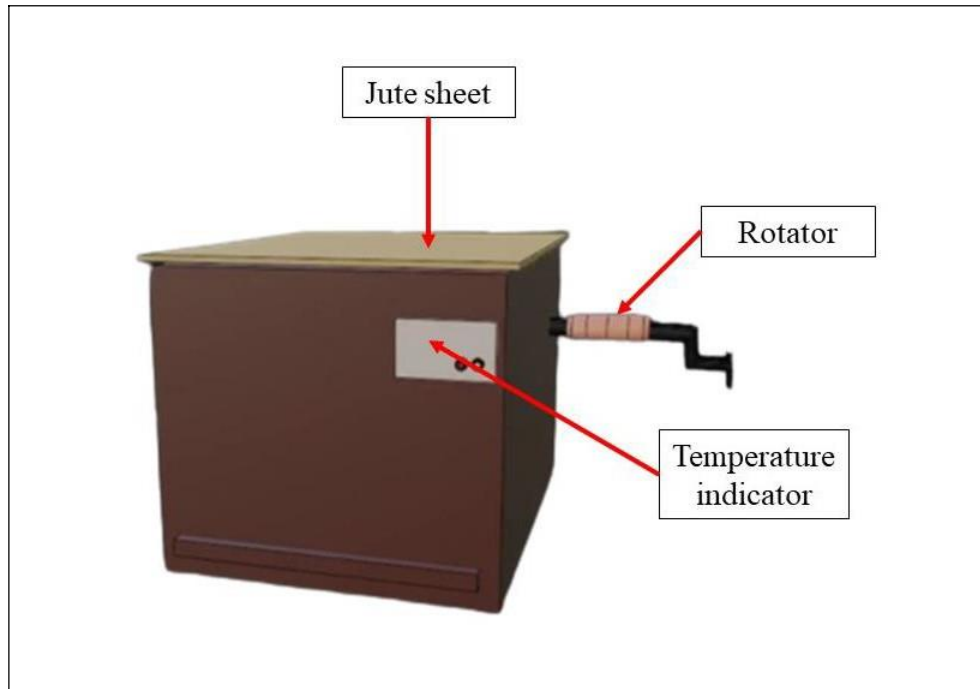

**Figure 2. Smart Fermentation Shallow Box In 3D View.**

## **CONCLUSION**

Cocoa industry can be improved in the future by creating more technology. In overall, our product, surely give a good impact to the farmers and cocoa industry. With the existing of our product, agriculture sector is expected can be improved due to modern technology which has been introduced. Smart Fermentation Box product might also have the potential to attract people that often face lots of problems during the fermentation process. Lastly, all factors such as time, energy, and cost can be saved.

## **REFERENCES**

- [1] De Vuyst, L., & Weckx, S. (2016). The cocoa bean fermentation process: from ecosystem analysis to starter culture development. *Journal of Applied Microbiology*, 121(1), 5-17.
- [2] Sulaiman, K. B., & Yang, T. A. (2015). Color characteristics of dried cocoa using shallow box fermentation technique. *Inter Scholar Sci Res Innov*, 9, 1277-1281.

E-EXTENDED ABSTRACT of the INTERNATIONAL AGROTECHNOLOGY INNOVATION SYMPOSIUM  
(i-AIS) (4th EDITION)



FAKULTI PERLADANGAN DAN AGROTEKNOLOGI UiTM JASIN

(online)



UNIVERSITI  
TEKNOLOGI  
MARA

Fakulti  
Perladangan dan  
Agroteknologi

