



اَبُو سَيْتِي تَيْكُونُو لِي مَارَا
UNIVERSITI
TEKNOLOGI
MARA

BUILDING DEPARTMENT

FACULTY OF ARCHITECTURE, PLANNING AND SURVEY

UNIVERSITI TEKNOLOGI MARA

(PERAK)

APRIL 2012

STUDENT DECLARATION

I hereby stated that this report is my own work, except for extract and summaries for which the original references stated herein through the Intensive Practical Training which started from 12th November 2012 till 12th April 2012 at NS BINA, Senawang, Negeri Sembilan. It is also one of the passing rules for DBN307, and to fulfil a part of the conditions to obtain the Diploma in Building.

Name : Nur Nabilah Hannah Bt Ghazali

UiTM ID No : 2010562637

Date : 7th March 2013

**DEPARTMENT OF BUILDING
FACULTY OF ARCHITECTURE, PLANNING AND SURVEY
UNIVERSITI TEKNOLOGI MARA
(PERAK)**

APRIL 2013

This practical report is prepared

by

NUR NABILAH HANNAH BT GHAZALI

2010562637

Entitled

MECHANICAL AND ELECTRICAL INSTALLATION

Is accepted as a part of condition to graduate with Diploma in Building

Report supervisor

Pn. Suryani bt Ahmad

Practical coordinator

En. Noor Azam b Yahya

Program coordinator

Sr. Dr. Hayroman B Ahmad

ACKNOWLEDGEMENT

Alhamdulillah, praise to Allah s.w.t for his guidance, this Practical Training Report can be completed in time. Next, the most appreciation and thank you to everyone that has spending their time giving guidance and cooperation for me in completing this report. Thank you to the Manager, En. Noor Iskandar B Mohamad Noor, the project manager; Miss Siti Zulaikhah bt Murat, practical training coordinator; En. Noor Azam b Yahya, Miss Suryani bt Ahmad; the supervisor lecturer, the visiting lecturer; Sr. Dr. Hayroman b Ahmad, all the lecturers of building department and also to my parents and site supervisors. Thank you also to my classmate and others that could not be stated here.

Thank you.

ABSTRACT

This report is explained about the installation of mechanical and electrical (M&E) for office project. It is produced through 5 months practical training experience. This report is divided to several sections and is started with the company and construction project background. Actually, the M&E installation is not easy as what it seems as it include many works and complicated process. Here also simply explained about the types and main components of the installation. Then, here also briefly explained the methods used which involved excavating and installing works. During the construction, there were few problems related to the process methods and there are few suggestions that are believed could solve those problems. As a result, this report could practically explain the process and the method of mechanical and electrical installation to readers.

CONTENT	PAGE	
Acknowledgement	i	
Abstract	ii	
Table of Content	iii	
List of Table	iv	
List of Diagram	v	
List of Abbreviation	vi	
List of Shortened Word	vii	
CHAPTER 1.0	INTRODUCTION	
1.1	Introduction	1
1.2	Objectives	1
1.3	Scope of Study	1
1.4	Method of Study	2
CHAPTER 2.0	COMPANY BACKGROUND	
2.1	Introduction	3
2.2	Company profile	4
2.3	Organization Chart	17
2.4	List of Project	
2.4.1	Completed Project	18-
2.4.2	On-going Project	20
CHAPTER 3.0	CASE STUDY (M & E INSTALLATION)	
3.1	Introduction	21
3.2	Project Background	22
3.3	Case Study	23
CHAPTER 4.0	CONCLUSION AND SUGGESTIONS	45
LIST OF REFERENCES	46	
Appendix A	3D perspective drawing	
B	SAINS project monthly report cover	
C	Electrical Infrastructure Layout	
D	Lighting and Power Layout	
E	Electrical Schematic Diagram	
F	CCTV and Access Door Layout	
G	Air-Cond. and Fire Fighting Layout	
H	General Arrangement & Single Line For DB-L	
I	Starlite Products and systems catalogue cover	

LIST OF TABLE

Table 2.2	Company Profile	5
Table 2.3	Organization Chart	6
Table 2.3.1	Director's Profile	7
Table 2.3.2	Site Manager's Profile	9
Table 2.3.3	Mechanical Project Manager's Profile	11
Table 2.3.4	Contract Manager's Profile	13
Table 2.3.5	Civil Project Manager's Profile	15
Table 2.3.6	Human Resource Manager's Profile	18

LIST OF DIAGRAM

Diagram 2.2.1	Company Logo	4
Diagram 3.1	Excavating work for G.I. duct installation	24
Diagram 3.1	GI duct laid inside the excavated soil	24
Diagram 3.1	The cross section view of power cable	24
Diagram 3.1	The electrical meter box	25
Diagram 3.1	The main distribution board	25
Diagram 3.2	Moulded circuit current breaker	27
Diagram 3.2	Residual circuit current breaker	27
Diagram 3.3	Fluorescent fitting	28
Diagram 3.3	PLC down light	29
Diagram 3.3	Fluorescent fitting c/w Daikon diffuser	29
Diagram 3.4	Emergency lighting	30
Diagram 3.5	Galvanized steel 'EXIT' sign	30
Diagram 3.6	Package unit air conditioner	31
Diagram 3.6	Unventilated split air-conditioner	32
Diagram 3.7	Air conditioner installation work	34
Diagram 3.8	The communicating & internet wires	35
Diagram 3.8	The wires distribution in electrical junction box	35
Diagram 3.9	Fibre optic	36

Diagram 3.10	Example of keypad reader access controller	37
Diagram 3.10	Proximity card reader	38
Diagram 3.11	Example of access door wiring	40
Diagram 3.12	Charged coupled device camera	41
Diagram 3.13	Dry powder ABC and CO2 type extinguisher	42
Diagram 3.13	Photoelectric smoke detector	43
Diagram 3.13	Cross section of smoke detector	44

ABBREVIATION

1	UiTM	Universiti Teknologi MARA
2	MDB	Main Distribution Board
3	MCCB	Moulded Circuit Current Breaker
4	RCCB	Residual Circuit Current Breaker
5	MCB	Miniature Current Breaker
6	RCD	Residual-current Devices
7	DBL	Distribution Board for Lighting
8	DBS	Distribution Board for Switches
9	RCBO	Residual Current Breakers with Overcurrent protection
10	CO ₂	Carbon Dioxide

CHAPTER 1

INTRODUCTION

1.1 Introduction

Mechanical and Electrical installations are vital to comfort, safety, productivity of works and profit gained by an associations or companies. In this report, it emphasizes the installation of mechanical and electrical of the whole building. The project is about ***“Cadangan Tambahan Dan Ubahsuai Pejabat Syarikat Air Negeri Sembilan Sdn. Bhd. (SAINS), Daerah Tampin, Negeri Sembilan Darul Khusus”***.

1.2 Objectives

The objectives are :

- i) To identify the methods of mechanical and electrical installation works.
- ii) To identify the method of main electrical supply installation.

1.3 Scope of study

The scope of study of this project includes the mechanical and electrical installation work at the construction site from the early stages until the end of the installation.

1.4 Method of study

This report is accomplished through several methods:

i. Reference

In doing this practical report, the author refers to books which are related to the topic chosen. This is to increase knowledge and understanding of how the works go, before seeing itself at the site in practical. As a result from reading, lots of ideas existed.

ii. Interviews

Interviewing some individuals is done when the theories are not similar or convincing as what it should be at the construction site. So, the persons who work at the construction site are the main sources of this information.

iii. The electronic media

This method is used when the authors need further explanation about the topic. When by reading and interviewing have been done, electronic media is needed in improving description and examples.

iv. Observations

Through observation, the author gathered lots of information in both way, theory and practical. This way also helps the author to understand better and reduce the questions thinkable.

CHAPTER 2

COMPANY BACKGROUND

2.1 Introduction

NS BINA has been registered on 22nd February 2002. It has started its operation throughout Seremban. This company compete with other companies to uphole indigenous peoples in construction sector.

This company's uniqueness first can be seen among it's technical staff which are experienced in varying aspects in construction sector. Each management staff here are those who are qualified with academic in construction sectors and there are also staffs with experience in handling 'A' class project. These factors give an advantage to the company in interacting with various situations and also ease the communication process.

During operating, NS BINA had never failed to accomplish all projects entrusted to them and mostly accomplished timely. Besides that, the quality of their work meets the customers and also the project consultant. In addition, NS BINA has also been given trust and the opportunity to complete the government D-class works. Their motto is not to disappoint their customers, and will perform their best. Customers satisfaction is their goal.

2.2 Company Profile

Company's Name	NS Bina
Company Registration No	001331984-H
Owner Registered	Noor Iskandar Bin Mohamad Noor
Status	Indigenous (Bumiputera)
Business Address	No. 6061-1, Jalan SJ 5/1, Taman Seremban Jaya, 70450 Seremban, Negeri Sembilan Darul Khusus.
Workshop Address	No 17, JlnBSS 1/2B, Bandar Seremban Selatan, 71450 Sg Gadut, Seremban, N. Sembilan
Telephone number	
Fax No.	06 - 678 8381
Type Of Business	Sole proprietorship
Registration Date	22nd January 2002
Type Of Business	Building Construction, Roads, Sign Boards, Landscapes, Bridges and Steel Works.

2.2.1 Company Logo



2.3 Organization Chart

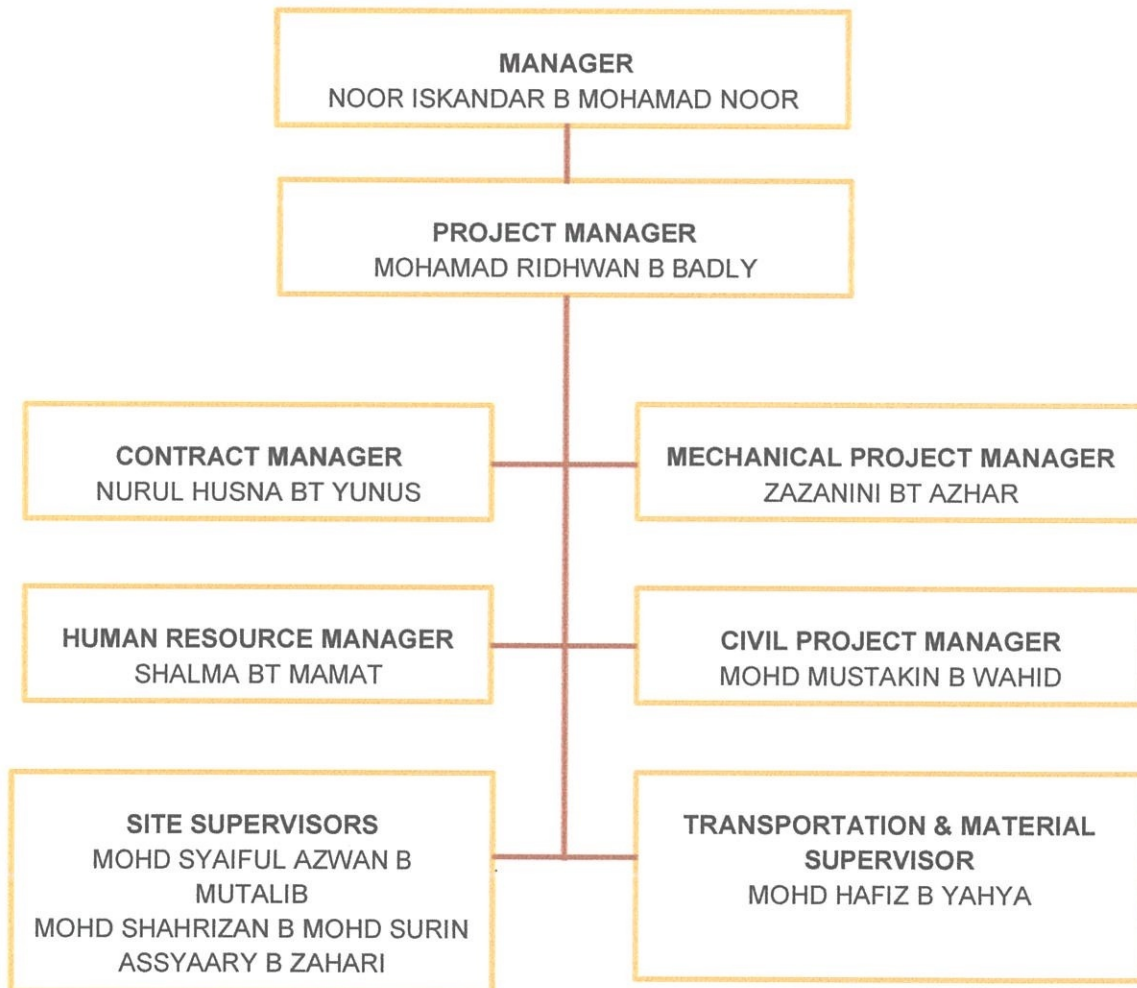

2.3.1 Director's Profile

Name	Noor Iskandar B Mohamad Noor
Id Number	
Colour	Blue
Sex	Male
Date Of Birth	24th September 1979
Address	No 367, Rumah Rakyat Dusun Nyior, 70100 Seremban, Negeri Sembilan Darul Khusus.
Race	Malay
Nationality	Malaysia
Academic Achievement	Diploma in Civil Engineering, UiTM
Work Experience	<ul style="list-style-type: none">- Quantity Surveyor Assistant for design, build and completing Seri Kembangan Police Station. (RM 6 Million)- Site Manager for designing, build and completing 'Pusat Pertahanan Awam, JPAM Seremban. (RM 9 Million)

Certified True Copy

80E, Tingkat 1, Jalan Rasah,
70300 Seremban,
Tel: 06-7628013



UNIVERSITI TEKNOLOGI MARA

Dengan ini disahkan bahawa

Noor Iskandar Bin Mohamad Noor

adalah mempunyai **NOOR ISKANDAR BIN MOHAMAD NOOR**

Fakulti Kejuruteraan Awam

*dan setelah lulus segala peperiksaan serta memenuhi
segala syarat program yang ditetapkan oleh Universiti
adalah dengan ini diumumkan*

Diploma Kejuruteraan Awam

pada **16** *tarikh* **November** *tahun* **2000**

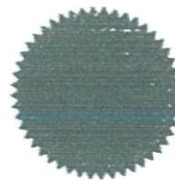

Nah Canselor

Pendaftar

2.3.2 Site Manager's Profile

Name	Mohamad Ridhwan B Badly
Id Number	
Colour	Blue
Sex	Male
Date Of Birth	1st August 1979
Address	PT 1246, Jalan Taratai, Taman Marida, Senawang, 70450 Seremban, Negeri Sembilan Darul Khusus.
Race	Malay
Nationality	Malaysia
Academic Achievement	Degree in Civil Engineering, UTM
Work Experience	- Civil engineer in 'Kejuruteraan Sepakaat Gemilang Sdn Bhd' 2009 - Project engineer in 'Ikatan Inovasi Sdn Bhd' 2008



UNIVERSITI TEKNOLOGI MALAYSIA

BAHAWASANYA SENAT TELAH MENGANUGERAHKAN

IJAZAH

SARJANA MUDA KEJURUTERAAN
(AWAM)

DENGAN KEPUIJAN KELAS KETIGA

KEPADA

MOHAMAD RIDHWAN BIN BADLY

NAIB CANSOLOR

PENDAFTAR

DEKAN,
FAKULTI KEJURUTERAAN AWAM

14 OGOS 2004

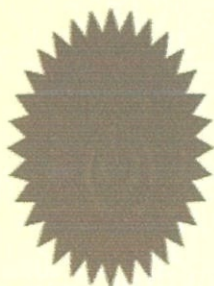

2.3.3 Contract Manager's Profile

Name	Nurul Husna Bt Mohd Yunus
Id Number	
Colour	Blue
Sex	Female
Date Of Birth	30th December 1986
Address	No 1, Lorong SK 2/2, Taman Sri Kasih, 70450 Seremban, Negeri Sembilan Darul Khusus.
Race	Malay
Nationality	Malaysia
Academic Achievement	Diploma in Building Services Engineering (Politeknik Sultan Salahuddin Abdul Aziz Shah, Shah Alam)
Work Experience	- Practical (Primary Horizon Sdn Bhd)



KEMENTERIAN PENGAJIAN TINGGI MALAYSIA

ADALAH DENGAN INI DISAHKAN BAHAWA

DIPLOMA

INI DIANUGERAHKAN KEPADA

**NURUL HUSNA BINTI MOHD YUNUS
NO KP:**

SALINAN DIKUTIP SAH

Pengarah M. Aminon
Jabatan Pengajaran
JER. Seremban

SETELAH MEMUASKAN LEMBAGA PEPERIKSAAN DAN PENGANUGERAHAN
SIJIL / DIPLOMA POLITEKNIK DENGAN MEMENUHI SEMUA KEHENDAK KURSUS

KEJURUTERAAN PERKHIDMATAN BANGUNAN

DI **POLITEKNIK
SULTAN SALAHUDDIN ABDUL AZIZ SHAH
SHAH ALAM**

Ketua Pengarah
Jabatan Pengajaran Politeknik
dan Kolej Komuniti

Tarikh: 23 Julai 2007

Pengarah
Politeknik Sultan Salahuddin
Abdul Aziz Shah



2.3.4 Civil Project Manager's Profile

Name	Mohd Mustakin B Wahid
Id Number	
Colour	Blue
Sex	Male
Date Of Birth	12th December 1987
Address	No 39, Kampung Lakai, 72400 Simpang Durian, Negeri Sembilan Darul Khusus.
Race	Malay
Nationality	Malaysia
Academic Achievement	Diploma in Civil Engineering (Politeknik Port Dickson), 'Sijil Kejuruteraan Awam' (Politeknik Sultan Idris Shah) CADD Architecture Industrial Training Institute.
Work Experience	- Practical (Mohd Salleh Construction & Majlis Daerah Jelebu)

REGISTRATION NO: 1020520

SERIAL NO: LPP05CSB/2209/208



INDUSTRIAL TRAINING INSTITUTE

THE INSTITUTE HEREBY CONFERS

MOHD MUSTAKIN B WAHID KP: [REDACTED]



MANPOWER DEPARTMENT
MINISTRY OF HUMAN RESOURCES MALAYSIA

INDUSTRIAL TECHNICIAN CERTIFICATE

CADD ARCHITECTURE

ON THIS 05 DAY OF NOVEMBER YEAR 2007



DATE ISSUED 17 MAY 2007

DIRECTOR GENERAL
MANPOWER DEPARTMENT

DIRECTOR
INDUSTRIAL TRAINING INSTITUTE
PEDAS



KEMENTERIAN PENGAJIAN TINGGI MALAYSIA



ADALAH DENGAN INI DISAHKAN BAHAWA

DIPLOMA

INI DIANUGERAHKAN KEPADA
MOHD MUSTAKIN BIN WAHID
NO K/P :

SETELAH MEMUASKAN LEMBAGA PEPERIKSAAN DAN PENGANUGERAHAN
SIJIL / DIPLOMA POLITEKNIK DENGAN MEMENUHI SEMUA KEHENDAK PROGRAM

KEJURUTERAAN AWAM

DI POLITEKNIK PORT DICKSON

NEGERI SEMBILAN DARUL KHUSUS



Ketua Pengarah
Jabatan Pengajaran Politeknik

Pengarah
Politeknik Port Dickson

TARIKH: 2 FEBRUARI 2012

2.3.5 Human Resource Manager's Profile

Name	Shalma Bt Mamat
Id Number	
Colour	Blue
Sex	Female
Date Of Birth	25th December 1986
Address	15 RMD, Kem Senawang, 70450 Seremban, Negeri Sembilan Darul Khusus.
Race	Malay
Nationality	Malaysia
Academic Achievement	Bachelor In Landscape Architecture (UPM)
Work Experience	- Enumerator (UPM) - Accountant (Antop Sdn Bhd)

UNIVERSITI PUTRA MALAYSIA



Adalah disahkan bahawa

SHALMA BINTI MAMAT

*sesudah memenuhi syarat-syarat yang diwajibkan
oleh Senat telah dianugerahkan Ijazah
Bachelor Senibina Landskap*

KEPUJIAN KELAS KEDUA RENDAH

Red Cancellor

President

03 Jun 2011

2.4 Projects List

2.4.1 Completed Projects

1. *'Cadangan Menaiktaraf Longkang, Pembentung Dan Lain-Lain Kerja Berkaitan KFC, Jalan Tun Dr. Ismail, Seremban'. (RM 544,095.60)*
2. *'Cadangan Merekabentuk, Membina Dan Menyiapkan Ubahsuai Untuk Pusat Mel Di Pejabat Pos Besar Bukit Baru, Melaka'. (RM179,820.00)*
3. *'Cadangan Meroboh Dan Membina Semula Bangunan Tambahan Di Bahagian Hadapan Pejabat Pos Kuala Kedah, Jalan Raya Pekan, 06600 Kuala Kedah'. (RM 110,000.00)*
4. *'Cadangan Merekabentuk, Membina Dan Menyiapkan Kerja-kkerja Ubahsuai Dalam Di Pejabat Pos Jitra, Kedah'. (RM 175,000.00)*
5. *'Cadangan Membina Sebuah Rumah Banglo Setingkat Di atas Lot 97 H.M (M) 144 Sungai Pupuh, Ampangan Seremban, N.Sembilan'. (RM 220,850.00)*
6. *'Cadangan Ubahsuai Dalam Di Tingkat Bawah Dan Tingkat Satu Di Pusat Poslaju Senawang, Negeri Sembilan'. (RM 198,000.00)*
7. *'Cadangan Tambahan Dan Ubahsuai Ruang Dalam Untuk Jabatan Kejuruteraan Di Tingkat 2, Wisma Majlis Perbandaran Seremban, Negeri Sembilan'. (RM 1,000,110.00)*
8. *'Cadangan Membina Gelanggang Serbaguna 'Rubberised Hard Court' Di Kampus INTEC Seksyen 17 Dan Kolej Cemara Seksyen 18 UiTM Malaysia, Shah Alam'. (RM 1,161,545.00)*

9. *'Cadangan Membina Bangunan Asrama, Stadium Tertutup dan Surau serta Kerja-kerja Menaiktaraf di Kolej Komuniti Rompin, Pahang Darul Makmur secara Sub dari Cekal Teknokrat Sdn Bhd'. (RM 6,705,270,40)*
10. *'Cadangan Membina Dan Menyiapkan Sebuah Dewan Orang Ramai Di Taman Angsamas, Mambau, Daerah Seremban, Negeri Sembilan Darul Khusus'. (RM 1,790,082.00)*
11. *'Cadangan kerja-kerja Pembaikan Awam Selama Dua Tahun Di Zon C2, Universiti Teknologi MARA (UiTM), Shah Alam, Selangor'. (RM 1,000,000.00)*
12. *'Renovation Works and Mechanical and Electrical Works at Pejabat Tanah Dan Daerah Rembau dan Daerah Port Dickson, Negeri Sembilan Darul Khusus Secara Sub Dari Aboy Teguh Enterprise'. (RM 290,000.00)*
13. *'Cadangan Tambahan Dan Ubahsuai Ruang Dalaman untuk Jabatan Sistem Maklumat Dan Jabatan Perlesenan Dan Pembersihan Di Tingkat 3 Serta Kerja-Kerja Yang Berkaitan Di Wisma Perbandaran Seremban Bandar Seremban, Negeri Sembilan Secara Sub Dari Dwi Juara Sdn Bhd'. (RM 1,452,838.20)*
14. *'Rancangan Tebatan Banjir Pekan Kota – Cadangan Membina Dan Menyiapkan Secara 'Pipe Jacking 2.4m Diameter Twin Pipe Culvert' Dan Lain-Lain Kerja Berkaitan, Daerah Rembau, Negeri Sembilan Darul Khusus'. (RM 850,000.00)*
15. *'Projek Pemasangan Railing Berhias Dan Landskap Di Kawasan 'Hotspot' Untuk Program Bandar Selamat – NKRA Pengurangan Jenayah Kawasan Kuchai Lama, Kuala Lumpur'. (RM 721,650.00)*

16. *'Kerja-Kerja Pembaikkan Semula 3 Tangki 'Sludge Hydraulic Scrapper' Dan Kerja-Kerja Berkaitan di Loji Rawatan Air Kuala Jelai, Jempol, Negeri Sembilan Darul Khusus'.* (RM 102,800.00)
17. *'Cadangan "Pocket Park" Di Jalan Silang Kuala Lumpur.* (RM 700,000.00)
18. *'Proposed Slope Rehabilitation Sg Linggi Riverbank For Kuala Sawah Trunk Sewer, Daerah Seremban, Negeri Sembilan Darul Khusus'.* (728,790.00)

2.4.2 On-going Projects

1. *'Cadangan Pembinaan Bangunan Tambahan Satu Tingkat Dan Ubahsuai Ke Atas Bangunan Dua Tingkat Pejabat Agama Islam Daerah Rembau Sediada Di Atas Lot 174, Bandar Rembau, Negeri Sembilan Darul Khusus Untuk Jabatan Hal Ehwal Agama Islam Negeri Sembilan (JHEAINS)'.* (RM 975,715.75)
2. *'Cadangan Pembangunan Seminar Za'ba Dan Lain-Lain Kerja Yang Berkaitan Di Atas PT 3323, Kampung Bukit Kerdas, Batu Kikir, Jempol, Negeri Sembilan Darul Khusus, Untuk Lembaga Muzium Negeri Sembilan'.* (RM 1,379,820.00)
3. *'Cadangan Tambahan Dan Ubahsuai Pejabat Syarikat Air Negeri Sembilan Sdn Bhd. (SAINS), Daerah Tampin, Negeri Sembilan Darul Khusus'.* (RM 625,79.89)

CHAPTER 3

MECHANICAL AND ELECTRICAL INSTALLATION

3.1 Introduction

Mechanical and electrical are included as an important aspect in constructing a building. They are needed as they facilitate people inside the building. M&E help in producing comfort, effective works and ensure the health of the occupant. M&E is quite a wide topic with many works, such as the installation of air conditioning, firefighting, and lighting which also includes the compound lightings of the whole building.

3.2 Project Background

The project is '*Cadangan Tambahan Dan Ubahsuai Pejabat Syarikat Air Negeri Sembilan Sdn Bhd. (SAINS), Daerah Tampin, Negeri Sembilan Darul Khusus*'.

This project is constructed at '*Pekan Tampin Tengah, Daerah Tampin, Negeri Sembilan Darul Khusus Untuk Tetuan Syarikat Air Negeri Sembilan Darul Khusus*'. The exact amount for this construction is RM625, 579.89 while the contract period given is 8 months which started from 4th April 2012 until 12th December 2012. However, because of weathering problem that cannot be resist, the extension of time (E.O.T.) has been requested, and the period has been longer until 16th March 2013. An amount of Liquidated Ascertain Damage (LAD) will have to be paid if there are any. So, NS Bina is working hard and doing their best to finish the construction before the end date.

In every construction, there must have varied associations or persons responsible for every aspect. For this SAINS Office construction, the related associations are Arkitek Norman Selamat as the architect and the quantity surveyor, Perunding Setia SAR as the Civil and Structure Consult (C&S) while the Mechanical and Electrical consult (M&E) is KR Associates.

3.3 Case Study

On the earliest time going there, the mechanical and electrical installation works have just started. The other works that were in progress are wall plastering and tiling in both toilets and pantry. This means, I still have advantages to learn and know better the works of both electrical and mechanical installation.

3.3.1 Installation of electrical supply

Electricity flows when there is a complete circuit. The main electrical supply is generated from '*Tenaga Nasional Berhad*' (TNB). Here, 415 Volt 3 phase supply is used to run heavy duty electrical appliances such as air conditioners. It is supplied through the GI ducts that bring in the power cable inside it. A power cable is an assembly of two or more electrical conductors, usually held together with an overall sheath. Cables consist of three major components: conductors, insulation, and protective jacket. The assembly is used for transmission of electrical power. Power cables may be installed as permanent wiring within buildings, buried in the ground, run overhead, or exposed.

Before burying the ducts, soil is excavated along the GI duct pathway. An excavator is used in excavating works according to the required or suitable depth. When laying the ducts, the power cables are also inserted inside them. The cables inside are then connected to the meter box which is located at the external wall of the building.



Diagram 3.1 : Excavating work for G.I. duct installation



Diagram 3.1 : G.I. ducts laid inside the excavated soil



Diagram 3.1 : The cross section view of a power cable



Diagram 3.1 : The electrical meter box

After that, the electrical cables are connected to the Main Distribution Board (MDB) inside the building. All electrical wires are brought in through trunkings. These trunkings are completely exposed except a certain areas that cannot be seen such as when it is located on the ceiling and under the slab. The MDB used is the low voltage-type; 0.600 kilowatt with no ampere limits and is located at the 'Ruang Taklimat' wall. This is resulted because of this building is consist of one floor only. Besides that, there are few items aside the distribution board; distribution board for lighting (DBL) and for switches (DBS).

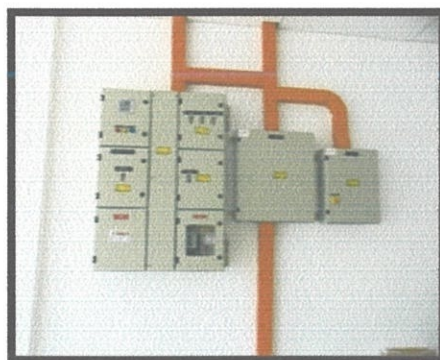

Diagram 3.1 : The main distribution board located inside the building

3.3.2 Distribution Board

A distribution board is a component of an electricity supply system which divides an electrical power feed into subsidiary circuits, while providing a protective fuse or circuit breaker for each circuit, in a common enclosure. Normally, a main switch, and in recent boards, one or more Residual-current devices (RCD) OR Residual Current Breakers with Overcurrent protection (RCBO), will also be incorporated. The DB contains bus bar, neutral link, earth bar, din rail, MCCB, RCCB, and MCB. The bus bars are large flat conductors which are used to carry three phase electricity in the distribution system. To prevent electrocution, bus bars are housed in trunking. In some bus bar systems, they are given a minimal covering of insulation, so that it can serve protection from electrocution. Other than that, miniature current breaker (MCB) acted the same way as MCCB, but it is more for smaller rating. It is also durable and it is not affected by surrounding temperature.

The MCCB is an automatically operated electrical switch designed to protect an electrical circuit from damage caused by overload or short circuit. Its basic function is to detect a fault condition and, by interrupting continuity, to immediately continue electrical flow. Unlike a fuse, which operates once and then must be replaced, a circuit breaker can reset either manually or automatically to resume normal operation. The circuit breaker in varying sizes, small-individual household appliance up to large switchgear designed to protect high voltage circuits feeding an entire city.



Diagram 3.2 : Molded circuit current breaker

The RCCB is an electrical wiring device that disconnects a circuit whenever it detects that the electric current is not balanced between the energized conductor and the return neutral conductor. RCCBs are designed to disconnect quickly enough to prevent injury to people caused by shocks. They are not intended to provide protection against overcurrent (overload) or short-circuit conditions. RCCBs with overload protection (RCBO) combine the functions of overcurrent protection and leakage detection.



Diagram 3.2 : Residual Circuit Current Breaker

3.3.3 Lighting Installation

Different types of lighting are used to suit their functions, compatibility with the ceiling types and also the aesthetic value. In this building, 32 numbers of 2 x 36 fluorescent fitting c/w aluminum parabolic louvers and mirror reflector are used. They are installed with suspended ceiling. Then, for plastered ceiling, 23 numbers of 2 x 26 PLC down light c/w reflector are used. For 1 x 36 fluorescent fitting (bare channel), they are installed in both female and male toilets, while 2 numbers of fluorescent fitting c/w Daikon diffuser (surface mounted) are used at the car porch. Different lighting is for different uses and it is need to suits different situations and areas.

A recessed light or down light is a light fixture that is installed into a hollow opening in a ceiling. When installed it appears to have light shining from a hole in the ceiling, concentrating the light in a downward direction as a broad floodlight or narrow spotlight.



Diagram 3.3 : fluorescent fitting c/w aluminum parabolic louvers and mirror reflector

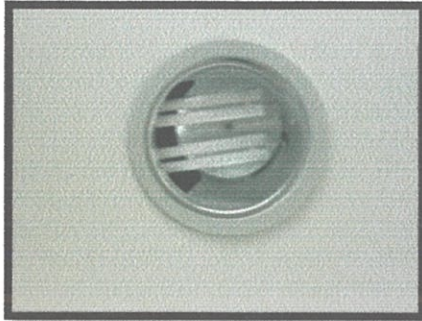

Diagram 3.3 : PLC down light c/w reflector



Diagram 3.3 : Fluorescent fitting c/w Daikon diffuser

3.3.4 Emergency Lighting

An emergency light is a battery-backed lighting device that comes on automatically when a building experiences a power outage. When the normal supply of AC power fails, the emergency lighting senses the power failure and immediately switches to the emergency mode, illuminating the emergency light for a minimum of 3 hours. During emergency lighting output is evenly divided for better distribution of emergency illumination. When AC power is restored, the emergency light returns to the charging mode until the next power failure. The sealed nickel cadmium battery fully recharges within 24 hours. (Catalog B.B LITE by Nicron Industries Sdn Bhd)

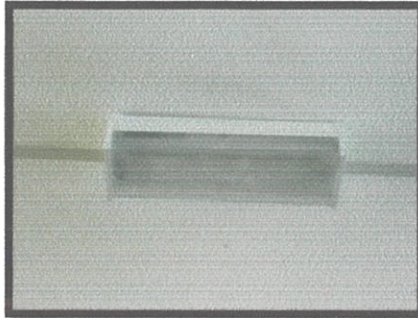

Diagram 3.4 : Emergency lighting

3.3.5 Galvanized Steel 'EXIT' Sign

An exit sign is a device in a public facility denoting the location of the closest emergency exit in case of fire or other emergency. LED light is used for this application as LED light sources produce no heat, because its fixture consume fewer watts than incandescent lamps and it sources last 100,000 hours or more without failure. To application used both electrical and batter-back up. When there is failure on electricity supply, it will automatically use the backup battery, and the opposite way when the electrical supply is there.



Diagram 3.5 : Galvanized steel 'EXIT' sign

3.3.6 Air-conditioning Installation

Air-conditioner is used to change the air temperature and humidity within an area. Here, they used the unitary split system air-conditioner which can be divided to two more categories. They are, package unit and unventilated split system.

i. Package unit

This type is used for chilling one or few small spaces within a same time. All equipment is placed outside of the building near to the area to be cooled. The distribution of air in the room is via air supply duct and air return duct. The heat is released through the fan from side or top unit.



Diagram 3.6 : Package unit air conditioner

ii. Unventilated split system

This is used in chilling one to three spaces or small rooms which can be handled separately. The unit contains two main components, which are condensation unit and evaporation unit. The condensation unit is located outside the building, while the evaporation unit is located inside. Both of these are connected through insulated cooling circulation pipe. Most of their main components; compressor, evaporator and expansion valve are located inside the outer unit.



Diagram 3.6 : Unventilated split air-conditioner (evaporation unit)

3.3.7 Split system Installation

1. Installation of indoor unit

- i. First, select a location on interior wall to mount the indoor air conditioning unit. It is important to avoid direct sunlight and heat resources and locations where gas may leak. The indoor unit requires at least 6" of open space surrounding its top and sides and it should also be mounted at least 7 feet above the ground. In supporting the unit, metal frame support can be used.
- ii. After that, secure the mounting plate to the interior wall. Hold the mounting plate against the wall where the unit needs to be installed. Then, drill holes into the wall to affix the plate to the wall and insert plastic anchors into the holes and secure the plate with tapping screws.

- iii. Next create a hole in the wall to fit the piping. Find a spot for the hole to the exterior based on the opening in the mounting bracket. Drill a hole through the wall but make sure the hole slope **downward toward the exterior** to ensure good drainage.
- iv. Then, check the electrical connections. Lift the unit's front panel and remove the cover. Make sure the cable wires are connected to the screw terminals.
- v. Connects the pipe and run it from the indoor unit toward the drilled hole through the wall. Cut a PVC pipe (6 mm) shorter than the length between the interior and exterior wall surfaces. Place the pipe cap on the interior end of the PVC pipe. Insert the pipe into the hole in the wall. Bind the copper pipes, power cables and the drain pipe together with electrical tape. Place the drain pipe on the bottom to ensure a free water flow and secure the pipe to the indoor unit. By using wrenches, tighten the connection. Join the water drainage pipe to the indoor unit's base and run the bound pipes and cables through the hole in the wall.

2. Installation of Outdoor Condenser

- i. The outdoor unit's location needs to be away from any heavily trafficked, dusty or hot areas. The outdoor unit needs about 12" of space surrounding it to ensure proper functioning.
- ii. Then, connect the electrical wires and remove the cover. Fasten the cables with a cable clamp and replace the cover. Next, secure the pipes' flare nuts to the corresponding pipes on the outdoor unit.

3. Complete the split system air conditioner installation

- i. Bleed the air and humidity from the refrigerant circuit. Remove the caps from the 2-way and 3-ways valves and from the service port. Then, connect a vacuum pump hose to the service port. Turn the vacuum on until it reaches an absolute vacuum of 10mm Hg. Close the low pressure knob and then turn off the vacuum. Test all of the valves and joints for leaks. Disconnect the vacuum, replace the service port and caps.
- ii. After that, wrap the joints of the piping with insulating covering and insulating tape. Affix the piping to the wall with clamps and seal up the hole in the wall using expanding polyurethane foam.



Diagram 3.7 : Air conditioner installation work

3.3.8 Installation of communicating and internet supply

Communication is the activity of conveying information through the exchange of thoughts, messages, or information, as by speech, visuals, signals, writing, or behavior. The internet is needed at the working and counter areas. There are internet and communication modems in the server room, and from there, the internet and communication wires are distributed to every workstation. They are laid through trunkings and PVC pipes and distributed at every junction box, which then rise from the floor level to the workstation. The same procedures are applied at the counter area. The grey wires represent communicating supply, while blue is for internet.

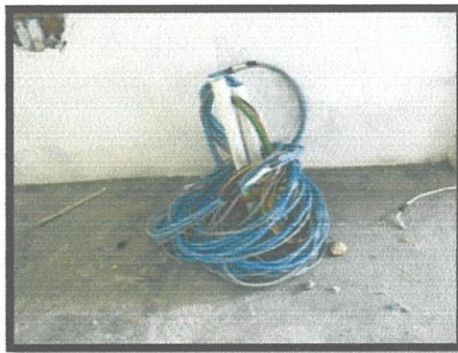

Diagram 3.8 : The communicating & internet wires

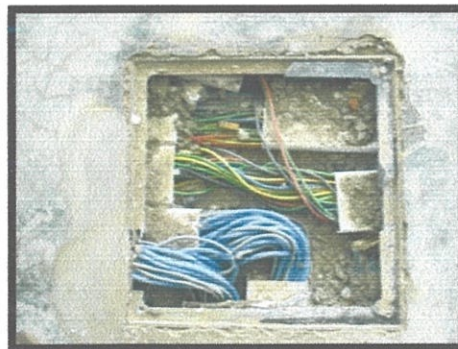

Diagram 3.8 : The wires distribution in electrical junction box

3.3.9 Fiber optic

It is a flexible, transparent fiber made of glass (silica), or plastic. It functions as a waveguide or light pipe to transmit light between the two ends of the fiber. Fiber is used instead of metal wires because signals travel along them with less loss and are also immune to electromagnetic interference.

The fiber optic consists of a few parts, which are core, cladding and buffer coating. Core is a thin glass center of the fiber where the light travels, while cladding is an outer optical material surrounding the core that reflects the light back into the core. Lastly, buffer coating is a plastic coating that protects the fiber from damage and moisture.

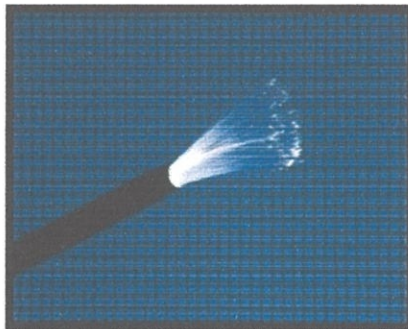

Diagram 3.9 : Fiber optic

3.3.10 Access Control Door System

Access control is a process where the movement of a person whether in or out of a building is controlled through doors, lifts and gates for various security reasons. Access control system is vital in places which require high security. Airports, hospitals, military installation, prisons are some places where access control systems are necessary.

There are 4 types of this system that are available. They are keypad reader, card reader system, proximity card reader and magnetic swipe card.

1. Keypad Reader

This device allows access into a premise by pressing or entering the correct pin number. The system permits entry with the release of an electromagnetic lock. If an incorrect pin is entered, access will be denied.



Diagram 3.10 : Example of keypad reader access controller

2. Card Reader System

The card is usually made of laminated plastic or paper. An encoding media is embedded in the card and is encoded with the identification number and related information. Some of the encoding media can be recorded and erased repeatedly thus allowing a card to be used for other doors and individuals. It also allows the card to store access records of the particular door. These are some examples of the card reader access control door :

i. Proximity Card Reader

The security system allows entry by presenting the proximity card to it. The electromagnetic lock releases. An invalid card will be rejected at the entry.

ii. Magnetic Card Reader

This card consists of a magnetic strip where the access information of the person is stored for security purpose. It does not provide a high degree of security because it is fairly easy to counterfeit both card and the encoded identification code. However, they are cheap and less affected by stray magnetic fields than barium ferrite card.

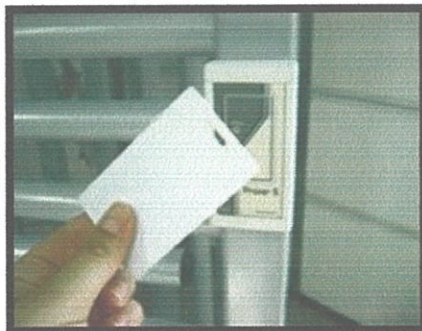

Diagram 3.10 : Proximity card reader access door

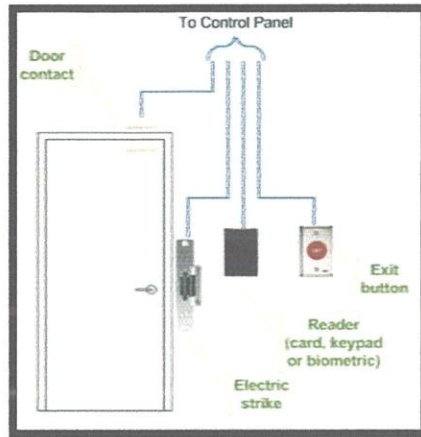

Diagram 3.11 : Example of access control door wiring

3.3.12 CCTV Installation

CCTV or Closed-Circuit Television Surveillance Systems consists of one or more television cameras connected by coaxial cable to video monitors and a video recorder. The advantage of this system is ability to record the intruder or crime and thus enable the identification of the intruder or criminal. CCTV is used to provide security when the use of physical and electronic security systems is not feasible.

2 numbers of charged coupled device (CCD) cameras are located at the counter area and waiting area. They are positioned there as there will be many unknown people come in to do business. These CCDs are popular because they are light, smaller, have low maintenance and operating costs and can operate satisfactory at lower light levels (1.5 to 0.07 lux). But, they have a relatively low picture resolution.

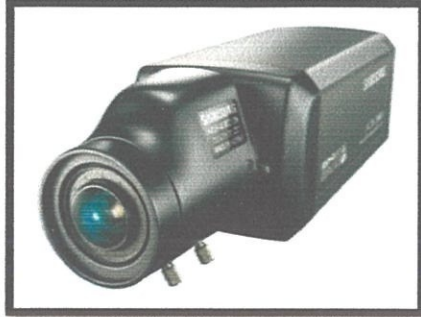

Diagram 3.12 : Charged coupled device camera

The television monitor for the CCTV system are specially designed to have higher resolutions and for 24-hour use. Thus, normal televisions are not suitable for this purpose. The monitor is seldom designed to be able to receive normal television broadcasts. To install the CCTV system, first, crimp each RG59 line ends with Bayonet Neill-Concelman (BNC) connectors, then connect them to Digital Video Recorder. The camera requires direct current (DC) voltage for their supply. Before turning on the power supply, make sure the DVR is connected to the monitor.

3.3.13 Fire Fighting Installation

Firefighting equipment installation is very important in securing the safety of the occupants, properties and also the building itself. The firefighting system that is applied to the building is active fire protection. Active fire protection is an integral part of fire protection. It is characterized by items or systems, which require a certain amount of motion and response in order to work.

A number of photoelectric smoke detector is located at the Server and CCTV Room. The detector is installed by placing it to the ceiling using screw driver and screws. Fire is detected either by locating the smoke, flame or heat, and an alarm is sounded to enable emergency evacuation. The main reason of why it is placed in there is because the percentage of fire to trigger is higher compared to other rooms. The server room consists of various wires that can be the main factor of accident. So, when detector is applied, it is easy to detect early growth of fire that occurs.

Besides that, it must be served with fire suppression. Here, 4 numbers of 9 kg dry powder ABC type extinguishers and a number of 2.2 kg carbon dioxide (CO₂) type extinguisher is used.



Diagram 3.13 : Dry powder ABC and CO₂ type extinguisher

The type of smoke detector used is single station photoelectric. It is designed to detect smoke that comes into the detector chamber. It does not sense gas, heat or flame. This detector is designed to give early warning of developing fires by giving off the alarm sounds from its built-in alarm horn and it can provide time for occupants to escape before a fire spreads. However, the detector makes such pre-warning of fire accident possible, only if the detector is located, installed and maintained properly as described in the User's Manual.

This model is to be mounted on the ceiling. Since this is a single-station type, it cannot be linked to other detectors. In installing the smoke detector, first, draw a six inches long horizontal line. Then, remove the mounting bracket from the unit by rotating it counter clockwise. Place the bracket so that the longest hole slots are aligned on the line. In each of keyhole slots, draw a mark to locate a mounting plug and screw.

After that, remove the bracket. Next, using a 3/16-inch (5mm) drill bit, drills two holes at the marks, and inserts plastic wall plugs. Using two screws and plastic wall plugs, attach the bracket to the wall.



Diagram 3.13 : Photoelectric Smoke Detector

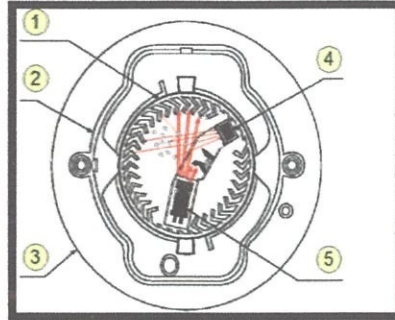

Diagram 3.13 : Cross section of smoke detector

- 1- Optical chamber
- 2- Cover
- 3- Case molding

- 4- Photo diode
- 5- Infra-red LED

CONCLUSION AND SUGGESTIONS

Electrical and Mechanical installation in construction projects is important in ensuring the efficiency and compatibility of occupant inside. Its quality also directly affects the safe operation of the equipment in the building, energy efficiency and the use of the building.

So, every person or occupants inside the building need to assure and take care of the condition of the M&E system as long term problems probably occur.

REFERENCES

1- Internet

- i- Sturgeon, W., 1825, Improved Electro Magnetic Apparatus, *Trans. Royal Society of Arts, Manufactures, & Commerce* (London) 43: pp. 37–52, as cited in Miller, T.J.E, 2001, *Electronic Control of Switched Reluctance Machines*, Newnes, p. 7. ISBN 0-7506-5073-7

- ii- Tryme2, BR, Chloe () How to install a split system air conditioner, retrieved from www.wikihow.com/Install-a-Split-System-Air-Conditioner

2- Books

- i- Semester 3 Building Services Note Book



- 3D PERSPEKTIF -

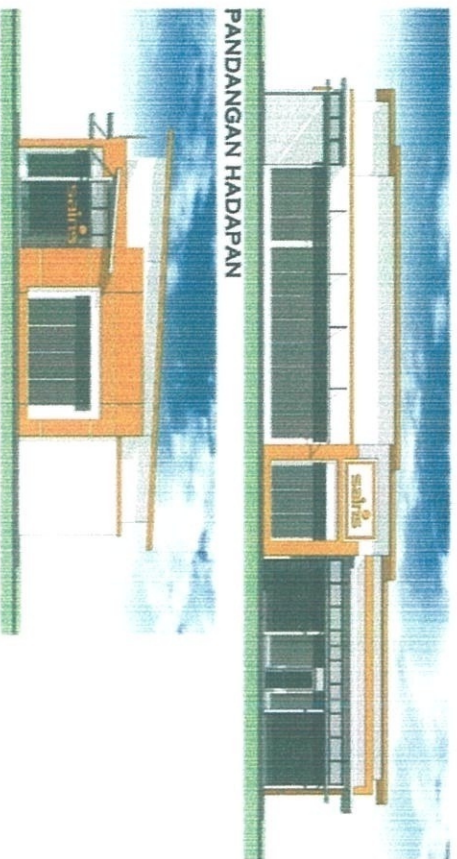

PANDANGAN HADAPAN



PANDANGAN SISI

CADANGAN MEMBINA PEJABAT PENTADBIRAN DAN OPERASI SAINS DAERAH





SYARIKAT AIR NEGERI SEMBILAN SDN. BHD.

LAPORAN BULANAN # 6

BERAKHIR 31 JANUARI 2013

**CADANGAN TAMBAHAN DAN UBAHSUAI PEJABAT SYARIKAT AIR
NEGERI SEMBILAN SDN.BHD.(SAINS), DAERAH TAMPIN,
NEGERI SEMBILAN DARUL KHUSUS**

DISEDIAKAN OLEH :

**NS BINA
NO. 6061-1,JALAN SJ 5/1
TAMAN SEREMBAN JAYA
70450 SEREMBAN,
NSDK**

FAX : 06-678 8381

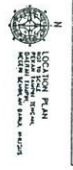
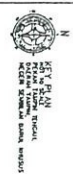
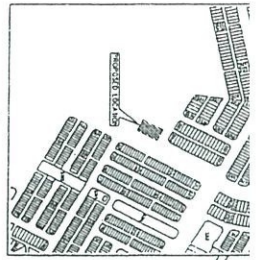
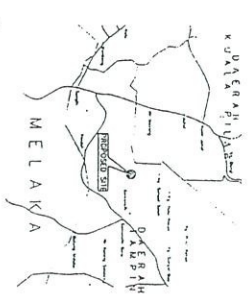

LEGEND

	PROPOSED 11kV 119V SON COMPOUND LIGHTING AT 6m CANVASSED POLE (BARE UNDERDRUM)
	100mm CL. PFC FOR CROSSING ROAD
	7M SW SOLUTION FOR TOWER SPACED

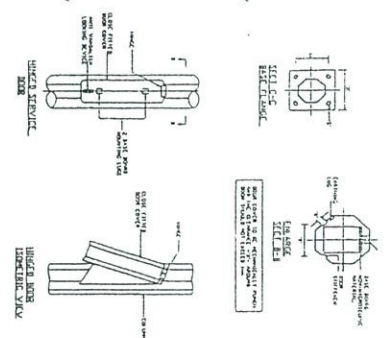
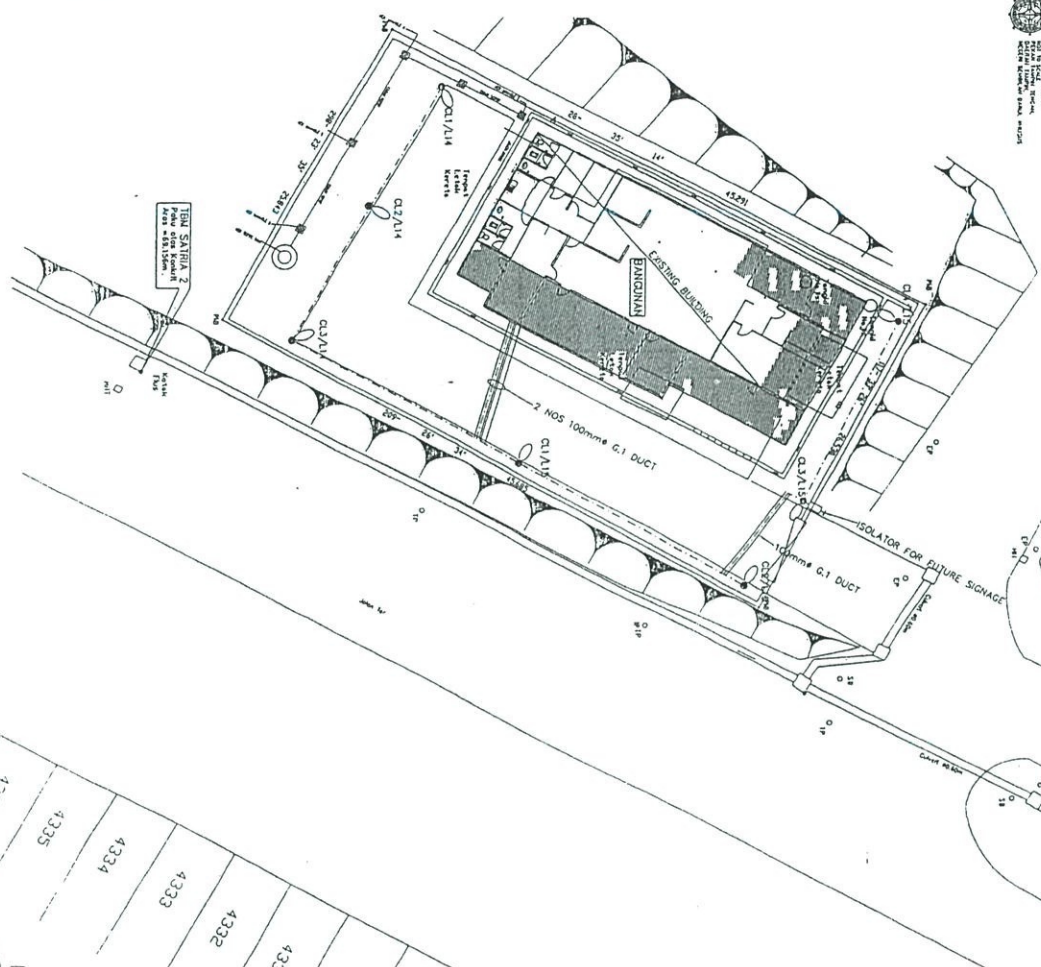
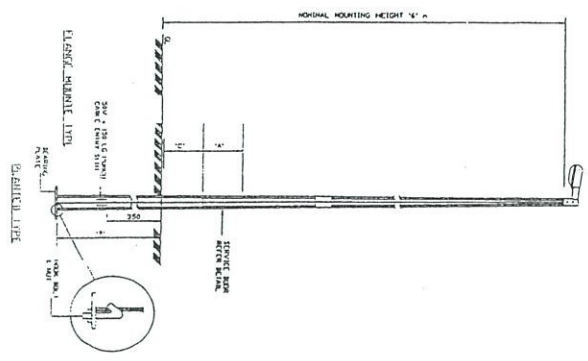

SITE PLAN
 SCALE: 1:200
 PEKAN TAJAN TENGAH
 HECEC SEMUNJUT BANGLOK
 PROPOSED EYEVISION AREA

TENDER DRAWING

<input type="checkbox"/> PROVISION	<input type="checkbox"/> SCHEDULE	<input type="checkbox"/> CONTRACT
<input type="checkbox"/> PROVISION	<input type="checkbox"/> SCHEDULE	<input type="checkbox"/> CONTRACT

No	Revisi	Revisi

PROJEK: PROJEK TAJAN TENGAH DAN UBAHAN PE
 SYABANT AIR NEGARA (SAINS) DAERAH TAJAN
 NEGERI SEMBILAN DARUL KHAUSIS

UNITUK TEJUK SYABANT AIR NEGARA SEMBILAN

PELUK TAJAN :

PENCORNA

AMPS
 AMPLIFIED POWER SUPPLY SYSTEMS
 100, Jalan Sultan Ismail, 40100 Shah Alam, Selangor, Malaysia
 Tel: +603-51011111 / 51011112 / 51011113 / 51011114 / 51011115 / 51011116 / 51011117 / 51011118 / 51011119 / 51011120 / 51011121 / 51011122 / 51011123 / 51011124 / 51011125 / 51011126 / 51011127 / 51011128 / 51011129 / 51011130 / 51011131 / 51011132 / 51011133 / 51011134 / 51011135 / 51011136 / 51011137 / 51011138 / 51011139 / 51011140 / 51011141 / 51011142 / 51011143 / 51011144 / 51011145 / 51011146 / 51011147 / 51011148 / 51011149 / 51011150 / 51011151 / 51011152 / 51011153 / 51011154 / 51011155 / 51011156 / 51011157 / 51011158 / 51011159 / 51011160 / 51011161 / 51011162 / 51011163 / 51011164 / 51011165 / 51011166 / 51011167 / 51011168 / 51011169 / 51011170 / 51011171 / 51011172 / 51011173 / 51011174 / 51011175 / 51011176 / 51011177 / 51011178 / 51011179 / 51011180 / 51011181 / 51011182 / 51011183 / 51011184 / 51011185 / 51011186 / 51011187 / 51011188 / 51011189 / 51011190 / 51011191 / 51011192 / 51011193 / 51011194 / 51011195 / 51011196 / 51011197 / 51011198 / 51011199 / 51011200

JURUTERA ELEKTRIKAL
 DR. MOHD ZAKIR YAZD
 9418
 MALAYSIA

JURUTERA MEKANIKA & ELEKTRIKAL

KR ASSOCIATES
 NO. 28, TINGKAT ATAS,
 75000 SEMBILAN NEGERI SEMBILAN,
 MALAYSIA
 Tel: +603-70811111 / 70811112 / 70811113 / 70811114 / 70811115 / 70811116 / 70811117 / 70811118 / 70811119 / 70811120 / 70811121 / 70811122 / 70811123 / 70811124 / 70811125 / 70811126 / 70811127 / 70811128 / 70811129 / 70811130 / 70811131 / 70811132 / 70811133 / 70811134 / 70811135 / 70811136 / 70811137 / 70811138 / 70811139 / 70811140 / 70811141 / 70811142 / 70811143 / 70811144 / 70811145 / 70811146 / 70811147 / 70811148 / 70811149 / 70811150 / 70811151 / 70811152 / 70811153 / 70811154 / 70811155 / 70811156 / 70811157 / 70811158 / 70811159 / 70811160 / 70811161 / 70811162 / 70811163 / 70811164 / 70811165 / 70811166 / 70811167 / 70811168 / 70811169 / 70811170 / 70811171 / 70811172 / 70811173 / 70811174 / 70811175 / 70811176 / 70811177 / 70811178 / 70811179 / 70811180 / 70811181 / 70811182 / 70811183 / 70811184 / 70811185 / 70811186 / 70811187 / 70811188 / 70811189 / 70811190 / 70811191 / 70811192 / 70811193 / 70811194 / 70811195 / 70811196 / 70811197 / 70811198 / 70811199 / 70811200

PEK TAJAN

TENDER DRAWING

No	Terbilang	Persediaan

CADANGAN TAWARAN DAN UBAHIAN PEJABAT (KEMAS) TARIK NEGARA SEMBILAN (SMN) BID'AN NEGERI SEMBILAN DIKUALIFIKASI KURSUS
 UNITAK TERBUKA
 SYARIAH KAN' NEGARA SEMBILAN
 PEJABAT SYARIAH :

ITEM	DESCRIPTION	UNIT	QTY	PRICE	TOTAL
1	1.1 x 1.1 x 1.1	1	1	1	1
2	1.1 x 1.1 x 1.1	1	1	1	1
3	1.1 x 1.1 x 1.1	1	1	1	1
4	1.1 x 1.1 x 1.1	1	1	1	1
5	1.1 x 1.1 x 1.1	1	1	1	1

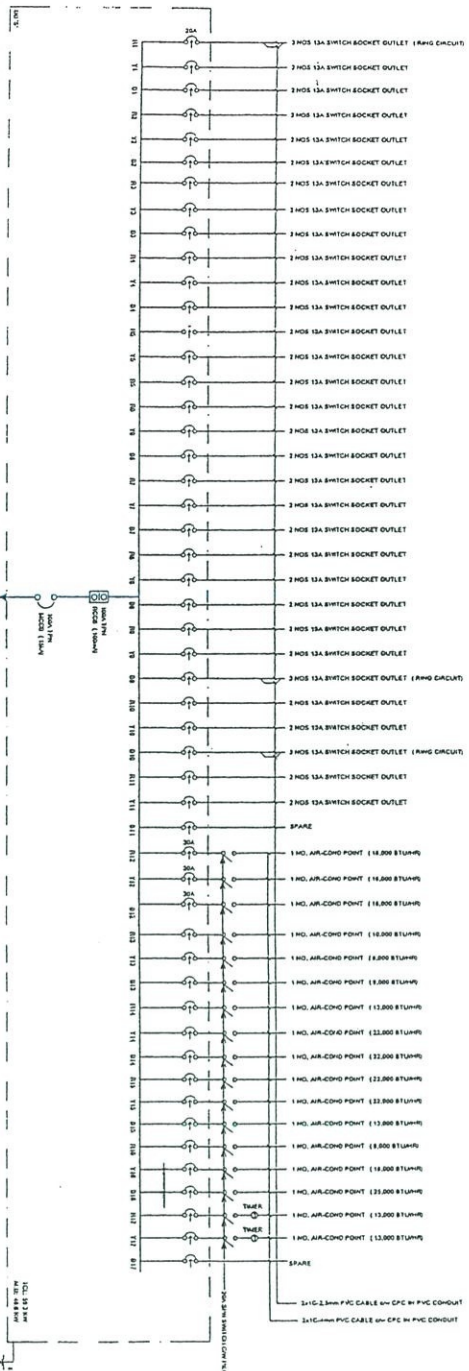

SCHEMATIC DIAGRAM FOR (DB-S)

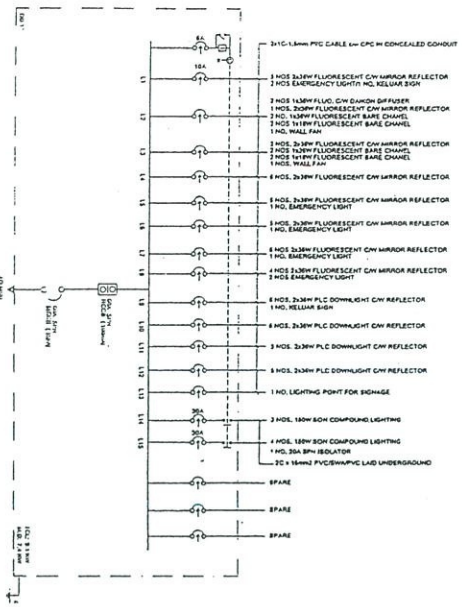

SCHEMATIC DIAGRAM FOR (DB-L)

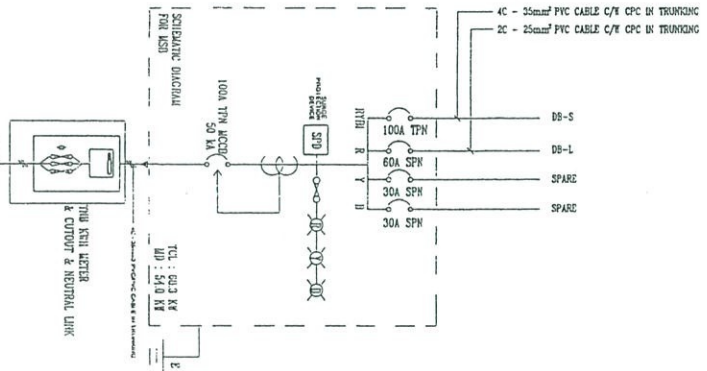

SCHEMATIC DIAGRAM FOR (MS)

- 1. ALL ESTIMATE, QUANTITY, UNIT, UNIT IN SQUARE AND CUBIC METERS.
- 2. ALL QUANTITY, QUANTITY, UNIT, UNIT IN SQUARE AND CUBIC METERS.
- 3. ALL QUANTITY, QUANTITY, UNIT, UNIT IN SQUARE AND CUBIC METERS.
- 4. ALL QUANTITY, QUANTITY, UNIT, UNIT IN SQUARE AND CUBIC METERS.
- 5. ALL QUANTITY, QUANTITY, UNIT, UNIT IN SQUARE AND CUBIC METERS.
- 6. ALL QUANTITY, QUANTITY, UNIT, UNIT IN SQUARE AND CUBIC METERS.
- 7. ALL QUANTITY, QUANTITY, UNIT, UNIT IN SQUARE AND CUBIC METERS.
- 8. ALL QUANTITY, QUANTITY, UNIT, UNIT IN SQUARE AND CUBIC METERS.
- 9. ALL QUANTITY, QUANTITY, UNIT, UNIT IN SQUARE AND CUBIC METERS.
- 10. ALL QUANTITY, QUANTITY, UNIT, UNIT IN SQUARE AND CUBIC METERS.

KR ASSOCIATES
 20, JALAN PERAK 27, KAMPUNG BERSEKUTAN, JAJARAN BANGSA, KUALA LUMPUR.
 TEL: 03-2092-1111
 FAX: 03-2092-1112
 E-MAIL: info@krassociates.com

JURUTERA MEKANIKA & ELEKTRIKAL
 NO 148/5041

JURUTERA MEKANIKA & ELEKTRIKAL
 NO 148/5041

AMTEK
 100, JALAN PERAK 27, KAMPUNG BERSEKUTAN, JAJARAN BANGSA, KUALA LUMPUR.
 TEL: 03-2092-1111
 FAX: 03-2092-1112
 E-MAIL: info@amtek.com

JURUTERA MEKANIKA & ELEKTRIKAL
 NO 148/5041

AMTEK
 100, JALAN PERAK 27, KAMPUNG BERSEKUTAN, JAJARAN BANGSA, KUALA LUMPUR.
 TEL: 03-2092-1111
 FAX: 03-2092-1112
 E-MAIL: info@amtek.com

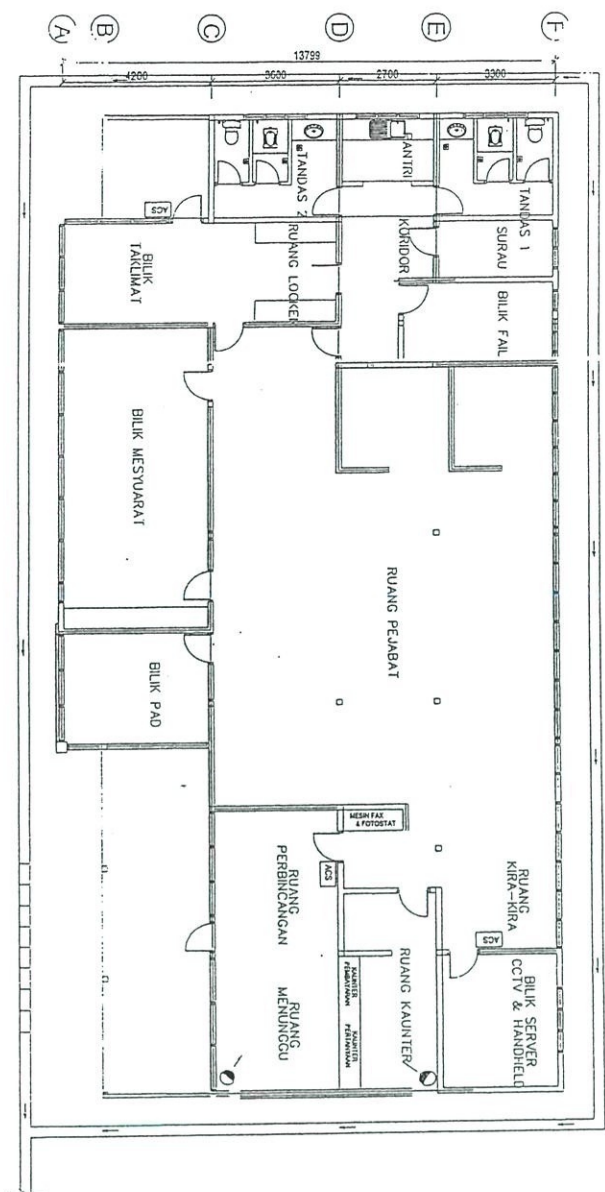
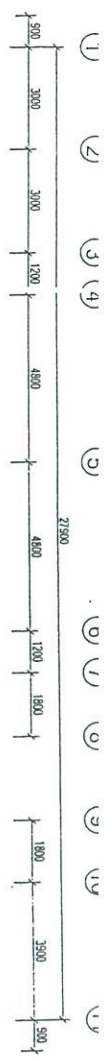

GROUND FLOOR PLAN
SCALE 1 : 100

KAUNTER PEMBAYARAN
RUANG MENUNGGU
2 NOS INDOOR CAMERA

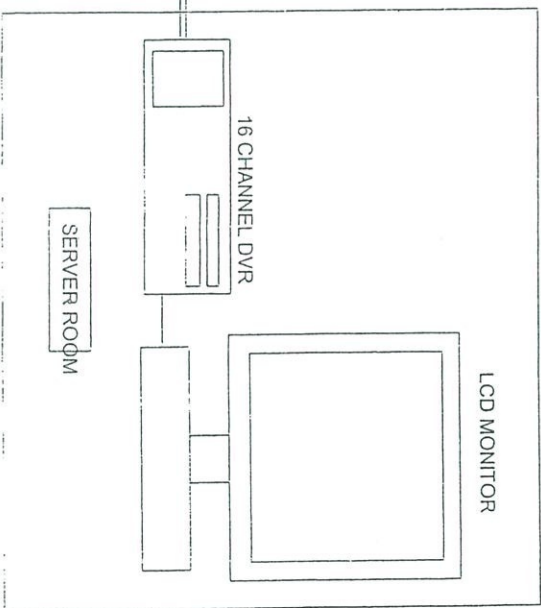

Proj. 1
CUBIC CIRCUIT TELEVISION

TENDER DRAWING

No. Tahan: Pundun

PROJEK TAMBAHAN DAN UBAHAN PEJAJA
PEJAJA MELAKA
(SARIS) DAERAH TAMPILAN SEMI BHD
NEGERI SEMPURAN DANUL KURUSUS.

UNITIK TEJUNG
SYARIKAT AIR NEGERI SEMPURAN
PEMULUK TAMAYI :

PENGODJAN

AMK PERKOR SD/DAULAT



TAMBAHAN JARITERA

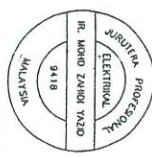

JARITERA MEKANIKAL & ELEKTRIKAL

KR ASSOCIATES
KORPORAT TEKNOLOGI
TAMBAHAN JARITERA
MEKANIKAL & ELEKTRIKAL
NO. 23, JALAN HATI MUDA
KAMPUNG BANGSI BANGSIN, SEREMBAN
NEGERI SEMBILAN
70000 SEREMBAN
70000 SEREMBAN
TELE: 06-73584821
FAX: 06-73584822
EMAIL: kr_electrical@krassoc.com
www.krassoc.com

DI LUAS : ABRU SKALA : 1:75
DI SIKAM : KER. TAMBUK : 0005 2011
TAJUK LURUSAN
ELECTRICAL INSTALLATION
- CITY LAYOUT
- DOOR ACCESS LAYOUT

NO LURUSAN
KR/SBN/SARIS/AE/TAMPN/E/11-(C

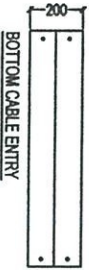
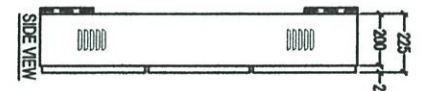
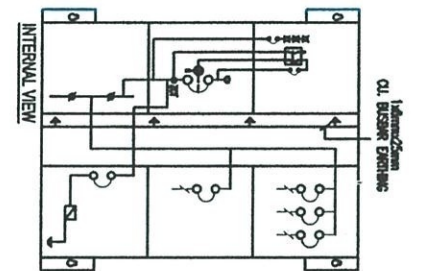
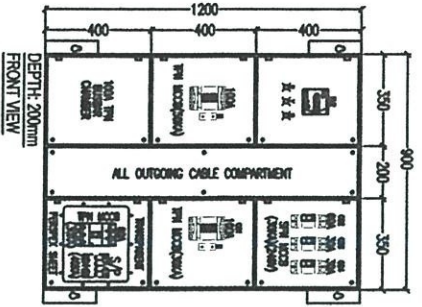
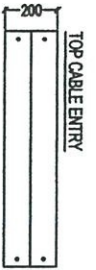

NOTE:
o) ALL LABELS FOR INCOMING & OUTGOING BREAKERS SHALL BE RIGIDLY

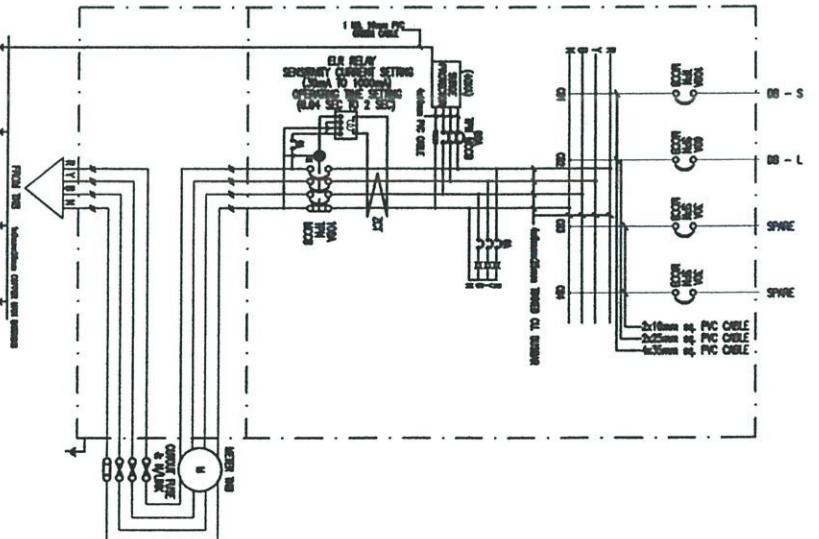
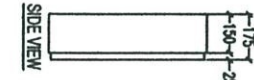
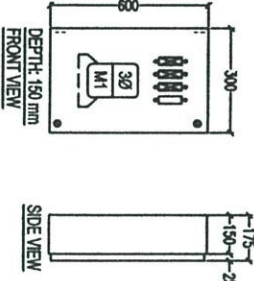

MANUFACTURER  STARLITE CADANGAN TAMBAHAN DAN UBAHAN PELAJAT SYARIKAT AIR NEGERI SEMBILAN SDN. BHD. (SAINS) DAERAH TAMPIN, NEGERI SEMBILAN DARUL KHUSUS. UNTUK TETAPAN : SYARIKAT AIR NEGERI SEMBILAN. TEL : 606-6781238 e-mail: on@starliteelectrical.com.my	PROJECT CADANGAN TAMBAHAN DAN UBAHAN PELAJAT SYARIKAT AIR NEGERI SEMBILAN SDN. BHD. (SAINS) DAERAH TAMPIN, NEGERI SEMBILAN DARUL KHUSUS. UNTUK TETAPAN : SYARIKAT AIR NEGERI SEMBILAN.	OWNER SYARIKAT AIR NEGERI SEMBILAN (SAINS) KETUA PECAWAL EKSEKUTIF TANAKI Z. KOMPERS PANGS, 70450 SEMBILAN, NEGERI SEMBILAN. NEGERI SEMBILAN DARUL KHUSUS.	MAE CONSULTANT KR ASSOCIATES, NO. 38, TINGKAT ATAS, JALAN ORKID 2, TAMAN SEMAWANG INDAH, 70450 SEMBILAN, NEGERI SEMBILAN. TEL : 006 - 6787022 EMAIL : kr_associate@gmail.com	CONTRACTOR NS BINA, NO. 006-1-1, JALAN S.J. 5/1, TAMAN SEMBILAN JAYA, 70450 SEMBILAN, NEGERI SEMBILAN DARUL KHUSUS. TEL : 006 - 6783831	TITLE GENERAL ARRANGEMENT & SCHEMATIC DIAGRAM FOR MAIN SWITCH BOARD	DESIGNED : C.T. WONG CHECKED : ALLY WONG DRAWN : ZARIF SCALE : N.T.S. DRAWING NO. : S/FCDD0666/2012 SHEET NO. : 02	DATE : 28 APRIL 2012 REV : 0
---	--	---	--	--	---	---	---

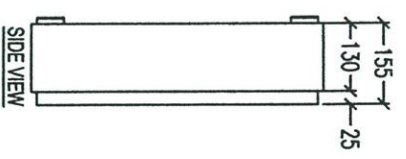
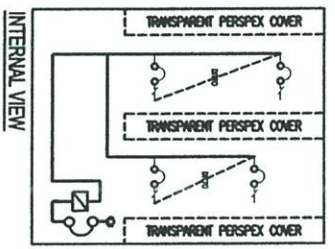
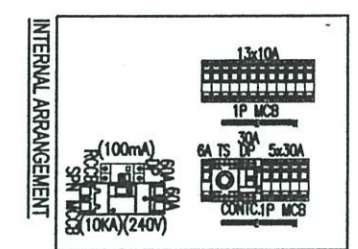
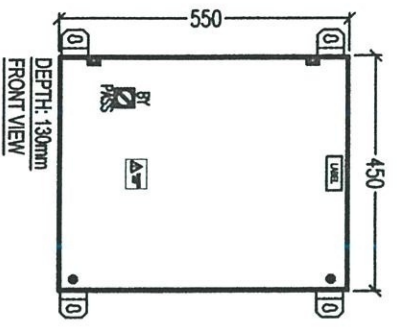

DBL
TOTAL QTY: 1 UNIT

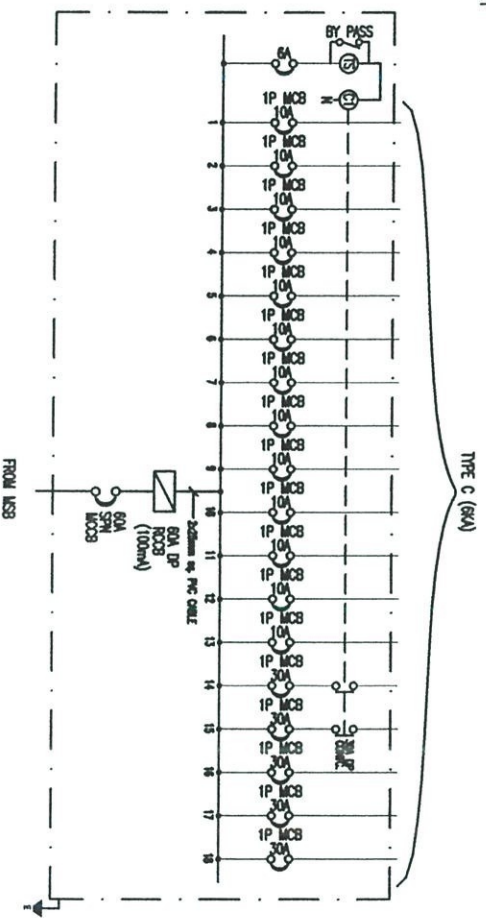

MANUFACTURER 	
PROJECT CADANGAN TAMBAHAN DAN UBAHAN PELAKSANAAN SYARikat AIR NEGERI SEMBILAN SBN, BHD (SANS) DAERAH TAMPAK NEGERI SEMBILAN DARUL KHUSUS, UNTUK TELUANG SYARikat AIR NEGERI SEMBILAN.	
OWNER SYARikat AIR NEGERI SEMBILAN (SANS) KETUA PEJAWAJ EKSEKUTIF TAMPAK NEGERI SEMBILAN SBN, BHD, 7000 SEMBILAN, NEGERI SEMBILAN DARUL KHUSUS.	
MAE CONSULTANT HR ASSOCIATES NO. 36, TINGKAT ATAS, JALAN OKRD 2, TAMAN SENAWANG INDAH, 70450 SEREMBAN, NEGERI SEMBILAN. TEL: 06-6787922 FAX: 06-6787922 EMAIL: hr_associates@mail.com	
CONTRACTOR NS BINA NO. 6051-1, JALAN SJ 5/1, TAMAN SEREMBAN JAYA, 70450 SEREMBAN, NEGERI SEMBILAN DARUL KHUSUS. TEL: 06-6788391 FAX: 06-6788391	
TITLE GENERAL ARRANGEMENT & SINGLE LINE FOR DBL	
DESIGNED : C.T. WONG	DATE : 28 APRIL 2012
CHECKED : ALLY WONG	REV : 0
DRAWN : ZAIRIF	
SCALE : N.T.S.	
DRAWING NO : SFCDD0668/2012	
SHEET NO : 03	

STARLITE
 LOT 11174, KAWASAN PERINDUSTRIAN TAMAN TUNGGU JAYA, JALAN SGI, GADUT, 70450 SEREMBAN, NEGERI SEMBILAN DARUL KHUSUS.
 TEL: 06-606-6781288
 E-mail: starlite@starliteelectrical.com.my

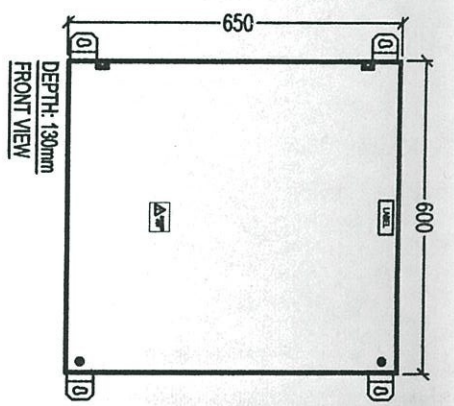

DEPTH: 130mm
FRONT VIEW
DB-S
TOTAL QTY: 1 UNIT

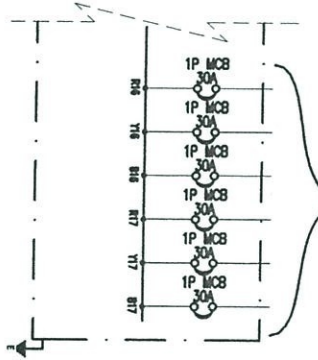
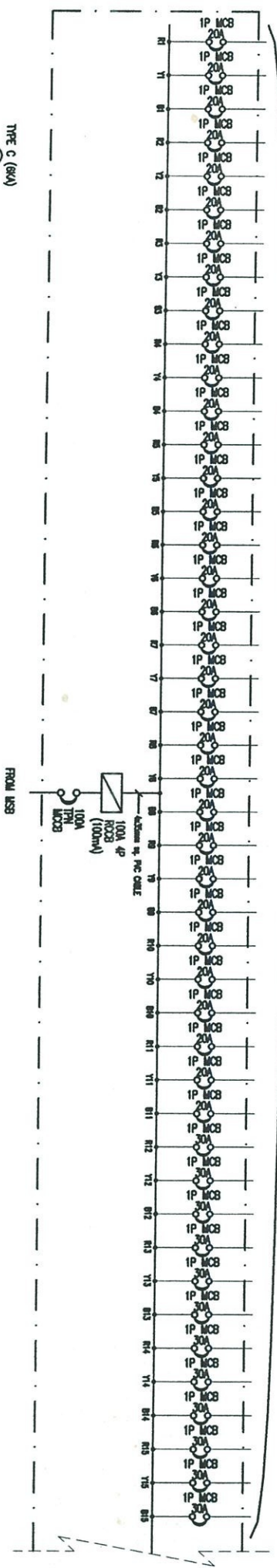
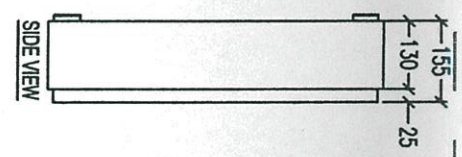
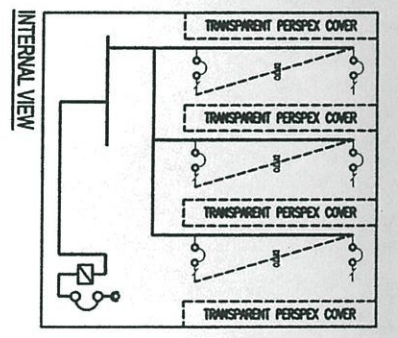
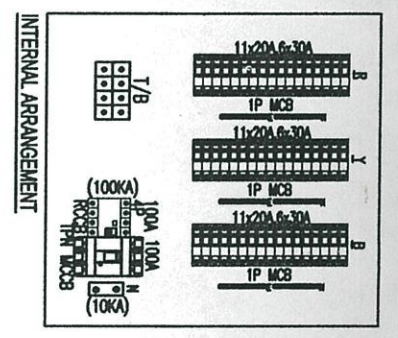

MANUFACTURER STARLITE CADANGAN TAMBAHAN DAN UBAHAN PENABAT SYARikat AIR NEGERI SEMBILAN SDN. BHD. (SANS) DABAH TAMPIN, TAMAN TUNANGKU JAYA 7K, JALAN SOS. GADUT 1, 70600 SEREMBAN, NEGERI SEMBILAN DARUL KHUSUS. TEL: 606-6781228 E-mail: eng@starliteindustrial.com.my	PROJECT CADANGAN TAMBAHAN DAN UBAHAN PENABAT SYARikat AIR NEGERI SEMBILAN SDN. BHD. (SANS) DABAH TAMPIN, TAMAN TUNANGKU JAYA 7K, JALAN SOS. GADUT 1, 70600 SEREMBAN, NEGERI SEMBILAN DARUL KHUSUS. UNITIK TETAPAN : SYARikat AIR NEGERI SEMBILAN.	OWNER SYARikat AIR NEGERI SEMBILAN (SANS) KETUA PEJAWAJ EKSEKUTIF TINGKAT 2, KOMPLEKS PONS, JALAN PERSEKAWAN 82 B2, NEGERI SEMBILAN, NEGERI SEMBILAN DARUL KHUSUS.	MAKE CONSULTANT IIR ASSOCIATES NO. 38, TINGKAT ATAS, JALAN OKROD 2, TAMAN SENAWANG INDAH, 70600 SEREMBAN, NEGERI SEMBILAN, NEGERI SEMBILAN DARUL KHUSUS. TEL: 606-6787022 FAX: 606-6787022 EMAIL: ir_associates@gmail.com	CONTRACTOR NS BINA NO. 6081-1, JALAN SJ 5/1, TAMAN SEREMBAN JAYA, NEGERI SEMBILAN, NEGERI SEMBILAN DARUL KHUSUS. TEL: 606-6788381 FAX: 606-6788381	TITLE GENERAL ARRANGEMENT & SINGLE LINE FOR DB-S	DESIGNED : C.T. WONG	DATE : 28 APRIL 2012	REV : 0
						CHECKED : ALLY WONG		
DRAWN : ZARIF								
SCALE : N.T.S.								
DRAWING NO : SFGCD/0866/2012								
SHEET NO : 04								