

Resident attitudes towards support for future tourism: Utilising the Social Exchange Theory (SET)

Journal of Tourism, Hospitality & Culinary Arts (JTHCA)
2020, Vol. 12 (3) pp 106-119
© The Author(s) 2020
Reprints and permission:
UITM Press
Submit date: 15th November 2020
Accept date: 04th December 2020
Publish date: 28th December 2020

Irfana Rashid

Department of Management Studies
University of Kashmir, INDIA
babairfana@gmail.com

Proposed citation:

Rashid, I. (2020). Resident Attitudes towards Support for Future Tourism Using Social Exchange Theory (SET). *Journal of Tourism, Hospitality & Culinary Arts*, 12(3), 106-119

Abstract

The purpose of this article is to present a model that expresses a relationship between the local resident's perception towards developmental tourism impacts (economic, environmental and social) and their support for future tourism development. The research instrument measures the environmental, economic and social impacts and assesses the respondents' support for future tourism development. The data was collected from the local residents of different districts in Kashmir Valley. A total of 316 valid questionnaires were analyzed using AMOS-24. The results indicated that the rural residents' perception of tourism development does have an impact on their support for tourism development. The findings also showed that gender and the geographical area does moderate the relationship between their perception of tourism development impacts and their support for future tourism development.

Keywords:

Perception; future tourism support; India; Kashmir; community development

1 Introduction

In India, tourism is considered and encouraged as a model and prototype of economic growth. However, tourism development, most of the time, is bracketed with economics, culture environment, socio-political and institutional dimensions. The Endogenous Tourism Project (EPT) was an innovative and striking result of the National Tourism Policy 2002. The Endogenous Tourism Project (EPT) is a cooperative and collaborative effort of the Ministry of Tourism (MoT) and the United Nations Development Programme (UNDP) initiated in 2003. The EPT stretches over 36 Indian villages and focuses on the rural tourism experience, with thematic priorities that include human development, gender equality, strengthening decentralization, urban and rural livelihoods, energy and environment and vulnerability reduction (Explore Rural India, 2005).

The other outcome of the National Tourism Policy (2002) was the Mountain Shepherds Initiative. The Mountain Shepherds Initiative (MSI), in 2006, a community-owned and controlled ecotourism venture, which previously launched in the locality of the Nanda Devi Biosphere Reserve in Uttarakhand. This initiative was rooted in and intertwined with the social struggles, Chipko Movement (the early 1970s), Jhapto Cheeno Movement (late 1990s) and more recent efforts by the Nanda Devi Campaign to assert people's land and forest rights. With the initiation of the Mountain Shepherds Initiative (MSI), the Nanda Devi Campaign is chalking the historical and tedious task of setting up a community-owned operation, with a goal for future success without human exploitation and environmental deterioration. The campaign hopes to execute its torch-bearing thoughts in all aspects of tourism planning, regardless of any factor.

As per Rural Tourism Scheme, a total of 107 villages across the country accepted and implemented ETP and MSI, and the results have been mixed, but the success stories reflect that wherever successful, the host communities' involvement was a significant factor (Ministry of Tourism, Government of India, 2010; 2012). Along with the central government, various state governments are keen and considerate to promote Community-based Tourism (CBT) in the form of rural tourism and homestays. A few success stories can be seen in Ladakh, Jammu and Kashmir, Uttarakhand, West Bengal, Sikkim, Karnataka, Kerala and Rajasthan. The initiatives are getting help and encouragement from national banks, national and international NGOs. The idea of CBT will also create the basis for the diverse developments in the area of implementation. The social, environmental and economic impact of the CBT will enhance the chances of success of planning and execution. Table 1 reports the economic, social and environmental impacts of CBT.

Table 1: Economic, Social & Environmental Impacts of CBT

	Economic Impacts	Social Impacts	Environmental Impacts
Positive	Job Opportunities Higher Incomes More Varying Occupations Broader Economic base New activities	More contacts Increased knowledge Improved self-confidence Improved situation for women Population growth Better Social service	Increased consciousness Protection of wildlife and environment More attention to cultural heritage
Negative	More seasonal jobs Rise in prices Increased dependence Costs of development	Alienation Criminality "Disneyfication" of culture	Erosion Littering Pollution Noise

Source: Hall and Page (1999)

Numerous studies have been conducted which tested the relationship between tourism development impacts and support for future tourism development (Abdollahzadh & Sharifzadeh, 2014; Almeida et al., 2016; Nunkoo & Ramkissoon, 2011; Styliadis, 2014). The findings of these studies indicate that understanding the implications of tourism development from a resident's point of view will help to increase knowledge of factors affecting the long-term sustainable success of tourism destinations (Woo, Kim & Uysal, 2015). The present study is an attempt to explore whether the resident's perception of tourism developmental impact (economic, environmental and social) does have a bearing on their attitude towards supporting future tourism development.

2 Literature Review

Social Exchange Theory is common in the field and allied fields of social psychology. It is seen as the pioneering studies on social behaviour (Homans, 1958). Emersen (1981) observed that the concept of social exchange encompasses individuals, mutually beneficial to one another, and dependent upon each other's rewards. Previous studies contributing to the literature of SET includes Homans (1958), Thibaut and Kelley (1959) and Emerson (1962). Homans (1958) also examined the role of social behaviour during the exchange process. For example, Thibaut and Kelley (1959) indicated the manner in which the players in the linkage of exchange and contribution reap profit from the exchange process. Emerson's (1962) examined the power-authority concept between the different players' exchange process, while Blau (1964) considered social interaction as an exchange process in disguise. SET is rooted in the principle that human behaviour and social interaction are exchange activities. These are considered as tangible as well as intangible and also comprising of rewards as well as expenses (Homans, 1961). It examines how the construction of rewards and

costs in an exchange relationship affects the configuration of interaction (Molm, 1991). SET suggests that any exchange is fundamental to human behaviour (Homans, 1961).

Social and economic exchanges differ from each other in numerous ways. One, the formal profits are normally associated with economic exchanges, but these profits are not realized in the social exchange (Blau, 1964). Benefits are also exchanged intentionally and provide future responsibilities and profits cannot be anticipated (Konovsky & Pugh, 1994). There is no guarantee that the benefits will be shared or reciprocated. Hence, it can be concluded that social exchanges are limited by the factor such as insecurity, especially in the initial stages of the relationship (Whitener et al., 1998). Similar to economic exchange, there are possibilities of the future revenues in social exchanges too. However, there are uncertainties about the nature of these revenues (Blau, 1964). The long-term profits are associated with social exchanges, and short-term profits are associated with economic exchanges (Konovsky & Pugh, 1994). As per the SET, social exchange comprised of both the economic as well as the social outcomes. Whitener et al. (1998) make a note of exchanges and state that they may include benefits with finances or without any actual utility and the further reason that the latter may have a considerable influence on the social dimension of the association.

From the perspective of tourism, Sutton (1967) argued that host community-tourist meeting who may provide either an opportunity for rewarding and satisfying exchanges or it may stimulate and reinforce impulses to exploitation on the part of the host. A significant number of researchers supported the observations of Sutton (1967) (Yoon et al., 2000). These researchers revealed that the economic, environmental and social elements support the exchange process between the residents and the tourists. These researchers have also observed that the value associated with the exchange process determine the perception of residents about the tourism business and hence, decides the level of involvement of the local community in the tourism business activities. The way that residents perceive the economic, socio-cultural and environmental elements of exchange affects how they react to tourism, which includes the conative element of perception (Andriotis & Vaughan, 2003). Thus, it can be concluded that the exchange process between the local residents and the host in a tourism business encompasses social, cultural and environmental factors, in addition to the economic factors.

SET is the most prominent theory which has been used in the literature to find out the attitude of residents concerning its impact (Andereck, Valentine, & Knopf, 2005; Blau, 1962; Nunkoo & Ramikisson, 2012). SET is considered as a convenient framework to explore both the positive and negative attitude of the community members (Boley et al., 2017; Latkova & Vogt, 2012; Lee, 2013). SET opines that the residents tend to support the tourism initiatives as far as they believe that the expected benefits will outweigh the costs (Mason & Cheyne, 2000; Ko & Stewart, 2002; Dyer et al., 2007; Huttasin, 2008). Tourism is also expected to bring opportunities viz; economic, cultural

exchange and also improve the community image (Farahani & Henderson, 2014; Zhou, 2009; Shani & Pizam, 2012). The studies based on SET concluded that in an exchange atmosphere, those who find tourism more beneficial will support it, and those who find it harmful would not lend their support to tourism development initiatives within their respective communities (Sajad et al., 2017).

3 Methodology

3.1 Research Instrument

The questionnaire for the study was adopted from the studies by Latkova and Vogt (2012), Lankford and Howard (1994) and Hanafiah et al. (2013) after reviewing the literature on perception of local community towards the tourism development. Various studies (Hanafiah, 2013; Petrovic et al., 2017; Sharpley, 2014; Woosnam et al., 2009; Andereck et al., 2005) have used the items from the scales propounded by Latkova and Vogt (2012) and Lankford and Howard (1994).

3.2 Data Collection

The data was collected from the local residents of different districts in Kashmir Valley like; Anantnag, Kulgam, Pulwama, Shopian, Baramulla, Bandipora, Sopore, Budgam, Ganderbal, and Srinagar in India. The respondents were approached conveniently, and researchers made sure that there is a representation from the local rural residents of all the three geographical areas. A total of 316 filled questionnaires were analyzed using AMOS-24.

3.3 Assumptions of Parametric Testing

Before proceeding for the testing, following assumptions of parametric testing proposed by Andy (2000) were checked. First, data should be normally distributed in case of parametric testing of the hypotheses. The assumption of normality was checked using the values of skewness and kurtosis values. While skewness is the symmetry of distribution, Kurtosis denotes the peakedness or flatness of the curve. In a perfectly normal data, the value of both skewness and Kurtosis is zero (Andy, 2000; Malhotra, 2009). Hence, for a normal distribution, the values of skewness and Kurtosis should be close to zero. However, for the analysis purpose, the values of skewness and Kurtosis in the range of -2 to +2 are considered acceptable. In the present study also, the values of skewness and Kurtosis are within the range of -2 to +2. Hence, the basic assumption of normality is met.

The assumption of homogeneity suggests that the variance must be equal in the entire data. In other words, this assumption implies that several samples of respondents have the same variation. To check the homogeneity in the present study, the Levene's test for equality of variances was performed. It is based on the rule that the difference between the variances is zero in case the p-value in the Levene's test is greater than 0.05, i.e., non-significant. This implies that the variances across the

groups are equal, and hence, the homogeneity assumption is met. This test is mentioned in the test of t-test and ANOVA. Since all the assumptions of parametric testing are taken care of in the present study, therefore, we could proceed for parametric testing.

Table 2: Descriptive Analysis of Scale used in the study

Variables	No. of Respondents (N)	Skewness		Kurtosis	
		Statistic	Std. Error	Statistic	Std. Error
Economic impact (1)	316	0.627	0.137	0.741	0.273
Environmental impact (2)	316	0.167	0.137	-0.479	0.273
Social impact (3)	316	0.376	0.137	0.465	0.273
Perception (1+2+3)	316	0.042	0.137	1.670	0.273
Support for future tourism development	316	0.753	0.137	1.629	0.273

Table 2 shows that the skewness and kurtosis values fall within the tolerable range of -2 to +2. This implies that the data fulfils the basis parametric testing assumption, confirming the normal distribution of data.

4 Findings

4.1 First Order Confirmatory Factor Analysis (CFA)

The constructs such as economic impact, environmental impact and social impact were treated as the first-order latent constructs. Confirmatory factor analysis (CFA) with maximum likelihood estimation was performed in AMOS 24. Results provided good model fit (Cmin/df=2.387; GFI=0.925; AGFI=0.894; TLI= 0.902; CFI=0.921; RMSEA=0.066) with all the items loaded significantly on the expected factors (Gerbing & Anderson, 1988; Hu & Bentler, 1999; Ryu et al., 2010). Composite reliability values for EN and SI are acceptable (> 0.7). For EI, the CR value is just smaller than 0.7 (CR=0.689). The AVE values for all the three constructs are less than the acceptable value of greater than 0.5. Thus, the constructs have some issues in convergent validity as per the AVE values, but since CR values are considerably high, we can proceed for further analysis (Malhotra and Dash, 2011). HTMT score (based on the Monte Carlo Simulation) was also within the acceptable range of 0.85 (Table 4) confirming discriminant validity (Henseler et al., 2015; Gaskin & James, 2019).

Table 3: Reliability and Convergent Validity

Construct	CR	AVE
EN	0.847	0.448
EI	0.689	0.459
SI	0.741	0.530

Table 4: Discriminant Validity (HTMT Analysis)

	EN	EI	SI
EN	-	-	-
EI	0.164	-	-
SI	0.327	0.741	-

4.2 Second-order CFA

Local resident perception (LRP) is a multi-dimensional construct, and hence, second-order CFA was performed for it (Law et al., 1998; Qureshi et al., 2009). The results are presented in Table-5. Better model fit indices for second-order CFA explained the multi-dimensional nature of local residents' perception.

Table 5: Model Fit Indices for LRP (Local Resident Perception)

	Cmin/df	GFI	AGFI	TLI	CFI	RMSEA
First-Order	8.091	0.685	0.571	0.499	0.580	0.150
Second-Order	2.387	0.925	0.894	0.902	0.921	0.066

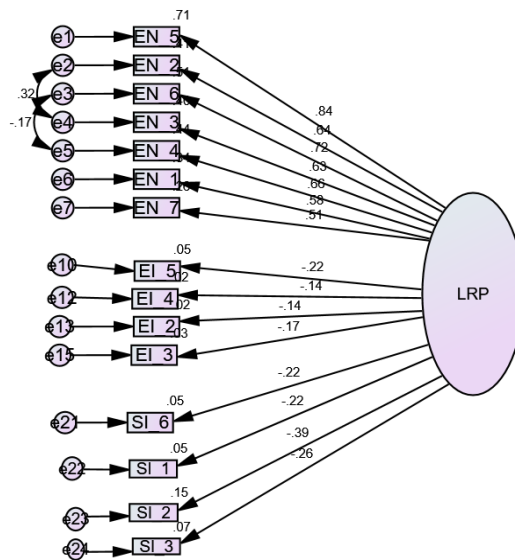

Figure 2: First-Order Model

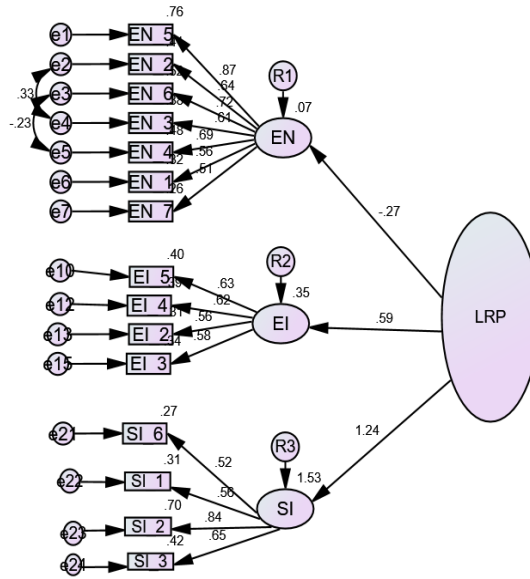

Figure 3: Second-Order Model

4.3 Structural Model

Findings as presented in Table-6 and Figure-4 indicate that the model fits the data well (Cmin/df=2.102; GFI=0.869; AGFI=0.869; TLI= 0.869; CFI=0.882; RMSEA=0.056). The study findings suggest that the local residents' perception (LRP) has a significant and positive relationship ($\beta=0.701$; p-value=0.000) with the support for future tourism. Hence, the hypothesis H_1 is supported.

Table 6: Results of Structural Model

No.	Hypothesized Path	Standardized Estimates	p-values	Decision
(Cmin/df=2.102; GFI=0.869; AGFI=0.843; TLI=0.869; CFI=0.882; RMSEA=0.056)				
1.	H01: LRP > FTD	0.701	0.000	Supported

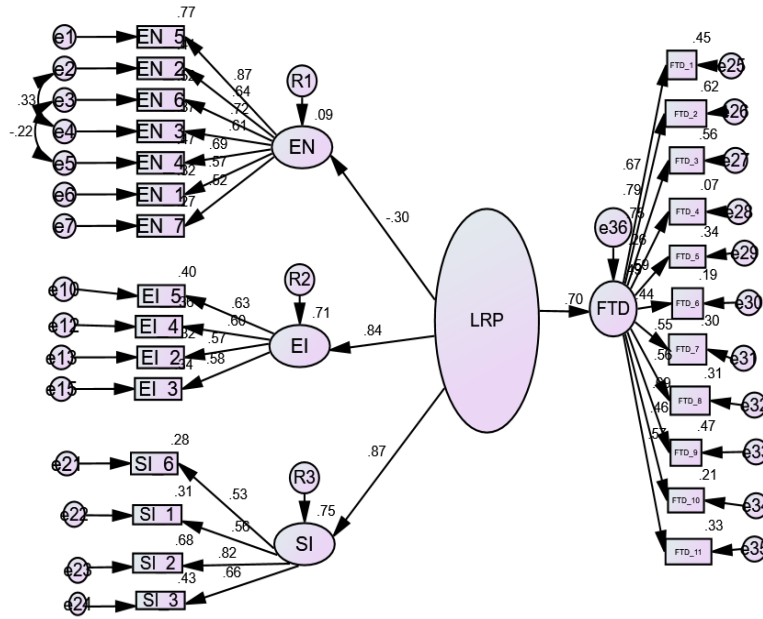

Figure 4: Structural Model

4.4 Moderation Analysis

4.4.1 With Gender as Moderator

The relationship between the LRP (Local Resident's Perception towards Tourism Development Impacts) and FTD (Support for Future Tourism Development) was validated with gender as the moderator. There were two groups, i.e., the male and the female respondents. The difference in chi-square test was employed to validate the role of moderator with the help plugin in AMOS 24 suggested by Gaskin and Lim (2018). The results show that the p-value of the chi-square difference test is significant. This suggests that the model differs across the groups. The value of chi-square for an unconstrained model is 0.000 and for the constrained model is 157.00. Thus, the hypothesis H₂ is supported. Further, the results show that the relationship is stronger for males than females.

4.4.2 With Age as a Moderator

The results show that the p-value of the chi-square difference test is not significant. This result suggests that the model does not differ across the groups. The value of chi-square for an unconstrained model is 0.000 and for the constrained model is 4.105. Hence, the hypothesis H₃ is not supported.

4.4.3 *With Education as a Moderator*

The results show that the p-value of the chi-square difference test is not significant. This suggests that the model does not differ across the groups. The value of chi-square for an unconstrained model is 0.000 and for the constrained model is 5.414. Hence, the hypothesis H₄ is not supported.

4.4.4 *With Geographical Area as a Moderator*

The results show that the p-value of the chi-square difference test is significant. This suggests that the model differs across the groups. The value of chi-square for an unconstrained model is 0.000 and for the constrained model is 11.988. Thus, the hypothesis H₅ is supported. Further, the results show that the relationship is stronger for North Kashmir than the other locations.

5 Discussion and Conclusion

The literature on the "Support for Future Tourism Development" is enriched with the testing of relationships between support for future tourism development and variables like; community attachment, overall quality of life, residents' perceptions, personal and community benefits, support for local tourism development (Cerro et al., 2017; Petrovicetal, 2016; Latkova, 2012). The present study also tested the relationship between the perception of tourism impacts and support for future tourism development. The findings are:

The result of this study indicated that the rural residents' perception of tourism development does have an impact on their support for tourism development. The support from the local community plays an indispensable role in their hospitality. The attitude of the host community is a deciding factor of the tourism development in the community, as they are in direct touch with the tourists (Rashid & Ibrahim, 2010; Yoon, 2001). Consistent with these findings, Dyer et al. (2007) indicated that the positive cultural impacts of tourism development play an important role in future tourism support. Literature is enriched with the studies, wherein; a significant relationship between the perceived impacts of tourism development and their level of support for tourism has been found. For example, various studies found that the support for future tourism by the local residents is greatly influenced by the economic impacts of the tourism development (Choi & Murray, 2010; Gursoy & Rutherford, 2004; Mbaiwa, 2005; Woo et al., 2015). On the same lines, personal benefits out of tourism development are linked with the support for tourism (Mirzaei, 2013; Pappas, 2008).

Also, there are contradictory results in the literature wherein; researchers couldn't find any significant relationship between the resident's attitude and support for future tourism development. For example, Gursoy et al. (2002) and McCool and Marti (1994)

couldn't find any connection between the perception of the impacts of tourism and future tourism development. However, many researchers have observed that perceived socio-cultural costs negatively affect the support for future tourism (Cheyne, 2000; Huttasin, 2008; Ko & Stewart, 2002).

The research findings also indicated that gender and the geographical area does moderate the relationship between perception of tourism development impacts and support for future tourism development. However, Age and Education failed to do so. In the 1990s, the impact of gender on tourism development as well as support for future tourism started to get attention from researchers (Kinnaird & Hall, 1996). Gender is now considered as an important factor for testing perceived tourism impacts (Mason & Cheyne, 2002; Harril, 2006; Nunkoo & Gursoy, 2012). Mason and Cheyne (2002) found that men are more supportive as far as tourism development is concerned in comparison to women. Also, men perceive more positive impacts of tourism than women. This finding is further supported by the studies conducted by Harrill and Potts (2003) and Nunkoo and Gursoy (2012) wherein, they found that women tend to have more negative perception than men.

The literature also indicates that the resident's perceptions of tourism development impacts vary across different age groups. Young residents are found to be more optimistic about the economic impacts of tourism development (Almeida et al., 2015; Cavus & Tanrisevdi, 2003) than older residents. Contrary to this, Tomljenovic and Faulkner (1999) and Sheldon and Abenoja (2001) indicated that older residents tend to have a positive attitude than younger residents. In all these studies, age was seen to have an impact on the attitude of residents towards tourism development viz-a-viz support for future tourism. However, in the present study, the age of the residents failed to show any significant impact on the support for future tourism.

The level of education of the local residents is found as a significant variable which has an impact on the perception of residents towards tourism development impacts and also shapes their tendency to support the future tourism developmental initiatives. For example, it has been observed in numerous studies claimed that the residents with higher education qualification have positive perception towards tourism impacts viz-a-viz; economic impacts, social impacts and environmental impacts (Almeida et al., 2016; Andereck et al., 2005; Hernández et al., 1996; Sharma & Dyer, 2009). The residents with higher qualification tend to perceive that the tourism may result in their economic prosperity whereas; the less educated residents do not seem to acquire economic benefits (Hernández et al., 1996; Almeida et al., 2016). In the present study, education was not found to have any significant influence on tourism development.

6 Future Research Directions

The future researchers may include more variables in the study and test their influence on the Support for Future Research Development. The scope of the present

study is limited to the rural communities of Kashmir Valley only. Future studies can explore the working of these variables in Jammu and Ladakh also. Due to the frequent lockdowns during the study, researchers employed Convenience Sampling technique (otherwise random sampling was planned). Future research can go for probability sampling to ensure the external validity of the work. Researchers may continue testing the modified models of community-based Tourism in various communities to understand the robust CBT model implementation as per the community setting. Moreover, the future work may be focused on the scope of creating entrepreneurial ventures viz-a-viz; CBT. The researchers may also work on crafting the integration strategies for the partnership between community and policymakers to boost the economy through sustainable community-based models.

7 About the author

Dr Irfana Rashid is working as Senior Assistant Professor in the Department of Management Studies, University of Kashmir. She has a teaching experience of 09 years at University level. She has completed her doctorate from Aligarh Muslim University in 2013. She has also qualified UGC-NET/JRF/SRF. She has completed the prestigious Faculty Development Programme from Indian Institute of Management, Ahmedabad (IIM-A) in the year 2017. She has publications in journals of national and international repute. She has also attended and presented her work in various national and international conferences.

8 References

- Almeida García, F.; Balbuena Vázquez, A.; & Cortés Macías, R. (2015). Resident's attitudes towards the impacts of tourism. *Tour. Manag. Perspect.*, 13, 33–40.
- Andereck, K. L., & C. A. Vogt. (2000). The Relationship between Residents Attitude towards Tourism and Tourism Development Options. *Journal of Travel Research*, 39 (1), 27-36.
- Andriotis, K., & Vaughan, R. D. (2003). Urban residents' attitudes toward tourism development: The case of Crete. *Journal of Travel Research*, 42, 172-185.
- Blau, P. M. (1964). Exchange and power in social life. *New York: John Wiley and Sons*.
- Cavus, S.; & Tanrisevdi, A. (2003). Residents' Attitudes toward Tourism Development: A Case Study in Kusadasi, Turkey. *Tour. Anal.*, 7, 259–269.
- Choi, H.C.; & Murray, I. (2010). Resident attitudes toward sustainable community tourism. *J. Sustain. Tour.*, 18, 575–594.
- Dyer, P.; Gursoy, D.; Sharma, B.; & Carter, J. (2007). Structural modeling of resident perceptions of tourism and associated development on the Sunshine Coast, Australia. *Tour. Manag.*, 28, 409–422
- Emerson, R. M. (1962). Power-dependence relations. *American Journal of Sociological*, 31-41.
- Gursoy, D.; Milito, M.C.; & Nunkoo, R. (2017). Residents' support for a mega-event: The case of the 2014 FIFA World Cup, Natal, Brazil. *J. Destin. Mark. Manag.*, 6, 344–352.
- Hanafiah, M.H., Jamaluddin, M.R., & Zulkifly, M.I. (2013). Local Community Attitude & Support towards Tourism Development in Tioman Island, Malaysia. *Procedia Social & Behavioral Sciences*, 105, 792-800.

- Hanafiah, M.H., M.F. Harun and Jamaluddin M.R., (2010). Bilateral Trade and Tourism Demand. *World Applied Sciences Journal*, 10 (Special Issue of Tourism & Hospitality), 110-114.
- Hanafiah, M.H., M.F. Harun & Jamaluddin M.R., (2010). Bilateral Trade and Tourism Demand. *World Applied Sciences Journal*, 10 (Special Issue of Tourism & Hospitality), 110-114.
- Harrill, R. (2004). Residents' attitudes toward tourism development: A literature review with implications for tourism planning. *J. Plan. Lit*, 18, 251–266.
- Homans, G. C. (1958). Social behavior as exchange. *American Journal of Sociology*, 63, 597-606.
- Homans, G. C. (1961). Social behavior. New York: Harcourt, Brace, and World.
- Huttasin, N. (2008). Perceived Social Impacts of Tourism by Residents in the OTOP Tourism Village, Thailand. *Asia Pac. J. Tour. Res.*, 13, 175–191.
- Ibrahim, Y.; & Rashid, A. (2010). Homestay Program and Rural Community Development in Malaysia. *J. Ritsumeikan Soc. Sci. Humanit.*, 1, 7–24.
- Kashmir Tourism; Jammu & Kashmir: Heaven on Earth. Available online <https://www.thomascook.in/india-tourism/kashmir>.
- Kinnaird, V.; & Hall, D. (1996). Understanding tourism processes: A gender-aware framework. *Tour. Manag.*, 17, 95–102.
- Ko, D.W.; & Stewart, W.P. (2002). A structural equation model of residents' attitudes for tourism development. *Tour. Manag.* 23, 521–53.
- Konovsky, M. A., & Pugh, S. D. (1994). Citizenship behavior and social exchange. *The Academic of Management Journal*, 37(3), 656-669.
- Lankford, S. V., and D. R. Howard. (1994). Developing a Tourism Impact Attitude Scale. *Annals of Tourism Research*, 21 (1): 121-39.
- Latkova, P., & Vogt, C. A. (2012). Resident's attitude towards existing and Future Tourism Development in Rural Communities Scale. *Journal of Travel Research*, 51(1), 50-67.
- Mason, P.; & Cheyne, J. (2000). Residents' attitudes to proposed tourism development. *Ann. Tour. Res.*, 27, 391–411.
- Mbaiwa, J.E. (2005). The Socio-cultural Impacts of Tourism Development in the Okavango Delta, Botswana. *J. Tour. Cult. Chang.*, 2, 163–185.
- Mirzaei, R. (2013). Modeling the Socioeconomic and Environmental Impacts of Nature-Based Tourism to the Host Communities and Their Support for Tourism: Perceptions of Local Population, Mazandaran, North of Iran. Justus Liebig University Giessen: Giessen, German.
- Molm, L. D. (1991). Social exchange: Satisfaction in power-dependence relations. *American Sociological Review*, 56(4), 475-493.
- Nunkoo, R. (2015). Toward a More Comprehensive Use of Social Exchange Theory to Study Residents Attitudes to Tourism. *Procedia economics & Finance*, 39, 588-596.
- Nunkoo, R & Gursoy, D. (2011). Residents Support for Tourism: An Identity Perspective. *Annals of Tourism Research*, 39 (1), 243-268.
- Nunkoo, R.; & Gursoy, D. (2012) Residents' support for tourism: An identity perspective. *Ann. Tour. Res.*, 39, 243–268.
- Pappas, N.V. (2008). City of Rhodes: Residents' Attitudes toward Tourism Impacts and Development. *Anatolia*, 19, 51–70.
- Woo, E.; Kim, H.; & Uysal, M. (2015). Life satisfaction and support for tourism development. *Ann. Tour. Res.*, 50, 84–97.
- World Commission on Environment and Development. (1987). *Our Common Future*. New York: Oxford University Press.

- Yanes, A., Zielinski, S., Cano, M.D., & Kim, S. (2019) Community-Based Tourism in Developing Countries: A Framework for Policy Evaluation. *Sustainability*, 24 (2). 20-34.
- Yang, L., & Wall, G. (2009). Authenticity in ethnic tourism: Domestic tourists' perspectives. *Current Issues in Tourism*, 12(3), 235–254.
- Yoon, Y., Gursoy, D., & Chen, J. (2001). Validating a tourism development theory with structural equation modeling. *Tourism Management*, 22(4), 363-372.
- Yusof, Y., Ibrahim, Y., Muda, M. S., & Mohd Amid, W. (2012). Community based tourism and quality of life. *Review of Integrative Business & Economics Research*, 1(1), 335–345.
- Zapata, M. J., Hall, C. M., Lindo, P., & Vanderschaeghe, M. (2011). Can community-based tourism contribute to development and poverty alleviation? Lessons from Nicaragua. *Current Issues in Tourism*, 14(8), 725–749.