

Design and Control of a Multifingered Anthropomorphic Robotic Hand

Ahmed Jaffar, M.Saiful Bahari, Cheng Yee Low, Roseleena Jaafar

Abstract — This work describes a multifingered anthropomorphic robotic hand with fourteen degrees of freedom which is able to mimic the functional motions of a biological hand especially in handling complex objects. The actuation mechanisms consisting of micro servomotors, pulleys and belts are connected to the finger joints and thereby bending and extending the fingers. Two kinds of sensors, i.e. force sensor and light dependent resistor, are integrated into the system. The robotic hand can be controlled via a graphical user interface embedded with control codes or a joy stick integrated with a control board. Furthermore, the robotic hand is able to operate autonomously with the aid of the sensory elements and the embedded control software. Workability tests showed the capability of the system to move every finger individually and to perform grasping tasks on objects with varying sizes and geometries such as a tennis ball and a screw driver.

Index Terms- robotic hand, degree of freedom, mechanism

I. INTRODUCTION

Among the vast applications of robotics, robotic assistance in human daily life and has been the major factor that contributes to its development. The focus on the anthropomorphism robotic limbs is currently undergoing a very rapid development. The creation of a multifingered anthropomorphic robotic hand is a challenge

Manuscript received July 2011. This work was supported by the Ministry of Science, Technology and Innovation of Malaysia under the eScienceFund with the grant number 02-01-01-SF0142.

Ahmed Jaffar is with the Faculty of Mechanical Engineering, Universiti Teknologi MARA, 40450 Shah Alam, Selangor, Malaysia. (phone: 00-603-5543-5161; fax: 00-603-5543-5160; e-mail: ahmedjaffar@salam.uitm.edu.my).

Mohd Saiful Bahari is with the Faculty of Mechanical Engineering, Universiti Teknologi MARA, 40450 Shah Alam, Selangor, Malaysia. (e-mail: saiful_mechanical@yahoo.com.my).

Cheng Yee Low is with the Faculty of Mechanical Engineering, Universiti Teknologi MARA, 40450 Shah Alam, Selangor, Malaysia. (e-mail: low.uitm@gmail.com).

Roseleena Jaafar is with the Faculty of Mechanical Engineering, Universiti Teknologi MARA, 40450 Shah Alam, Selangor, Malaysia. (e-mail: roseleena_jaafar@yahoo.com).

which demands innovative integration of mechanical, electronics, control and embedded software designs.

II. LITERATURE REVIEW

The normal human hand has a set of hand which includes palm and fingers. There are five fingers in each hand, where each finger has three different phalanxes which are Proximal, Middle and Distal Phalanxes. These three phalanxes are separated by two joints, called interphalangeal joints (IP joints). The IP joints function like hinges when bending and straightening the fingers and the thumb. The IP joint closest to the palm is called Metacarpals joint (MCP). Next to the MCP joint is the Proximal IP joint (PIP) which is in between the Proximal and Middle Phalanx of a finger. The joint near the end of the finger is called the Distal IP joint (DIP). The PIP and DIP joints both have one Degree of Freedom (DOF) owing to rotational movement [2].

The thumb is a complex physical structure among the fingers and only has one IP joint between the two thumb phalanxes. Except for the thumb, the other four fingers (index, middle, ring and pinky) have similar structures in terms of kinematics and dynamics features. Average range of motion among the four fingers for flexion-extension movement is 65° at the DIP joint, 100° at the PIP joint and 80° at the MCP joint while the abduction-adduction angles for the index finger have been measured as 20° at the MCP joint[2,3]. Figure 1 illustrates the structure of the human finger.

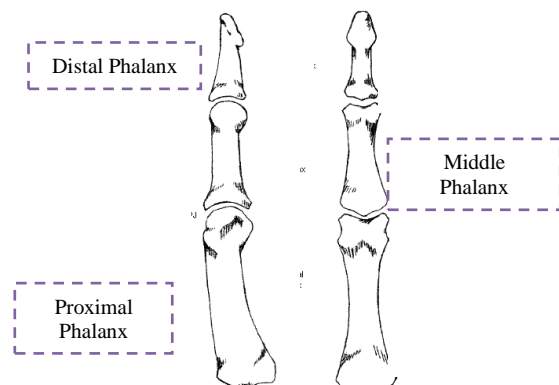

Fig 1: Structure of Human Finger. [1]

Tendons allow each finger joint to be straightened. Pulley system in a human finger keeps the flexor tendons close to the bone, thus optimizing the biomechanical functioning of the flexor tendons. The pulleys control the moment arm, excursion, and joint rotation produced by the flexor tendons [1]. This will result in flexion-extension movement in a finger. Figure 2 explain the arrangement of flexor tendons and pulleys in a finger.

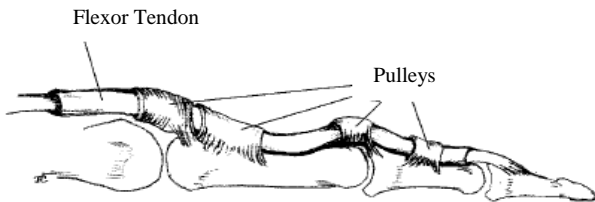

Fig 2: Arrangement of flexor tendons and pulleys. [1]

Other than tendons and pulleys system, nerve is another important system in a human hand. The nerves system is a natural sensing system in human anatomy which carries signals from the brain to the muscles that move the arm, hand, fingers, and thumb. It also carries signals back to the brain about sensations such as touch, pain, and temperature. [4]

III. THE HUMAN HAND

The human hand has been cited as the important limb that develop the ability of human brain to form essential activities in life. The neural architecture creates the capability for the hand to varieties of interaction to the world. The nerves are what trigger the muscle to generate force. The tissues in muscle tighten and relax controlling the force applied. Two sets of muscle act on the hand. Extrinsic located in the forearm which is less powerful while the intrinsic that is located within the hand itself is much stronger. Most of all dexterity and flexibility of hand is attributed by the intrinsic muscle. Some muscles act directly on the bones and others act through tendons. Flexor is used to close fingers to grip object and extensors are used to open the hand again. [5, 9]

Our hand is supported by lot of bones and provides movement to each parts of the hand from the fingertips to the elbow. The human hand can perform all the necessary types of grasping. With 25 degrees of freedom human hand is very flexible and versatile. The basic types of hand grasping are cylindrical grasp, tip grasp, hook or snap grasp, palmer grasp, spherical grasp and lateral or key pinch grasp. A sketch of human hand is shown in figure 3. [6]

Our hand supported by a lot of bones which built and provide movement to each parts of the hand from the fingertips to the elbow. The human hand can perform all the necessary type of grasping. With 25 degree of freedom human hand is very flexible and versatile. [6] The basic types of hand grasping are cylindrical grasp, tip grasp, hook or snap grasp, palmer grasp, spherical grasp and lateral or key pinch grasp shown in Figure 3.

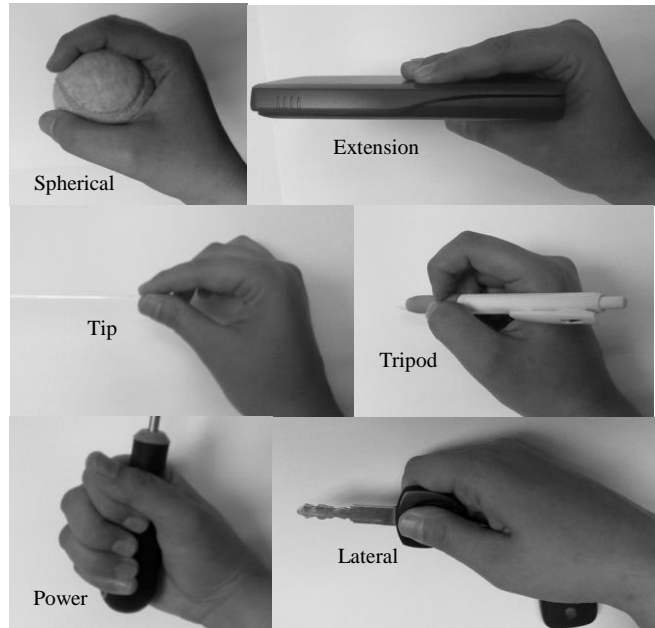
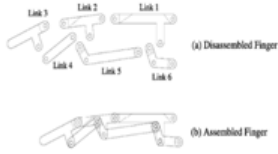
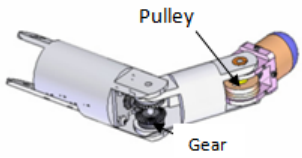
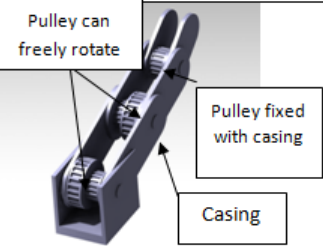

Fig 3: The Basic Types of Hand Grasping

IV. DESIGN CONCEPT

From the literature review, three concepts of design are established as shown in Table 1 with the study of design analysis for a better design. Selected design is the combination between a belt and a pulley system. To generate movement of finger, the servo motor will be replaced by a DC motor for easy control of the movement of finger and set an angle of movement. The fingers of a robot hand should preferably be high in coefficient of friction to enable secure holding of objects. In addition, a large contact area is preferably established between the fingers and the object. Enlargement of the contact area between a finger and the held object requires the finger to be given high flexibility so that it can deform in compliance with the shape or profile of the object.

Table 1: Design Concept Selection

Design Concept	Mechanism	Actuation	Motion Control
	<ul style="list-style-type: none"> - Combination of linkage. - One finger need six link 	<ul style="list-style-type: none"> - Need one servo motor for one finger. - Movement not smooth - Angle of movement limited. 	<ul style="list-style-type: none"> - Using joystick with five button to control motor each finger - Can control using GUI with computer interface - Automatic movement depends on Microchip program.
	<ul style="list-style-type: none"> - Combination gear and pulley 	<ul style="list-style-type: none"> - Need two dc motor for one finger - Need two switch to control the movement. - Angle of movement almost similar to human finger. 	<ul style="list-style-type: none"> - Using joystick with 10 button to control motor each finger - Can control using GUI with computer interface - Automatic movement depends on Microchip program.
	<ul style="list-style-type: none"> - Combination of pulley and belt. - Two pulleys can freely rotate. - One pulley is fixed with casing of finger. 	<ul style="list-style-type: none"> - Need one servo motor for one finger - Movement smooth compare with linkage design - Angle of movement can almost similar with human finger. 	<ul style="list-style-type: none"> - Using joystick with five button to control motor each finger - Can control using GUI with computer interface - Automatic movement depends on Microchip program.

V. DESIGN OF ACTUATION MECHANISM

The actuation mechanism is designed based on the internal actuation concept in order to simplify the connection between the actuator and the driving mechanism of the finger. The distance between the servomotors and pulleys that are connected together by a timing belt was short as compared to the external actuator type which normally located outside the palm or fingers. Figure 4 shows the basic concept of an open belt pulley system. The diameter of pulley A is bigger than pulley B for adjusting the angular position and speed between pulley A and B.

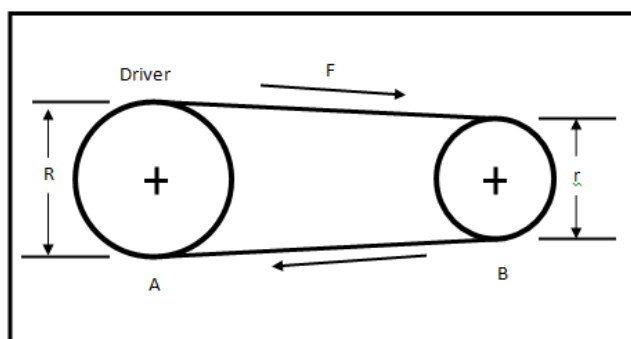

Fig 4: Open Belt Pulley System Concept

Servo motors have the limitation of only be able to rotate 180°. To eliminate this limitation, the pulley system has to be configured as shown in Figure 5. Pulley A as a driver will rotate 180° and will increase the rotation of pulley B. Pulley B will then increase the rotation of pulley C. As a result the last pulley will rotate more than 180°.

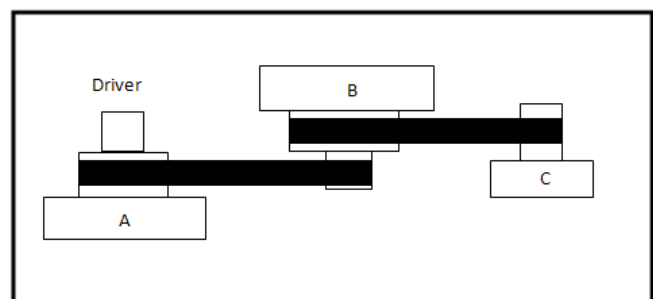

Fig 5: Variable Speed of Pulley

The basic idea of this finger system is to drive the distal, middle and proximal phalanx's mechanically using pulleys and timing belt. A servomotor drives the MCP joint pulleys. As the MCP joint pulleys rotate, it would drive the PIP joint pulleys. The PIP joint pulleys subsequently drive the DIP joint which is fixed at the distal phalanx. The joint pins allow the pulleys to be in position and rotate within its axis. Combination of these components produces a pulley

system for the robot finger as shown in Figure 6. Servomotor was used as an actuator in this project as it offers high torque at low rotational speed, compact size and very light in weight.

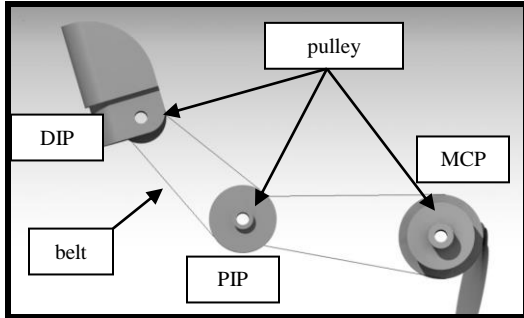

Fig 6: Combination of Belt and Pulley

The differential pulley concept was adopted in order to get a higher torque over a short distance. Differential pulley is a set of fixed pulleys with different radii, R and r as shown in Figure 7. These different radii will create mechanical advantage (MA) on each rotation of the pulley. MA is a factor by which a mechanism of pulley multiplies the force or torque applied to system. Neglecting the friction, mechanical advantage was given by this formula;

$$MA = \frac{2R}{R-r} \quad (\text{Eq.1})$$

For MCP Joint:
 $MA = \frac{2(10)}{10-7.5} = 8$

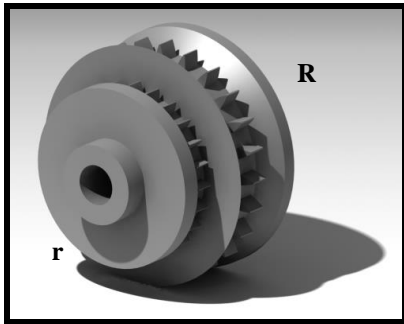

Fig 7: Differential R and r for Radius

Smaller differences between the radius of the pulleys result in a larger mechanical advantage. Within this project, the MA establishes from the MCP joint and PIP Joint differential pulleys are 8 and 9 respectively. Table 2 shows the pulley radius for each joint of the index finger.

Table 2: Pulley Radius and MA for Each Joint of Index Finger

Pulleys/Joints	Pulleys/Differential Pulleys Radius (mm)		Mechanical Advantage (MA)
	Large	Small	
Servomotor	24		0
MCP	10	7.5	8
PIP	9	6.5	9
DIP	6		0

VI. KINEMATICS ANALYSIS

In most of the natural grasping movements, the thumb comes from the opposite direction to the other fingers. This is also considered in the design and opens at all the demanded grasping areas. Each finger is actuated by one servo motor, whereas the rotation will be transferred over a gear belt mechanism. Thus there are three gears in the finger, one for every limb connected by a belt and with a fixed gear at the last segment shown in figure 9. So by the rotation of the motor, it generates the movement of all limbs in natural motion. An exception is the thumb with only two limbs, but the function principle is the same. Furthermore the determination of the correct ratio between the motor rotation and the limb movement was a very difficult part. In this framework a first prototype of a multifingered anthropomorphic hand has been developed.

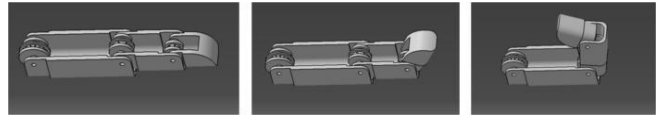

Fig 8: Sequence of Movement

It is important to point out that robotic hand is designed primarily for grasping tasks. The design approach is based on underactuated mechanisms reproducing most of the grasping behaviors of the human hand without augmenting the mechanical and the control complexity. In general, for an underactuated hand, the correct choice of the characteristic of the elastic elements and the correct placing of the mechanical stops allows a natural wrapping movement of the finger around the object, In order to achieve a correct finger movement the object should touch first the proximal phalanx, then the middle and finally the distal phalanx as shown in Figure 9.

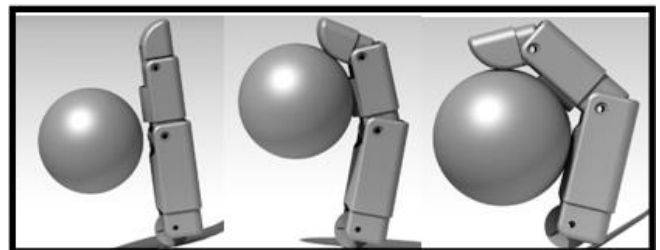

Fig 9: Finger Movement.

The kinematic behavior of the fingers joints is analyzed using the Denavit-Hartenberg method. The direct kinematics of the fingers is solved to determine the relationship between the angular positions of each finger joints with the position and orientation of the finger tip. The schematic of finger lying on the X-Y plane with the MCP Joint fixed to the palm is shown in Figure 10. The parameters of the finger phalanxes are shown in Table 3.

Table 3: Parameters of the Finger Phalanxes

Finger Joints	Range of Angular Displacement (°)	Length of Finger Phalanxes (mm)
MCP	θ_1 0-80	l_1 40
PIP	θ_2 0-100	l_2 30
DIP	θ_3 0-65	l_3 30

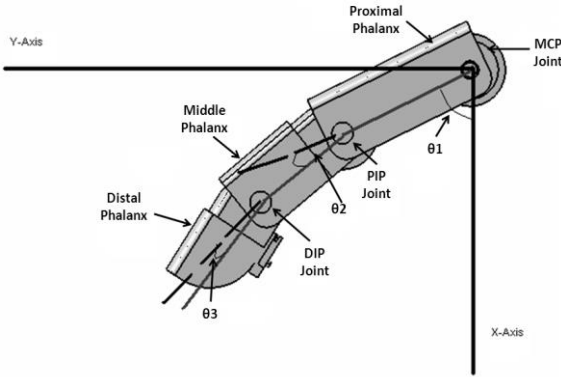

Fig 10: Coordinate Frames for the Analysis of Finger Kinematics

The Denavit-Hartenberg convention involves the joint angle θ_i , the phalanx offset d_i , the phalanx length l_i and the phalanx twist α_i for the calculation of the position and direction of the finger tip. Since the abduction-adduction of the MCP joint was neglected, the values of the phalanx offset d_i and the phalanx twist α_i become zero. Hence the equation describing the position and orientation of the tip of the finger can be simplified as below:

$$X_{\text{fingertip}} = l_1 \cos \theta_1 + l_2 \cos (\theta_1 + \theta_2) + l_3 \cos (\theta_1 + \theta_2 + \theta_3) \quad (\text{Eq. 1})$$

$$Y_{\text{fingertip}} = l_1 \sin \theta_1 + l_2 \sin (\theta_1 + \theta_2) + l_3 \sin (\theta_1 + \theta_2 + \theta_3) \quad (\text{Eq. 2})$$

$$\theta_{\text{fingertip}} = \theta_1 + \theta_2 + \theta_3 \quad (\text{Eq. 2})$$

A trajectory profile was obtained by using MATLAB[®] software to simplify the DH parameter plotting and solution for the forward kinematics problem as in equations above. Figure 11 shows the working envelope generated for mechanical linked finger. The trajectory profile covers the almost the same ranges of movement of a human finger [8], thus enable the functionality of this robot finger to be close to the human finger.

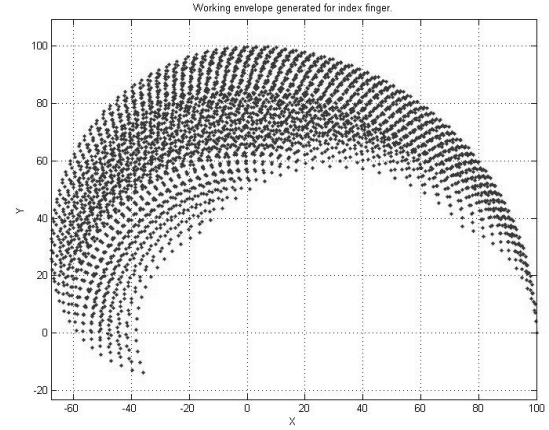

Fig 11: Trajectory Profile for Mechanical Linked Finger

VII. PROTOTYPE FABRICATION

The prototype was fabricated using Rapid Prototyping (RP) technique. RP is an advance technique which utilizes automated fabrication of physical model or prototype from computerized data or CAD system for visualization, testing and verification. It works by forming desired shape through adding or removing layers of material. There are several of RP techniques can be use to produce this finger prototype such as Stereolithography (SLA), Selective Laser Sintering (SLS), Laminated Object Modeling, Ballistic Particle Manufacturing and many others. Within this project; the InVision[®] XT 3-D Modeler machine using the SLA technique was used. It uses the acrylic plastic as the material with tensile modulus and tensile strength are 1772 MPa and 34 MPa respectively.

The advantage of using the SLA technique is within the resolution and accuracy of its final product. It can maintain the dimensional accuracy of the built parts within 0.1mm which close to the physical product being modeled by CATIA[®]. Figure 12 shows the complete system of the prototype robotic hand and its components.

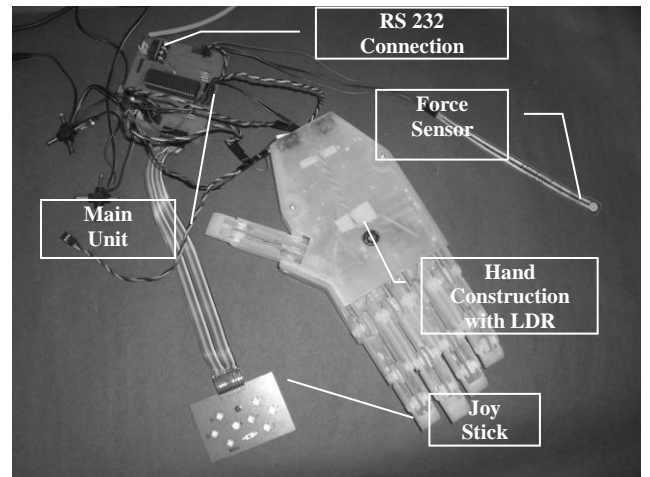

Fig 12: Complete Construction

VIII. ACTUATOR FOR EACH FINGER

This robotic hand deploys five micro servos which provide a rotation in a range of 0° to 180° . An internal circuit has been implemented to measure and regulate the movement. This regulation is done by supplying an appropriate signal to the input. The frequency of this signal has to be 40 Hz. Converted into the timescale; a period length of 25ms is needed. Depending on the pulse width of the high gauge in a period the motor will turn. The range of the pulse width has to be between 0.5ms – 2.5ms, whereas a pulse of 0.5ms causes a rotation to 0° . Hence a high time of 2.5ms drives the motor to 180° . By applying a signal with any high pulse in the requested range and with the required frequency, it is feasible to reach every angle between 0° - 180° . The function of the servomotor is clarified in the following Figure13.

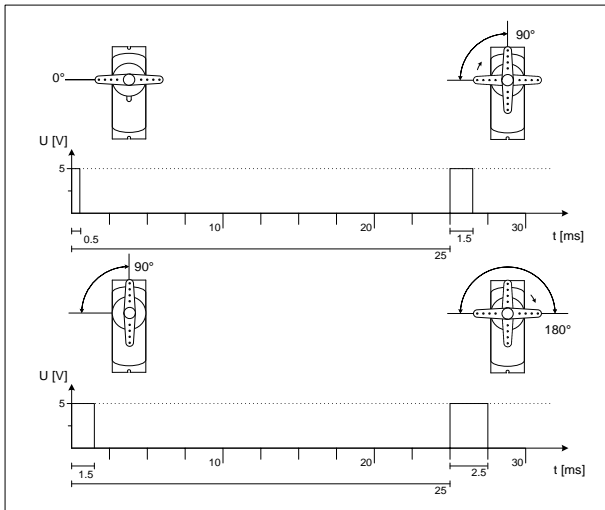

Fig 13: Servomotor Function

IX. MAIN UNIT

The design and layout of an appropriate circuit board was one of the main aspects in developing the robotic hand. Figure 14 shows the layout of the main printed circuit board. In the following there is an explanation of the main elements of this board with the auxiliary circuits: the microcontroller, the communication module and the voltage regulator. Figure 14 shows the full circuit design of main unit for top and bottom layer.

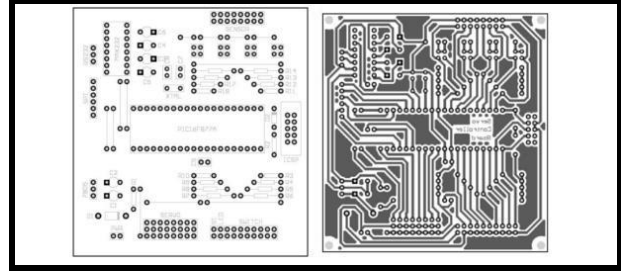

Fig 14: Final Layout of the Main Unit (Top Layer, Bottom Layer)

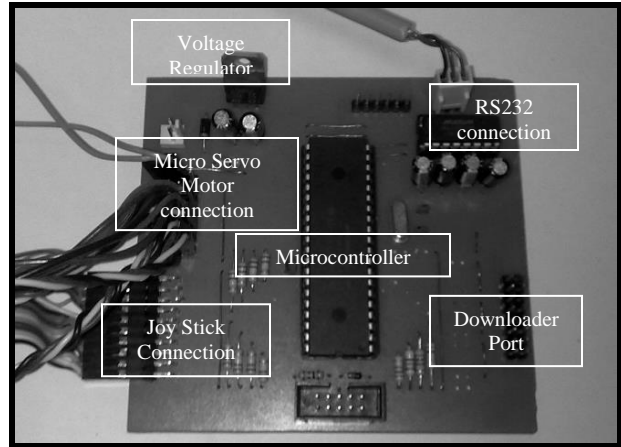

Fig 15: Main Unit

The preceding project stage has disclosed that the most suitable microcontroller for this task is the PIC 16F877A. For the demanded operation it is essential to connect it correctly with some additional devices. These are fundamental frequency pulses by an external crystal with 20MHz and two capacitors. Another option for running this device is by using the internal oscillator, but the frequency is not sufficient for this application. Also the stability of this frequency is not consistent enough. Causes are the temperature, as one example.

A microcontroller is equipped with several ports indicated by the letter R.A-E. Each Port consists of at least three to eight pins at which each has its own special feature. The ports A and E are connected to an internal analogue-digital converter, which offers the handling of analogue voltage input. This is very useful for getting reading from the sensors.

For the application of the robotic hand there is one force sensor wired to RA2 and another one, a light depending resistor (LDR), to RA1. This board also allows the enhancing of the construction with additional force sensors. One for each finger can be connected to the remaining inputs of Port A and E.

The complete digital Port B is used for the connection of the controller board to serve a push-button based control method. The digital Port is equipped with a TTL buffer and can only detect determined values. These are high gauge accomplished with +2V to +5V and low with 0V. Therefore the input pins are connected over a 1k Ω resistor with 5V. If

a button is pressed, the input will be connected with GND resulting 0V.

Furthermore, the connection of a resistor in combination with a push-button at pin 1 is for resetting the device when a failed or unexpected in-use sticking occurs. The pin input is low active so the button will connect the pin with the ground if the reset is requested. This function is only planned in the first concept. With the final layout, a reset is only possible to interrupt the power supply with the specific switch.

X. METHODS OF CONTROL THE FINGER MOVEMENT

These robotic hands use three types of controller to control the movement of each finger as below:

- I. GUI (Graphical user interface)
 - Combination of programming and visual basic to control the movement of each finger. All fingers can operate at same time and can simulate like human hand by control a consol at computer screen shown in figure 18.
- II. Programming
 - Programming is downloaded to microcontroller to make each finger to act like human hand and depend on need of movement.
- III. Manually control
 - Each finger can be controlled by using own button to simulate a movement.



Fig 16: GUI controller

To add function of this hand, light dependent resistor (LDR) sensor will be added at the palm at robotic hand. To enhance the automation in this system, the LDR comes into operation with the aim of detecting an approaching object. The light depending resistor changes the value in relation to the incident light. It is placed in the middle of the palm. Thus an approaching object will reduce the incident light and cause a decrease of the resistance value as well. This

alteration will be noticed by the microcontroller in the form of several voltages provided by the voltage divider. One threshold must therefore be set for a determined distance from the object to the palm. If the object comes nearer than this limit, the hand will perform the grasping movement. Considering the brightness in different environments, this threshold could be set by using the GUI.

XI. TEST RESULTS

The test outlines performance of several grasping motions with different objects. First there was an attempt to grasp a ball as an example for round objects. The GUI and controller board were used to simulate this grasping action as shown from Figure 17. The other attempts include the handling of cylindrical objects such as gripping a screwdriver shown in Figure 18.

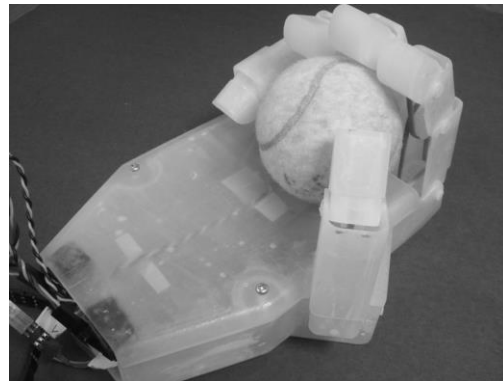

Fig 17: Ball grasping

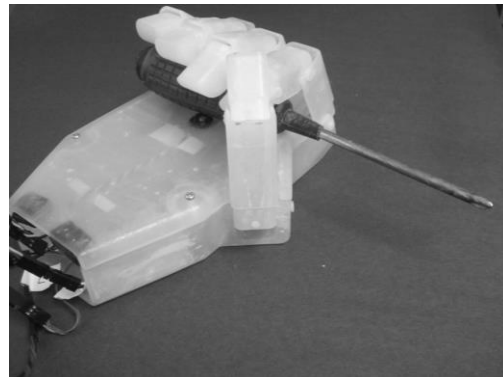

Fig 18: Grasping of a Screwdriver

These final tests have shown that the system is able to perform rough grasping movements on daily objects. The next scenario is to hold a pencil using the precision grip. However this simulation failed because the force transmission of the motor over the gear-belt mechanism is not strong enough. Due to this problem, the designed grasping hand is not that universal to grasp whatever objects with the force provided by the motors. Therefore future work needs to be done to improve on the current design.

XII. CONCLUSION

A multifingered anthropomorphic robotic hand encompassing innovative interactions of mechanical, electronics, software and control solutions has been successfully designed, fabricated and tested. The integration of sensory and actuation devices was a complex and troublesome development phase. All these connections and operations must be programmed precisely. Future research will make use of a shape memory alloy (SMA) wire to replace the servo motors. The usage of SMA in replacement of servo motors will enhance the performance of the robotic hand and provide a silent grasping motion.

ACKNOWLEDGEMENT

This research project is financially supported by Ministry of Science, Technology and Innovation Malaysia (MOSTI) under E-Science Grant.

REFERENCE

- [1] Jan A. Combs (2000). It's Not "Just A Finger"; Walter Reed Army Medical Center, Washington DC and The Curtis National Hand Center, Union Memorial Hospital, Baltimore. MD Journal of Athletic Training vol.35 (2):168-178.
- [2] Neil A. Davidoff, Andris Freivalds (August4, 1993). "A graphic model of the human hand using CATIA". Department of Industrial and Management Systems Engineering, Pennsylvania State University, University Park, PA 16802, USA
- [3] Jung Won Kang, Hyun Seok Hong, Bong Sung Kim , Myung Jin Chung, "Work Assistive Mobile Robots Assisting the Disabled in a Real Manufacturing Environment", *International Journal of Assistive Robotics and Mechatronics, Volume 8 Number 3, September 2007*.
- [4] Yukio Saito, Hiroshi Negato, Harumi Kobayashi, "Research on Intelligent Motorized Prosthetic Hand by Functional Analysis of Human Hand", *Proceedings of the 4th COE Workshop on Human Adaptive Mechatronics (HAM), 2-3 March 2007, Tokyo Denki University, Japan*
- [5] S. Pheasant, "Bodyspace: Anthropometry, Ergonomics and Design", *Taylor and Francis (Printers) Ltd., 1986, pp 125-127*.
- [6] Ashley, S., 1995, "Rapid Prototyping is Coming of Age," *Mech. Eng. ~Am. Soc. Mech. Eng.*, **117**, No. 7, pp. 63-68.
- [7] Jamaluddin Abdullah, Ahmad Yusoff Hassan."Rapid Prototyping in Orthopaedics: Principles and Applications". UPM.
- [8] M. Peters, K. Mackenzie, and P. Bryden, "Finger Length and Distal Finger Extent Patterns in Humans", *American Journal of Physical Anthropology*, **117**: 209-217 (2002).
- [9] Patent Application Publication, United State, Pub. No.: US2006/0158146A1, Pub Date: Jul 20 2006 pp 1- 25
- [10] Patent Application Publication, United State, Pub. No.: US2007/0018470 A1, Pub Date: Jan 25 2007 pp 1- 25
- [11] A multi-fingered hand prosthesis Jingzhou Yang a,* , Esteban Pe-na Pitarch b,Karim Abdel-Malek a, Amos Patrick a, Lars Lindkvist c a Digital Humans Laboratory, Center for Computer-Aided Design, The University of Iowa,116 Engineering Research Facility, Iowa City, IA 52242-1000, USA b Departament Enginyeria Mecanica, Universitat Politecnica De Catalunya (UPC), Av. Bases de Manresa, 61-73, 08240 Manresa, Spain

Ahmed Jaffar is currently a Professor and the Dean of the Faculty of Mechanical Engineering, Universiti Teknologi MARA, Malaysia. He received his B.Eng. (Hons) Mechanical from this university and has more than 25 years industrial experience since 1978. He joined this university as an academician from the year 2000. He holds a Ph.D degree from the University of London, U.K. in 1998. He is a Professional Engineer and a corporate member of the Board of Engineers Malaysia. His research interests are in mechatronics, robotics and automation and advanced manufacturing system. He led and completed three (3) research projects and currently leading another two (2) on-going projects with a total grant valued at MYR600K. He has published more than 50 national and international journals and proceedings.

Mohd Saiful Bahari is currently a lecturer at the Faculty of Mechanical Engineering, Universiti Teknologi MARA, Malaysia (UiTM). He received his Degree of Mechanical Engineering in 2004 from UiTM. In 2011, he in progress to get his master from the UiTM. His research focuses on mechatronics, design methodology for mechatronic systems and model-based systems engineering.

Cheng Yee Low is currently a lecturer at the Faculty of Mechanical Engineering, Universiti Teknologi MARA, Malaysia. He received his Master of Science in Mechatronics in 2004 from King's College London, United Kingdom. In 2009, he earned his Ph.D. from the Heinz Nixdorf Institute, Paderborn University, Germany. His research focuses on mechatronics, design methodology for mechatronic systems and model-based systems engineering. He is a member of the Board of Engineers Malaysia.

Roseleena Jaafar is currently a senior lecturer at the Faculty of Mechanical Engineering, Universiti Teknologi MARA, Malaysia. She has over 13 years of experience from teaching in private colleges and government educational institutions. Her first degree in mechanical engineering was from Brighton Polytechnic, UK and later she earned her masters degree in Computer Integrated Manufacturing from the Loughborough University of Technology, UK in 1992. Her research interest, work and findings have evolved in the areas of robotics, automation, manufacturing processes and systems.