

PROGRAMMING THE INTEGRATION OF ROBOT MOTION AND VISION FOR AN INDUSTRIAL ROBOT

Mohamad Farizal Bin Rajemi
Fakulti Pengurusan Teknologi
Universiti Utara Malaysia, 06010 Sintok, Kedah
farizal@uum.edu.my

Abstract: The paper reports on work recently carried out to integrate the ASEA IRB 6 industrial robot motion with camera Baxall CD9752 vision system. The development of the software includes the synchronization of the robot arm, detection of an object on test table and the operation of the robot arm to pick up the object on the test table. In evaluating the experiment, 7 random points are being selected in the active camera area to determine the difference between the actual location of the end-effector and the calculated calculation using two methods i.e. the trigonometric solutions and the Denavit-Hartenberg (DH) parameters. In so doing, both the concepts of forward and inverse kinematics are demonstrated.

INTRODUCTION

The use of the robot vision is becoming very important in the industries. The employment of the industrial robot with a robot vision has provided industries with the flexibility to operate robots from a distance without worrying about the hazards that may occur due to being close to their operation. Besides that the implementation of the robot also improves the efficiency of the production line, enabling maximization of both productivity and product quality.

The main objective in this paper is to integrate the camera vision with the ASEA IRB-6 industrial robot. The robot should move according to the location defined in the camera imaged displayed in the supervising computer. In order to achieve this objective a camera is mounted vertically above the test table at a certain height to capture the image on the test table. The software used to control the robot and to display the image of the camera is Visual Basic 6.0. To integrate the camera image and the motion of the robot arm, the camera should be calibrated to find the relationship between the coordinates in pixels of the camera and the coordinates of end effector of the robot arm with respect to the axis origin of the robot. The test table should also be fixed at certain location so that the integration of the camera image and the robot coordinates is not affected.

The second objective is to make the robot arm to pick-up object detected by the camera image and relocates it to a specified location on another test table. To pick-up the object the robot arm usually must have a gripper, but for this paper the gripper is being substituted with an electromagnet that can pick-up any metal object of weight approximately 100g max. A suitable command is needed inside the programming language to control the operation of the electromagnet. The object also must be placed very close to the electromagnet so that the magnetic force is sufficient to attract the metal object when the magnet is on.

MATERIALS AND METHODS

Equipments Description

The equipments used in implementing the integration of robot motion and vision for ASEA IRB 6 industrial robot consist of ASEA IRB 6 industrial robot, magnetic coil, indicator, ASEA control unit, supervising computer and a camera (See Figure 1).

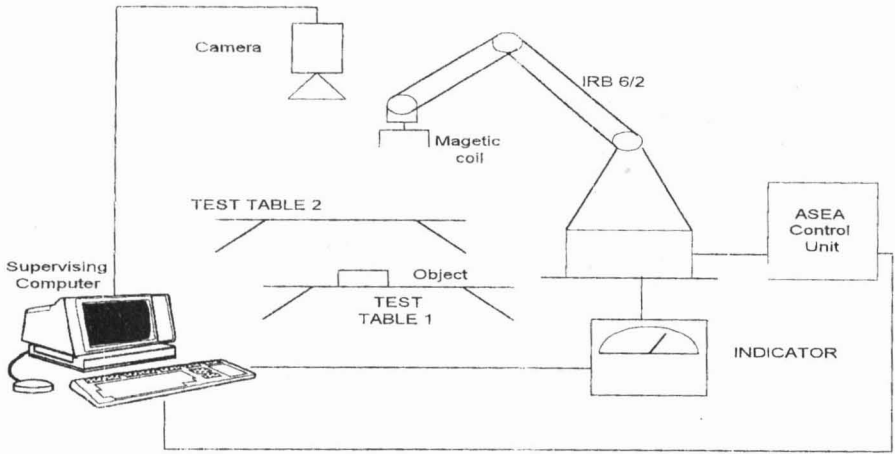

Figure 1: The Experimental Setup

The ASEA IRB 6 industrial robot is a five-axis robot. It can hold up to 6kg of load [ASEA 75] [1]. The motion of the robot arm is being controlled using the ASEA control unit. At the end of the robot arm, an electromagnetic coil (Refer Figure 2) is assembled to pick up the metal object (in this experiment the object is a black washer (See Figure 3)) on the test table.

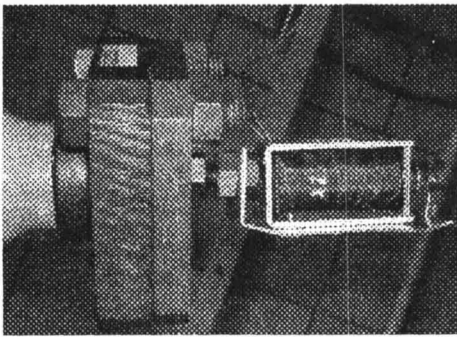

Figure 2 : The Magnetic Coil

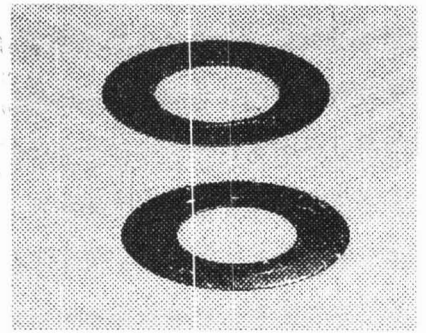

Figure 3: Black washer

The supervising computer is equipped with a Visual Basic 6.0 software as the programming language to program the motion of the robot arm. A camera *Baxall CD9752* is mounted on the beam above the test table to capture the image on the test table. The image of the camera can be viewed using the Visual basic interface (See Figure 4) on the supervising computer.

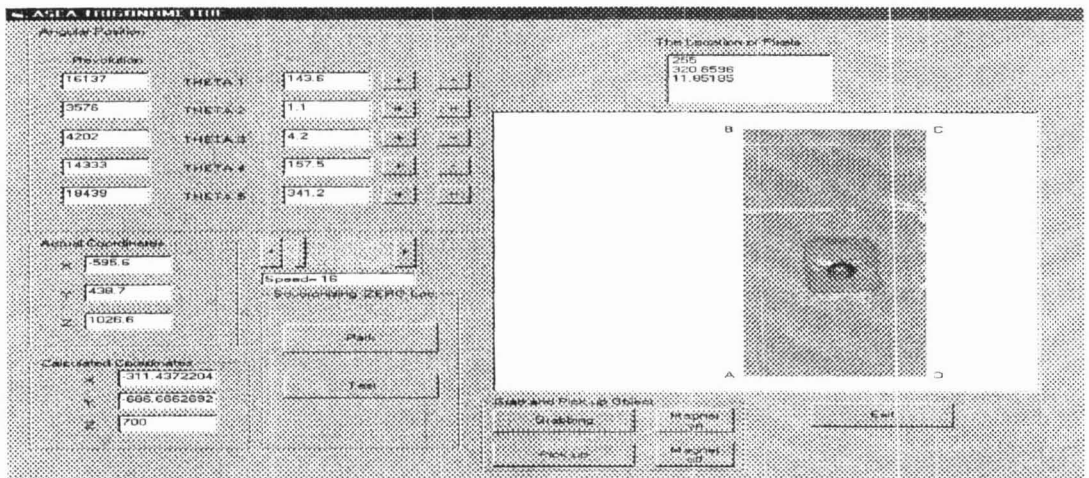

Figure 4. The Visual Basic user interface

Calibration of the camera

The camera was positioned directly above the test table. The aperture, focus and zoom were adjusted until the object image was sharply produced in the visual interface. Lines were drawn on a sheet of white paper, which was placed on the test table (Fung, et.al, 1988) [2]. When the program runs, the mouse pointer is positioned on a certain point on the lines drawn in the image of the camera to find the relationship between the camera pixels and the actual coordinates of the point using the Cartesian coordinates (x,y and z). Using this point a constant C_1 were found and stored to relate the camera pixels and the Cartesian coordinates.

By referring to a specific point in the image of the camera the relationship between the robot reference axis (x and y) and the point on the image is given by:

$$x = x_2 \times \frac{\cos(\theta_2 - C_2)}{\cos \theta_2} \dots\dots(1) \quad \text{and} \quad y = y_2 \times \frac{\sin(\theta_2 - C_2)}{\sin \theta_2} \dots\dots(2)$$

where

θ_2 is the angle of the specified point from the x_2 -axis

$$x_2 = C_1 p_j + C_3$$

$$y_2 = C_1 p_i + C_4 \quad \text{and} \quad C_2, C_3, C_4 \text{ are constants.}$$

The Kinematics of the ASEA IRB 6

The inverse kinematics for the ASEA IRB 6 can be solved using two different methods. The first method is by solving the kinematics using the trigonometric solutions. This method is easier since one can visualize the movement of each of the axis easily. The second method is by solving the kinematics using the DH-Parameters (McKerrow, 1991) [3]. In this method a homogenous transformation matrix is formed using the DH-Parameters to solve the rotation of each of the axis to achieve a specified point on the image of the camera.

The Inverse Kinematics Using The Trigonometric Solution

By referring to a specified point on the camera, the movement of each of the axis for the robot arm to reach the point can be solved using the Trigonometric solution. Using this method the axis of the ASEA IRB 6 can be visualized as shown in Figure 5.

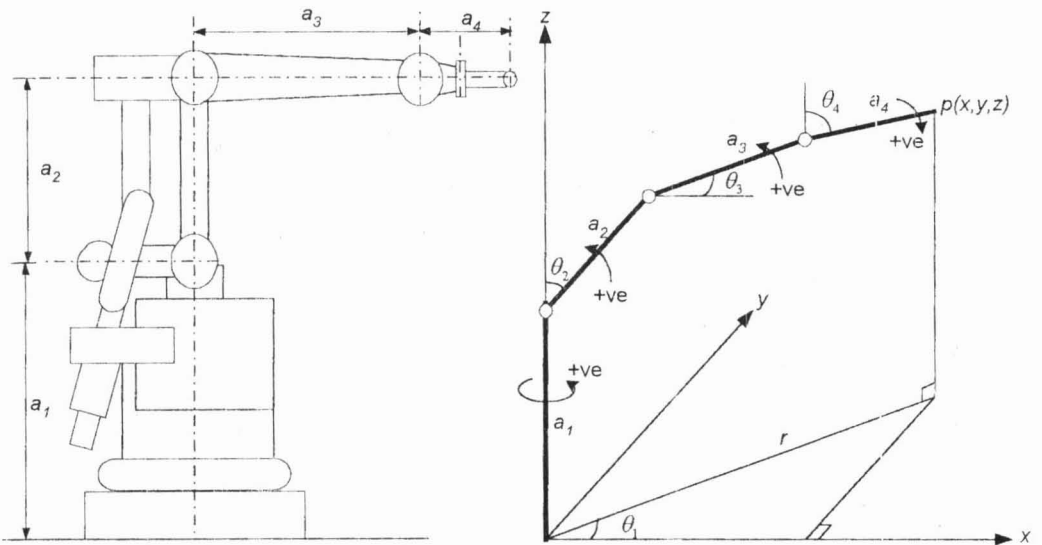

Figure 5: The Axis Of ASEA IRB 6 Using Trigonometric Solution

Referring to Figure 5 we can develop the relationship between x and y axis with $\theta_1, \theta_2, \theta_3$ and θ_4 as below:

$$x = r \cos \theta_1 \dots(3) \quad \text{and} \quad y = r \sin \theta_1 \dots\dots(4)$$

where : $r = a_2 \sin(-\theta_2) + a_3 \sin \theta_3 + a_4 \cos \theta_4$ and,

$$z = a_1 + a_2 \cos(-\theta_2) + a_3 \sin \theta_3 + a_4 \cos \theta_4 \dots\dots(5)$$

Note that the value of θ_2 is negative since the direction of rotation of the second axis of the robot arm is counter clockwise.

When we specify the location in the image (i.e. the coordinates of x,y and z are given) the movement of each of the axis can be specified by solving the inverse kinematics of the ASEA IRB 6. For the inverse kinematics we can simplify the axis of the robot arm from Figure 6 to Figure 7 by excluding the first axis. The reason is that the first axis is always in a vertical line and only moves in θ_1 direction.

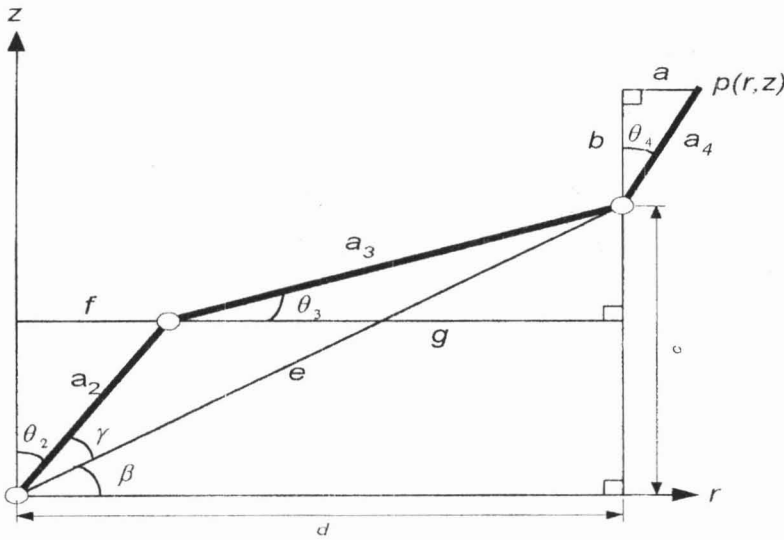

Figure 6: Simplified Diagram For Rotation Of The Robot Arm

From equation 3 and 4 we can derive the formula for θ_1 . Therefore :

$$\theta_1 = \tan^{-1}\left(\frac{y}{x}\right) \quad (6)$$

In the inverse kinematics the value of r can be calculated using the formula below:

$$r = \sqrt{x^2 + y^2} \quad (7)$$

Given that we know the value of θ_4 , by referring to Figure 6 we can find the values of θ_2 and θ_3 by solving the equations below:

$$a = a_4 \sin \theta_4 ; b = a_4 \cos \theta_4 ; c = z - b ; d = r - a ; e = \sqrt{c^2 + d^2} ; \beta = \cos^{-1}\left(\frac{d}{e}\right)$$

$$a_3^2 = a_2^2 + e^2 - 2a_2e \cos \gamma \Rightarrow \gamma = \cos^{-1}\left(\frac{a_2^2 + e^2 - a_3^2}{2a_2e}\right) \dots\dots(8)$$

$$\theta_2 = 90 - \beta - \gamma \dots\dots(9) \quad ; f = a_2 \sin \theta_2 ; \quad g = d - f ;$$

$$\theta_3 = \cos^{-1}\left(\frac{g}{a_3}\right) \dots\dots(10)$$

Using the trigonometric solution we can find the values of $\theta_1, \theta_2, \theta_3$ using equations 6,9 and 10 respectively.

RESULTS AND DISCUSSIONS

In order to determine whether the program runs correctly and the formula used using the two methods are correct, seven random points have been selected in the active camera image. Graphs are then drawn to establish the comparison between the calculated coordinates of the end-effector with the actual coordinates of the end-effector of the robot arms.

The differences between the calculated and actual coordinates are shown in the graphs:

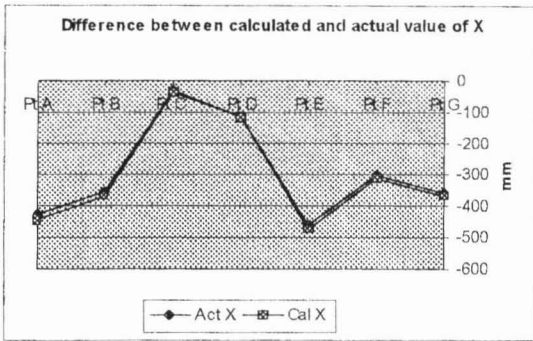

Graph 1a

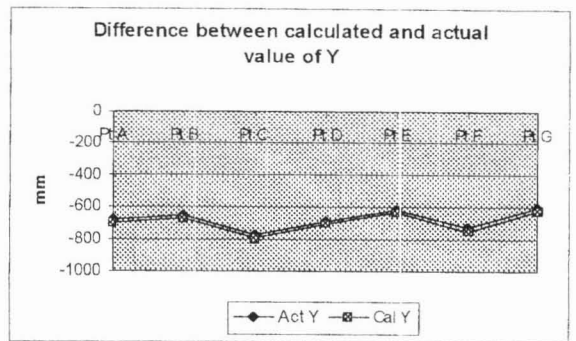

Graph 1b

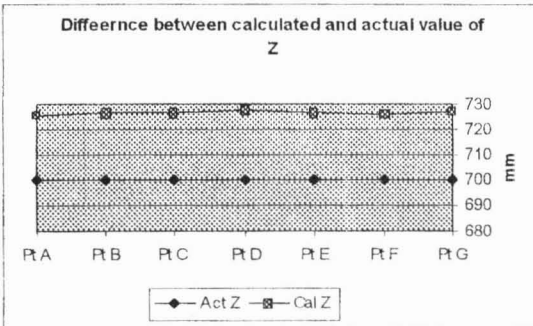

Graph 1c

From the results of the experiments it is shown that the program is able to move the robot arm to a specific location selected from the view given by the camera. From the results shown it is important to take into account the resultant error (± 5.0 mm) in calibration of the camera itself that results in the inaccuracy of the calculated point compared with the actual point of the end-effector.

As for the future work, the next phase of this experiment is to make the robot arm to pick-up an object on a moving conveyor belt. It will involve the image of the camera and the speed of the conveyor belt whereby when the object appears in the image of the camera, the program should automatically calculate the location of the object with respect to the base origin of the robot arm. The program should then perform the inverse kinematics and instruct the robot arm to pick the moving object.

REFERENCES

1. ASEA (1975). Programming and Operating ASEA's Industrial Robots. ASEA.
2. Fung, H. K., Leung, T.P., Lee, T. W. 1988. Planar Vision System For Object Recognition And Robot Control. Pineridge Ltd.
3. McKerrow, Philip John 1991. *Introduction to Robotics*. Addison-Wesley Publishing Company.