

KINETIC STUDY OF MONO- AND DISACCHARIDES BY SURFACE PLASMON RESONANCE OPTICAL SENSOR

Wan Yusmawati Wan Yusoff, W. Mahmood Mat Yunus and Zainal Abidin Talib
Applied Optics Laboratory, Department of Physics
Faculty Science and Environmental Studies
Universiti Putra Malaysia, 43400 Serdang, Selangor

Abstract: In this study, the Kretschmann surface plasmon resonance (SPR) technique is used to investigate the optical properties and kinetic behavior of mono- and disaccharide molecules to the gold surface. Two types of saccharides that are mono- and disaccharides (glucose, maltose and sucrose) in water at different level of concentration have been used in the angle scan SPR measurements. All measurements were carried out at room temperature with He-Ne laser (632.8nm, 5mW) was used as a light source. When the medium outside metal (gold) films is changed from air to saccharide solutions, the resonance angle shifted to the higher values. The shifts of resonance angle ($\Delta\theta_{SPP}$) increased linearly with the saccharides concentration in which the detection limit and detection sensitivity could be quantified. The sensitivity of the detection was $4.68^\circ/(\text{mol/l})$, $7.40^\circ/(\text{mol/l})$ and $9.42^\circ/(\text{mol/l})$ for glucose, maltose and sucrose, respectively. In addition, the detection limit of this optical sensor was estimated to be better than 0.005mol/l for those three saccharide solutions. The shift of resonance angle ($\Delta\theta_{SPP}$) increased rapidly with time for the first 200 minutes before it reached a constant value. It is noticed that the disaccharide molecules give response 30% better than monosaccharide molecules.

INTRODUCTION

Carbohydrates are organic compounds that consist of carbon, hydrogen and oxygen. It is divided into broad groups that are sugar and polysaccharide. Sugars are classified as monosaccharide and disaccharide, which is the important source of energy for human and animal. In this paper, mono- and disaccharide (glucose, maltose and sucrose) were chosen to be investigated for effective optical sensor based on surface plasmon resonance technique. The same sample was also used to study the kinetic behavior of their molecular in responding to the gold surface. Empirical formula of monosaccharide is $(\text{CH}_2\text{O})_n$ and range in size from trioses ($n = 3$) to heptoses ($n = 7$). Disaccharides are made up of two monosaccharides joined together (hence *di*-saccharide). Glucose ($\text{C}_6\text{H}_{12}\text{O}_6$) is a monosaccharide containing six carbon atoms. Glucose is an aldehyde (contain a $-\text{CHO}$ group). Five of the carbons, plus an oxygen atom, form a loop called a *pyranose ring*, the most stable form for aldoses. In this ring, each carbon is linked to hydroxide and hydrogen side groups with the exception of the fifth atom which link to a 6th carbon atom outside the ring, forming a group of CH_2OH . Maltose is *di*-glucose, two glucose molecules joined together through carbons one and four. This saccharide plays an important role in fermentation of alcohol by converting of starch sugar [1]. Sucrose is a disaccharide that yields 1 equivalence of glucose and 1 equivalence of fructose on acidic hydrolysis. It comes mostly from sugar beets and sugar cane. Figure 1 shows the structure of glucose, maltose and sucrose by Haworth formulae [2].

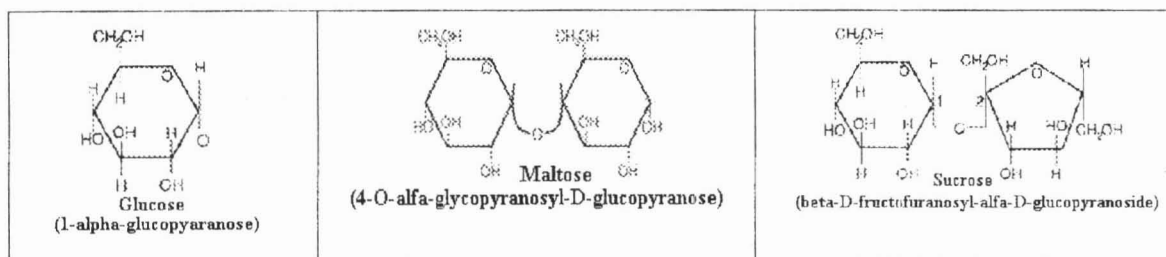

Figure 1: Chemical structure of glucose, maltose and sucrose (Haworth formulae)

For the last decade, surface plasmon resonance (SPR) sensors have been extensively studied [3]. SPR is a physical phenomenon that occurs when p-polarized light hits a metal film under total internal

reflection conditions [4]. Surface plasmon resonance technique has emerged as a powerful technique for a variety of chemical and biological sensor applications. The first application of SPR as a sensitive chemical sensing was successfully demonstrated by Liedberg et al. in 1983 [5].

SPR is an optical process in which light satisfying a resonance condition excites a charge-density wave propagating along the interface between a metal and dielectric material by monochromatic and p-polarized light beam. The intensity of the reflected light is reduced at a specific incident angle producing a sharp shadow (called surface plasmon resonance angle) due to the resonance energy occurs between the incident beam and surface plasmon wave.

Surface plasmon resonance (SPR) is regarded as a simple optical technique for surface and interfacial studies [6] and shows the great potential for investigating biomolecules. SPR has also been used to study the interaction between DNA and DNA [7], antibiotic and bacteria [8] and this technique also can be applied for gas detection [5], refractive index of liquid measurement [9,10] and pesticide detection [11]. SPR can be regarded as a significantly useful tool for analyzing saccharides where saccharides solution commonly has a high refractive index [12]. Therefore, sucrose is commonly used as a testing for chemical SPR system as reported by Jorgenson and Yee [13]. However, the response of the SPR optical sensor to glucose solution has not been extensively reported by previous researcher [14].

MATERIALS AND METHODS

Measuring the reflected He-Ne laser beam (632.8nm, 5mW) as a function of incident angle has been carried out in the angle scan surface plasmon resonance measurement. The experimental setup consists of a He-Ne laser, an optical stage driven by a stepper motor with a resolution of 0.001° (Newport MM 3000), a light attenuator, a polarizer and an optical chopper (SR 540) as shown in Figure 2. The reflected beam was detected by a sensitive photodiode and the signal was recorded and processed by a lock-in-amplifier (SR 530). The samples were prepared by systematically adding right amounts of sugar (mono- and disaccharide) to distilled water to produce solution concentrations of 0.02, 0.04, 0.06, 0.08 and 0.1 mol/l.

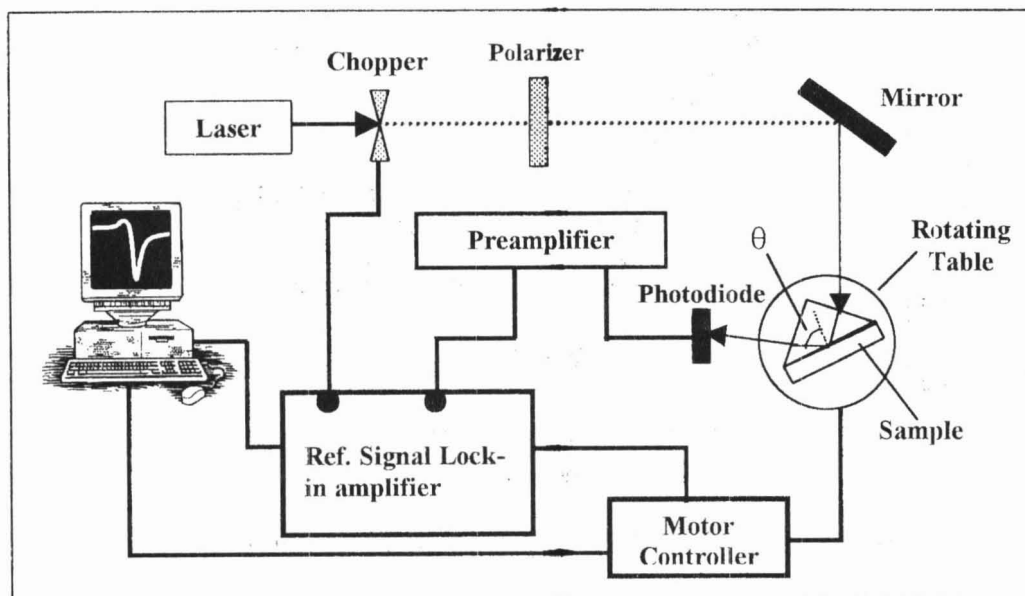

Figure 2: Experimental Setup for Kretschmann Surface Plasmon Resonance Technique

RESULTS AND DISCUSSIONS

Figure 3 shows the typical reflectance curve for gold-distilled water, gold-glucose, gold-maltose and gold-sucrose interfaces obtained at a concentration of 0.02 mol/L. It was observed that resonance angles changed from 41.22° (air) to 65.27° , 65.33° , 65.46° and 65.70° , for distilled water, glucose, maltose and sucrose solutions, respectively. These shifts of resonance angle were due to the difference in dielectric constant of the samples. Prior to the measurement, a preliminary test for distilled water has been done whereby the refractive index of distilled water obtained at 25°C was 1.330. This value is in agreement with the value reported by Webb et al. in 1989 [15]. When the solution of different concentration (mol/l) of reagent was used, the shift of reflectivity was also observed. The shift of resonance angle ($\Delta\theta_{\text{SPR}}$) increases with the increasing of the concentration (mol/l) of glucose, maltose and sucrose in water as shown in figure 4. Since the resolution of rotation angle is 0.001° , the detection limit of the sensor was estimated to be 0.003 mol/l , 0.002 mol/l , 0.001 mol/l for glucose, maltose and sucrose, respectively. However, the slope of the straight line that reflects the sensitivity of the detection was calculated to be $4.68^\circ/(\text{mol/l})$, $7.40^\circ/(\text{mol/l})$, $9.42^\circ/(\text{mol/l})$ for glucose, maltose, and sucrose in water. The detection sensitivity of maltose and sucrose are higher than glucose due higher the number of carbon atoms in maltose and sucrose molecules as previously reported [12]. From figure 4, a linear relationship shows that the resonance angle shift is directly proportional to the solution concentration. The linear regression coefficients for glucose, maltose and sucrose are 0.991, 0.994 and 0.994, respectively. These good linearity relationships obtained are similar to the results reported by Zhen and Yi [12] for glucose and sucrose solutions using multi-wavelength surface plasmon resonance (SPR) spectroscopy. By fitting the experimental data to the Fresnel equation [16,17], the value of real and imaginary part of dielectric constants, ϵ_r and ϵ_i as a function of concentration of three saccharide were obtained. Figure 5 shows the fitting line is in good agreement with the experimental data for maltose sample measured at 0.1 ml/l concentration. The experimental values of ϵ_r and ϵ_i for the samples studied in this work are linearly increasing with the increasing of solution concentration. The typical experimental values obtained for two concentrations (i.e. 0.08 ml/l and 0.10 ml/l) are listed in Table 1.

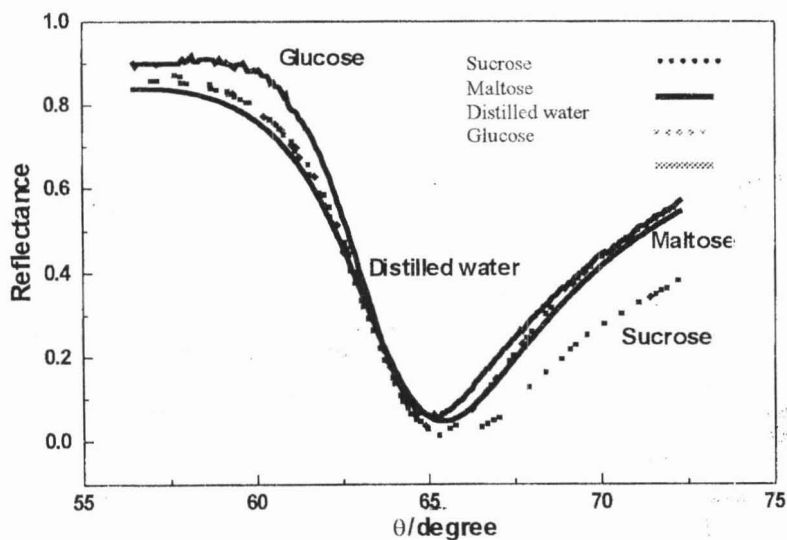

Figure 3: Reflectance curves for distilled water, glucose, maltose and sucrose at 0.02 mol/l.

The time dependence of the resonance angle shift for gold-glucose, gold-maltose and gold-sucrose interfaces at 0.1 mol/l concentration are shown in Figure 6. The increase in shift angle with time is greatly due to the increment of the molecule adsorbed to the gold surface. Again, the differences of those responses may be due to the different formula structure of saccharide. It shows that the maltose and sucrose respond faster and better than glucose. However, it takes about 200 minutes to reach a plateau region for all tested samples.

Further measurements were conducted using sucrose sample at three different concentration for studying the concentration effect on kinetic behavior of the saccharide molecules. Figure 7 shows the time dependence of the shift in resonance angle at three different concentrations of sucrose. At first, the shift of resonance angle increased exponentially before it reached a plateau region. It is found that resonance angle changes dramatically with the increasing concentration of sucrose in water. This phenomenon is related to the polarity of solution as described by Ping et al [18, 19].

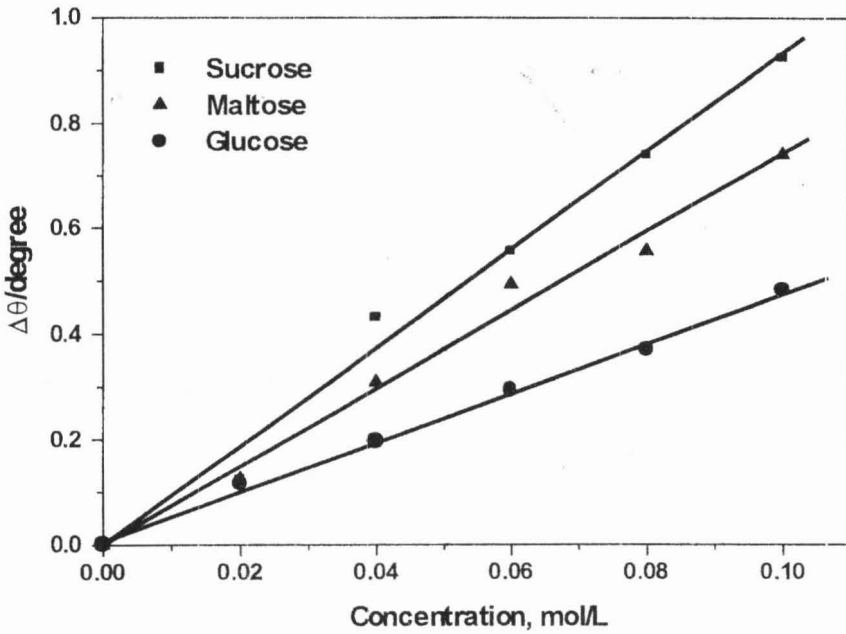

Figure 4: The shift of resonance angle versus glucose, maltose and sucrose concentration (mol/l)

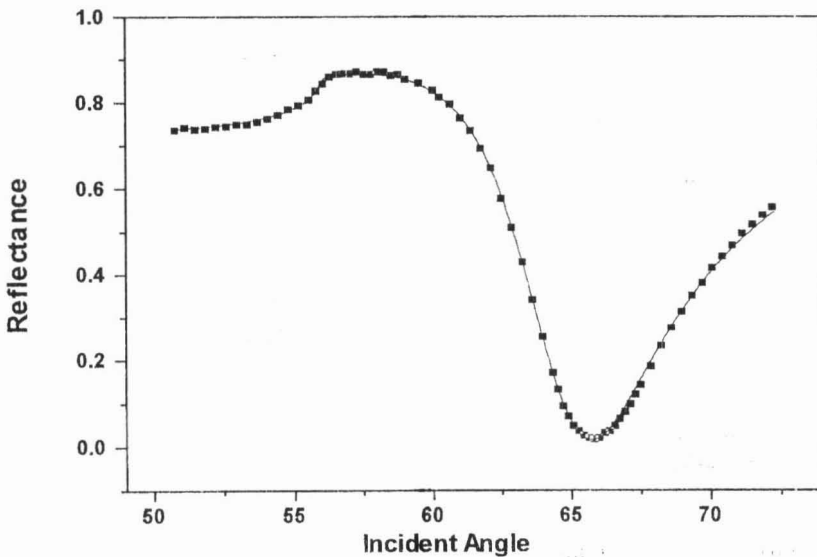

Figure 5: Optical Reflectance as a function of incident angle. The solid line represented a theoretical data

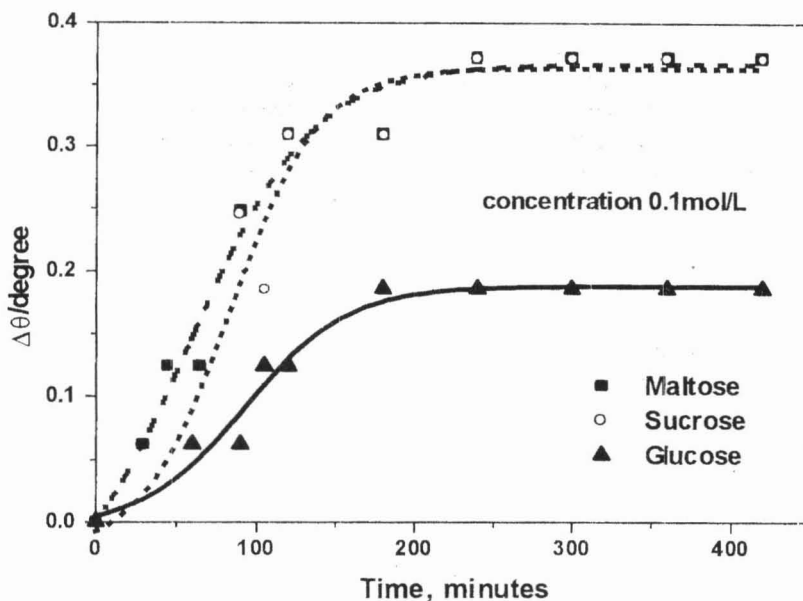

Figure 6: $\Delta\theta_{SPR}$ versus time for: glucose, maltose and sucrose.

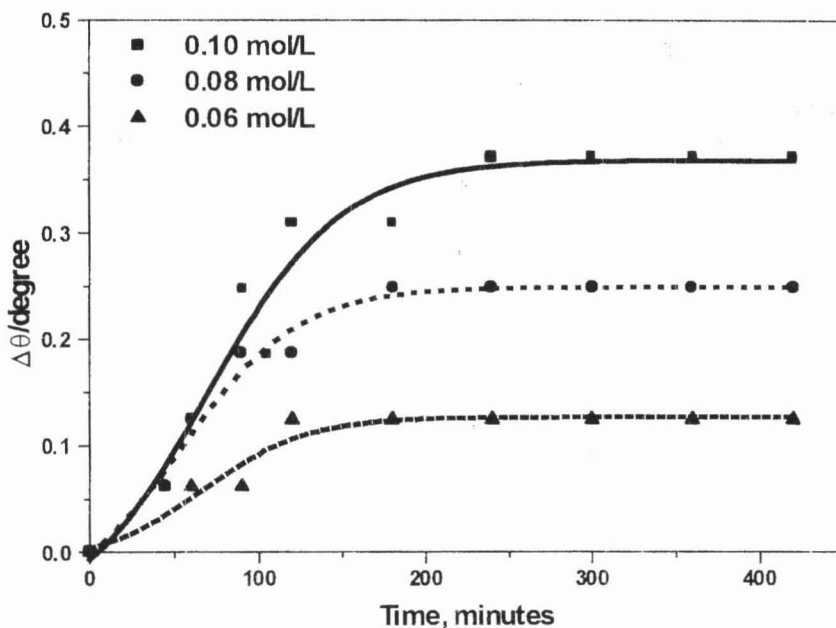

Figure 7: Graph the shift of resonance angle versus time at different concentration (mol/l) of sucrose solution

Table 1: The value of real and imaginary parts of dielectric constant ϵ_r and ϵ_i saccharide solutions at two different concentrations.

Concentration	0.08mol/l			0.10mol/l		
Sample	Glucose	Maltose	Sucrose	Glucose	Maltose	Sucrose
ϵ_r	1.7780	1.7851	1.7913	1.7834	1.7907	1.7984
ϵ_i	0.0100	0.0065	0.0215	0.0111	0.0095	0.0267

CONCLUSIONS

A simple optical sensor based on Kretschmann surface plasmon resonance has been tested for the detection of three saccharide solutions (glucose, maltose and sucrose) in water. The sensitivity of the detection was calculated to be $4.68^\circ/(\text{mol/l})$, $7.40^\circ/(\text{mol/l})$ and $9.42^\circ/(\text{mol/l})$ for glucose, maltose and sucrose in water, respectively. The detection limit of this sensor was estimated to be better than 0.005mol/l for those three saccharides (glucose, maltose and sucrose) in water. The shift of resonance angle ($\Delta\theta_{\text{SPP}}$) increase with time rapidly due to the adsorption of molecule deposited on the gold surface. It is observed that the disaccharide molecule gives better response than monosaccharide.

ACKNOWLEDGEMENTS

This research was fully financed by IPRA and PASCA (Wan Yusmawati Wan Yusoff) programs. The laboratory facilities provided by the Department of Physics are acknowledged.

REFERENCES

1. Rees, R.A. 1967. The shape of molecules carbohydrate polymers, Contemporary Science Paperbacks 14, London.
2. Ferrier, R.J. and Collins, P.M. 1972. Monosaccharide chemistry, Pergin, Britain.
3. Homola, J., Yee, S., and Gauglitz, G. 1999. Surface plasmon resonance sensors: review. *Sens. Actuators B* 544: 3-15
4. Davis, T. M. and Wilson, W. D. 2000. Determination of the refractive index increment of small molecules for correction of surface plasmon resonance data. *Anal. Biochemistry* 284: 348-353
5. Liedberg, B., Nylander, C., and Lundström, I. 1983. Surface plasmon resonance for gas detection and biosensing. *Sens. Actuators B* 4: 299-304
6. Salamon, Z., Macleod, H.A. and Tollin, G. 1997. Surface plasmon resonance spectroscopy as a tool for investigating the biological and biophysical properties of membrane protein system. I: Theoretical principles. *Biochem. Biophys. Acta* 131: 171-129
7. Kai E., Sawata, S., Ikeburuko, K., Iida T., Honda T. and Kabure I.1999. Detection of PCR products in solution using surface plasmon resonance. *Anal. Chem.* 71:796-800
8. Cooper, M. A. and William, D. H. 1999. Binding of glycopeptide antibiotics to a model of a vancomycin-resistant bacterium. *Chem. Biol.* 6:891-899
9. Matsuba, K., Kuwata, S., and Minami, S. 1988. Optical chemical sensor based on surface plasmon resonance measurement. *J. Appl. Opt.* 27: 1160-1163
10. Kano, H., and Kawata S.. 1995. Grating-coupled surface plasmon for measuring the refractive index of a liquid sample. *Jpn. J. Appl. Phys.* 34: 331-335
11. Chegal, V.I., Shirshov, Yu. M., Piletsky, S.A. 1998. Surface plasmon resonance sensor for pesticide detection. *Sens and Actuators B.* 48: 456-460
12. Zhen, W and Yi, C., 2001. Analysis of mono- and oligosaccharide by multiwavelength surface plasmon resonance (SPR) spectroscopy. *Carbohydrate Research* 332: 209-213
13. Jorgenson, R.C. and Yee, S., S. 1993. A fiber-optic chemical sensor based on surface plasmon resonance. *Sens. Actuators B* 12: 213-220

14. Yunus, W.M.M., Mokhtar, R., Moxsin, M.M, Peng, C. B. and Yeh, L., W. 2000. Optical sensor based on surface plasmon resonance measurement. *Asean J. on Science and Technology and Development* 17(2):31-38
15. Webb, D. J., Tatam, R. P. and Jackson, D. Q. 1989. A novel interferometric liquid refractometer. *Rev. Sci., Instrum.* 60(10):3347-3348
16. Sincerbox, G.T. and Gordon II, J.C. 1981. Small fast large-aperture light modulator using attenuated total reflection. *J. Appl. Opt.* 20:1491-1494
17. Lévesque, L., Paton, B.E., and Payne, S.H. 1994. Precise thickness and refractive index determination of Polyimide film using attenuated total reflection. *J. Appl. Opt.* 33:8036-8040
18. Namira, E., Hayashida, T. and Arakawa, T. 1995. Surface plasmon resonance study for the detection of some biomolecules. *Sens. Actuators B.* 24-25: 142-144
19. Ping Li, Yan Huang, Junze Hu, Chunwei Yuan and Baoping Lin. 2002. Surface plasmon resonance studies on molecular imprinting. *Sens.* 2: 35-40