

# Hybrid Fuzzy PID Controller Design for Ball and Beam system

Nur Sakinah Abdul Aziz, Norlela Ishak, Ramli Adnan, Mazidah Tajjudin

**Abstract**— This research was focusing on the design of fuzzy logic PI+PD controller for ball and beam system. PID controller is mostly used in industrial applications. However, PID controller is not always an efficient combination for every type of system application. Due to some weaknesses that have been realized in conventional PID controller in term of error elimination and overshoot problems, fuzzy PI+PD was proposed for the system being considered. This paper presents the performance gained from Fuzzy PI+PD controller compared to Fuzzy PID. Based on simulations, the proposed controller had shown better performance compared to the full composite PID controller.

**Index Terms**— Fuzzy logic control, PID controller, Fuzzy PID, Fuzzy PI+PD, Ball and beam.

## I. INTRODUCTION

Nowadays, there are many types of controller available in the market which can be categorized by the cost, design and functions [1]. However, based on recent development, all the categories are combined and considered to produce the best controller. There are also a few types of controller that are using Proportional (P), Integral (I) and derivative (D) control system. Despite of technological advancement, PID is still considered as the best control structure for most industrial applications. PID controller can be tuned according to one's need regardless of the method of tuning [2][3]. The basic equation of the conventional PID is;

$$u(t) = K_p e(t) + K_i \int_0^t e(t) + K_d \frac{d}{dt} e(t) \quad (1)$$

PID is preferred because of its simplicity and flexibility. Moreover, PID controller can guarantee the stability and reliability as they can be precise depending on the mathematical models of the process under controlled. However, the PID itself does not enough to support more complex machines, especially when the system is nonlinear. Therefore, the usage of the PID controller can be extended by adding Fuzzy Logic [3].

This manuscript is submitted on 18<sup>th</sup> March 2019 and accepted on 13<sup>th</sup> September 2019. Nur Sakinah is a postgraduate student at Graduate Office of Electrical Engineering. Norlela Ishak, Ramli Adnan and Mazidah Tajjudin are from Faculty of Electrical Engineering, Universiti Teknologi MARA, 40450 Shah Alam, Selangor, Malaysia. (e-mail:mazidah@uitm.edu.my).

Many have known the limitation of PID controller is to find its optimal gain so, by adding fuzzy logic this issue can be resolved. Fuzzy Logic is applicable for both non-linear and complex system. The algorithm uses a set of linguistic rules for determining the control action where it is based on human logical thinking. In terms of error, fuzzy logic is also capable to reduce the overall error compared to PID alone [4]. Besides that, fuzzy logic controller has high robustness and researchers always seek for the use of Fuzzy to help improving the performance of complex machines [5]. Fuzzy controller is functioning by using human knowledge where this leads to control design based on fuzzy rule. These rules were created based on relationship between input and output variables. However, depending on application, a full combination of Fuzzy PID is not always necessary.

Many combinations of Fuzzy PID had been tested such as fuzzy P+ID, fuzzy PI+PD and fuzzy PI+D [6]. This approach not only makes response time faster, but the complexity of the controller design also can be reduced. For example, in research by A. I. Isa et.al [7], the hybrid Fuzzy had been applied and compared with conventional PID controller on ball and beam system. The combination of hybrid Fuzzy is tends to focus on improving the transient response. From the simulation, the result shows that hybrid Fuzzy had better performance and robust to disturbance compared to conventional PID controller. The same technique was applied on speed control for brushless DC motor [8]. The result shows that hybrid fuzzy controller can perform well in transient response.

This research focuses on the design of Fuzzy PI+PD controller on ball and beam system. The same criteria performance had discussed in [7] but for this research the fuzzy controller focusses on PI controller. The main objective of this research is to evaluate and analyze the performance gained from Fuzzy PI+PD. The results of fuzzy PI+PD were compared with conventional PID and Fuzzy PID. This paper is prepared as follows; part II explained on plant model of ball and beam system while part III about design of Fuzzy PI+ PD. The simulation result and discussion are discussed in part IV. Lastly, conclusion for this research is made in part V.

## II. BALL AND BEAM MODEL

Schematic diagram of ball and beam system is shown in Fig. 1. The length of the beam is  $L$ . It can be related to the inclination angle of the beam,  $\alpha$ , radius  $d$  and gear angle  $\theta$  by (1).

$$\alpha = \frac{d}{L} \theta \quad (1)$$

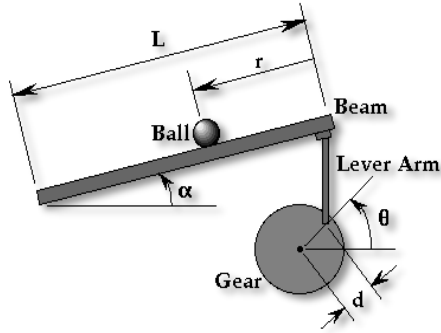

Fig.1.The relation between motor position and beam angle

Based on Fig 1, the Lagrangian equation of motion for ball and beam can be written as:

$$\left(\frac{J}{R^2} + m\right) \ddot{x} + mg \sin \alpha - m x (\dot{\alpha})^2 = 0 \quad (2)$$

If the beam angle  $\alpha = 0$ , then linear approximation of the system becomes:

$$\left(\frac{J}{R^2} + m\right) \ddot{x} = -mg\alpha \quad (3)$$

Then, substituting (1) in (3),

$$\left(\frac{J}{R^2} + m\right) \ddot{x} = -mg \frac{d}{L} \theta \quad (4)$$

Taking Laplace transform of (4),

$$\begin{aligned} \left(\frac{J}{R^2} + m\right) X(s) s^2 &= -mg \frac{d}{L} \theta(s) \\ \frac{X(s)}{\theta(s)} &= \frac{-mgd}{L s^2 \left(\frac{J}{R^2} + m\right)} \end{aligned} \quad (5)$$

The derivation above was applied by Krishna in his research. The dynamic of the ball is related to gravity, rotational inertial centrifugal force and so on. All the data specifications of the ball and beam applied in this research are listed in Table I [10].

Table I: Specifications of Ball and Beam system

Specification's name	Unit	Value
Mass of the ball (m)	Kg	0.011
Radius of the ball(R)	m	0.015
Acceleration due to gravity (g)	m/s <sup>2</sup>	-9.8
Length of the beam (L)	m	0.4
Radius of the gear (d)	m	0.1059
Ball moment of inertia (J)	2*m*R <sup>2</sup> /5	-

From Table I, the ball and beam system transfer function can be represented by (6):

$$\begin{aligned} \frac{r(s)}{\theta(s)} &= \frac{-(0.011)(-9.8)(0.1059)}{0.4 \left(\frac{2 \times 0.011}{5} + 0.011\right) s^2} \\ r(s) &= \frac{1.853}{s^2} \end{aligned} \quad (6)$$

### III. DESIGN OF FUZZY PID

The proposed design of Fuzzy PI+PD is done by using MATLAB Simulink. Fig. 2 shows the block diagram of Fuzzy PI+PD controller. The block diagram contains Fuzzy Logic controller with Ruleviewer block to adjust the gain of P and I. The output from Fuzzy Logic controller will acts as input for PI controller.

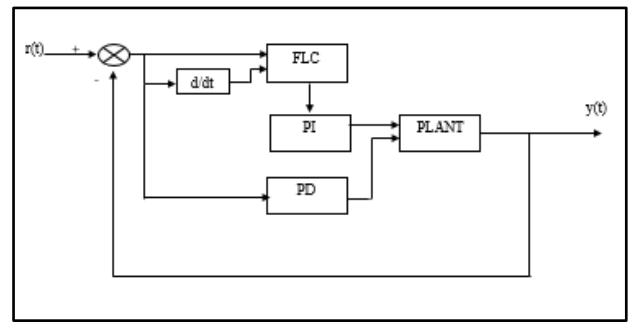

Fig.2.The proposed fuzzy PI+ID structure.

The fuzzification process of two inputs will produce the output of the fuzzy logic controller depending on the membership function designed [11][12]. The input signal will be converted into fuzzy number in fuzzifier for each sampling to the Fuzzy Logic controller. The important elements that are being concerned in the designs of FLC are described in next sections.

#### A. Membership Function

The membership function is defined as the mapping of the points within input space to a degree of membership. The inputs are the error (e) and rate of error (re), while the output is the controller gain (Cl) [12].

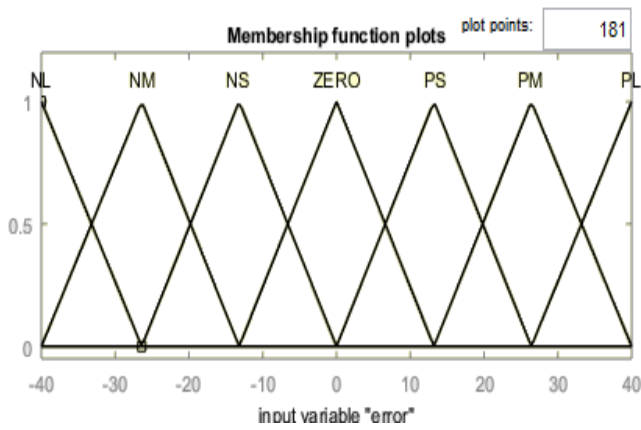

Fig.3. Membership Function for Error

Fig. 3 shows the membership function of the error with the range of -40 to 40. This range is selected based on the full range of the beam and the range is divided into seven membership functions with each of them assigned to their own linguistic variable.

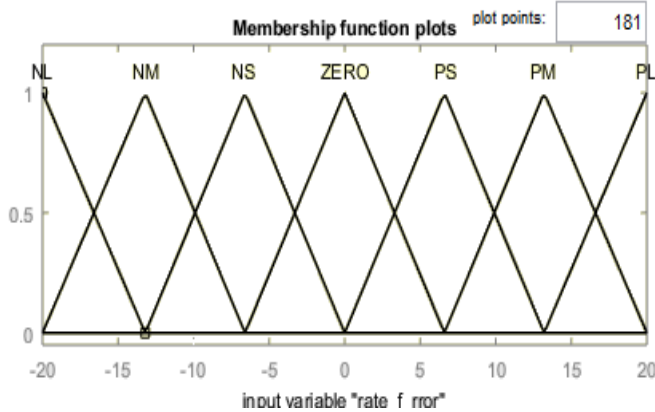

Fig.4. Membership Function for Rate of Error

The membership of rate of error is shown in Fig 4. The range of membership functions for error rate is between -20 to 20. The range is selected to reduce disturbance that mostly occur in positioning the ball control.

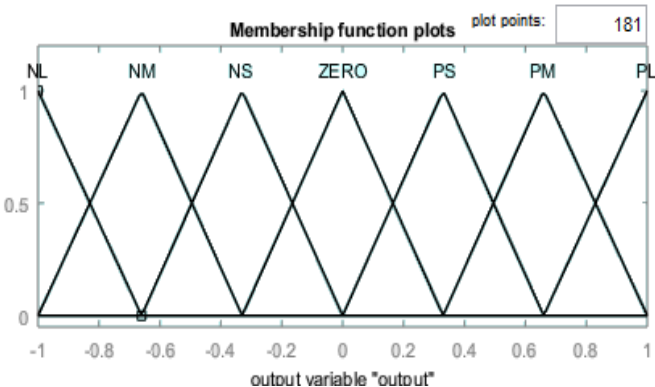

Fig.5. Membership Function for Output

The output of the controller was demonstrated in Fig.5 which is membership function of the controller output. The range was normalized within -1 to 1 and then multiplied with the range of PID parameters for their actual controller gain.

Table II. The Variables of Membership Function

Linguistic Variables	Definition
NB	Negative Big
NM	Negative Medium
NS	Negative Small
Z	Zero
PS	Positive Small
PM	Positive Medium
PB	Positive Big

In this research, 7 membership functions were created. The membership functions were defined as Negative Big (NB), Negative Medium (NM), Negative Small (NS), Zero (Z), Positive Small (PS), Positive Medium (PM) and Positive Big (PB). The membership function that are used is the triangular trimf type where the in and out variables of membership function are shown in Table II.

**B. Fuzzy Rules**

Fuzzy rules is defined as a conditional statement in the form of: If  $e=A$  and  $re=B$ , then  $Cl=C$ ; A and B are linguistic values determined by fuzzy sets on the error and rate of error respectively [8]. These linguistic variables mapped the input and output via the fuzzy mapping rules, and the function is same with human instinct and decision making capability. The fuzzy logic that has been proposed will produced a total of 49 fuzzy rules. Table III shows the designed fuzzy rules.

Table III. Fuzzy Rules

Rate of error	Error						
	NB	NM	NS	ZERO	PS	PM	PB
NB	NB	NB	NB	NM	NS	NS	ZERO
NM	NB	NM	NM	NM	NS	ZERO	PS
NS	NB	NM	NS	NS	ZERO	PS	PM
ZERO	NB	NM	NS	ZERO	PS	PM	PB
PS	NM	NS	ZERO	PS	PS	PM	PB
PM	NS	ZERO	PS	PM	PM	PM	PB
PB	ZERO	PS	PS	PM	PB	PB	PB

**IV. SIMULATION RESULTS AND DISCUSSION**

The results have been discussed in two sections which are the performance of the controller under step test and while tracking a pulse and sinewave signals.

**A. Step Response Evaluation**

The PID controller is tuned by using PID Auto-tune Toolbox in MATLAB Simulink. All gain parameters were recorded as follows:

$$K_p = 0.390$$

$$K_i = 0.022$$

$$K_d = 0.980$$

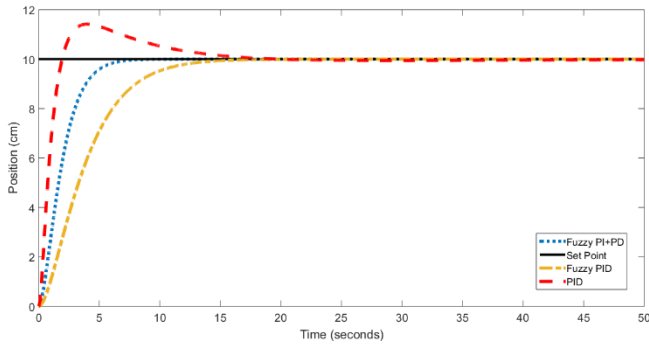

Fig.6. Step Response for PID, fuzzy PID and Fuzzy PI+PD Controller

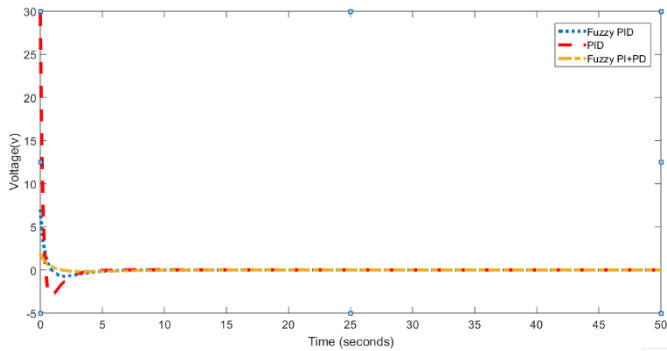

Fig.7. Control signal of PID, fuzzy PID and Fuzzy PI+PD Controller

Table IV. Step Response Values

Structures	Parameters		
	Rise Time (Seconds)	Settling Time (Seconds)	Overshoot (Percent)
PID	1.314	14.33	14.368
Fuzzy PID	6.927	11.95	0
Fuzzy PI+PD	3.346	5.749	0

From the results, it is obvious that the rise time, settling time and overshoot for the proposed design is better compared to other controllers where the rise time is 3.346 seconds and 5.749 seconds for settling time. Thus, for overall evaluation, the proposed design, Fuzzy PI+PD controller was the best controller for the steady-state error reduction, overshoot elimination and had the fastest transient.

**B. Tracking Performance Evaluation**

This section provides the tracking performance for three controllers using two different inputs which are pulse and sinewave. Both input used the same frequency which is 0.02 Hz and the amplitude of 5cm.

The range of frequency that is suitable is from 0.02 until 0.1 Hz. If the frequency used is outside of the range, the output response will not track the input perfectly and it will produce significant value of error. Fig. 8 and Fig. 9 below shows that the output response of PID, fuzzy PID and fuzzy PI+PD in sinewave and pulse.

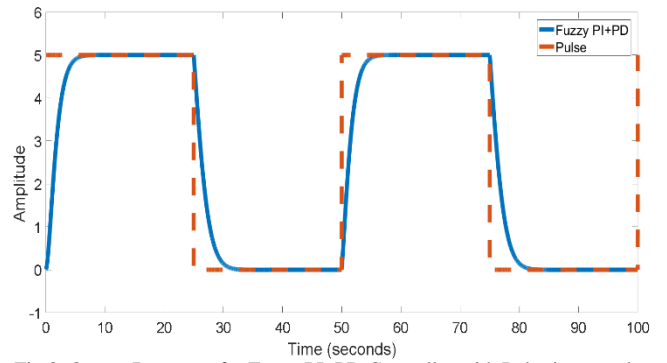

Fig.8. Output Response for Fuzzy PI+PD Controller with Pulse input and frequency of 0.02 Hz

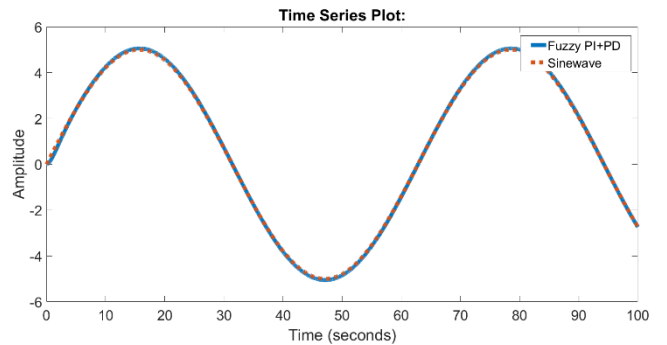

Fig.9. Output Response for Fuzzy PI+PD Controller with Sinewave input and frequency of 0.02 Hz.

Table V. ISE and IAE Values for Pulse and Sinewave Input Tracking

Controller	Frequency (Hz)	Input	ISE	IAE
PID	0.02	Sinewave	0.30	4.60
		Pulse	207.60	74.80
	0.05	Sinewave	0.28	4.14
		Pulse	504.80	185.40
	0.1	Sinewave	16.24	36.19
		Pulse	817.10	415.10
Fuzzy PID	0.02	Sinewave	3.80	17.40
		Pulse	96.70	33.10
	0.05	Sinewave	0.04	1.27
		Pulse	231.30	80.58
	0.1	Sinewave	0.92	8.46
		Pulse	444.30	156.50
Fuzzy PI+PD	0.02	Sinewave	0.20	3.83
		Pulse	29.1	18.60
	0.05	Sinewave	0.03	1.15
		Pulse	73.39	45.43
	0.1	Sinewave	1.52	11.02
		Pulse	159.10	80.20

Table V shows the value of ISE and IAE for PID, Fuzzy PID and Fuzzy PI+PD while tracking the pulse and sine input with different frequencies range from 0.02 Hz, 0.05 Hz and 0.1 Hz.

At the frequency of 0.02 Hz, the value of ISE and IAE for PID are 0.30 and 4.60 for sine wave while 207.60 and 74.80 for pulse generator.

For the Fuzzy PID, the sine wave concluded value of 3.80 and 17.40 for sine wave and 96.70 and 33.10 for pulse generator. The best controller for this frequency would be Fuzzy PI+PD where the values of ISE and IAE for sine wave are 0.20 and 3.83 and for pulse generator are 29.10 and 18.60.

At the frequency of 0.05 Hz, the values of ISE and IAE for sine wave and pulse generator for the conventional PID are as follow; 0.28, 4.14, 504.80, 185.40 respectively. As to the Fuzzy PID, the values are 0.04, 1.27 and 231.30, 80.58 respectively. However, at this frequency, the best values of ISE and IAE are 0.03, 1.15 and 73.39, 45.43 for the Fuzzy PI+PD controller.

Frequency of 0.1 Hz, the conventional PID, the values of ISE and IAE for sine wave are 16.24 and 36.19 respectively and 817.10 and 415.10 respectively for the pulse generator. However, for the Fuzzy PID, the values for sine wave are 0.92 and 8.46 respectively and for the pulse generator are 444.30 and 156.50. Lastly, the values of ISE and IAE for the Fuzzy PI+PD are 1.52 and 11.02 respectively for the sine wave input and 159.10 and 80.20 respectively for the pulse generator input.

#### V. CONCLUSION

This paper compares the performance between three types of PID controller which were basically the improvisation from a conventional PID controller to a more complexed fuzzy PI+PD controller. This research have been succeeded in eliminating the error by evaluate and analyze the performance gained from PID, Fuzzy PID and Fuzzy PI+PD controller system. Then all of these controllers have been tested using different input which is pulse and sinewave. All the simulation for the controllers has been done using MATLAB Simulink.

#### ACKNOWLEDGMENT

This research is financially supported by Faculty of Electrical Engineering students' fund. The authors would like to thank the Faculty of Electrical Engineering, UiTM Malaysia for facilities provided during this research. We also would like to express our gratitude to Institute of Research Management & Innovation (IRMI) UiTM and all members of PICon Research Interest Group for their comment and support.

#### REFERENCES

- [1] R. Shakya, K. Rajanwal, S. Patel, and S. Dinkar, "Design and Simulation of PD, PID and Fuzzy Logic Controller for Industrial Application," vol. 4, no. 4, pp. 363–368, 2014.
- [2] Y. H. Putra, "Tuning Methods of PID Controller," pp. 1–24, 2009.
- [3] E. baniwalid, "Fuzzy Control For Nonlinearball," vol. 3, no. 1, 2013.
- [4] N. S. A. Aziz, R. Adnan, and M. Tajjudin, "Design and evaluation of fuzzy PID controller for ball and beam system," *2017 IEEE 8th Control Syst. Grad. Res. Colloquium, ICSGRC 2017 - Proc.*, pp. 28–32, 2017.
- [5] M. D. Schrieber and M. Biglarbegian, "Hardware implementation and performance comparison of interval type-2 fuzzy logic controllers for real-time applications," *Appl. Soft Comput. J.*, vol. 32, pp. 175–188, 2015.
- [6] M. V Burakov and V. G. Kurbanov, "Fuzzy pid controller for nonlinear plant 1," vol. 11, no. 9, pp. 5745–5748, 2016.
- [7] A. I. Isa, M. F. Hamza, A. Y. Zimit, and J. K. Adamu, "Modelling and fuzzy control of ball and beam system," *IEEE Int. Conf. Adapt. Sci. Technol. ICAST*, vol. 2018–August, pp. 1–6, 2018.
- [8] N. Tiwary, A. Rathinam, and S. Ajitha, "Design of hybrid Fuzzy-PI controller for speed control of Brushless DC motor," *Int. Conf. Electron. Commun. Instrum. 2014, ICECI 2014*, 2014.
- [9] A. I. Isa, "Modelling and Fuzzy Control of Ball and Beam System."
- [10] Googol Technology, "Ball & Beam Control System," pp. 1–5, 2013.
- [11] S. K. Oh, H. J. Jang, and W. Pedrycz, "The design of a fuzzy cascade controller for ball and beam system: A study in optimization with the use of parallel genetic algorithms," *Eng. Appl. Artif. Intell.*, vol. 22, no. 2, pp. 261–271, 2009.
- [12] H. Wahid, M. Fua, and A. D. Rahmat, "A STUDY OF DIFFERENT CONTROLLER STRATEGIES FOR A BALL AND BEAM SYSTEM," vol. 50, no. D, pp. 93–108, 2009.