

Energy Production using Solar-powered Electrolyzer and Hydrogen Fuel Cell

Teoh Wei Hern¹, Samihah Abdullah², Shabinar Abdul Hamid² and Solahuddin Yusuf Fadhlullah^{1,*}

¹*School of Engineering and Technology, INTI International College Penang, Z-1, Lebuh Bukit Jambul, Bukit Jambul, 11900 Bayan Lepas, Pulau Pinang, Malaysia*

²*Faculty of Electrical Engineering, Universiti Teknologi Mara Pulau Pinang, 13500 Permatang Pauh, Pulau Pinang, Malaysia*

*corresponding author: solah.fadhlullah@newinti.edu.my

ARTICLE HISTORY

ABSTRACT

Received
27 Mei 2019

Accepted
7 June 2019

Available online
30 June 2019

This study presented the implementation of a small-scale (50 W) solar energy harvesting system coupled with an electrolyzer and proton exchange membrane (PEM) fuel cell. The energy from the solar panel would be utilized by the electrolyzer to produce hydrogen gas. The hydrogen gas would be used, in turn, by the PEM fuel cell to generate electricity which supports both DC and AC load. Excess energy from the solar panel is also used to charge the lead-acid backup battery. Analysis of the system showed that 400 mL of hydrogen gas could be produced within every 17 minutes in optimal conditions; between 11 am until 4 pm with bright sunlight. For every 400 mL of hydrogen gas, the PEM fuel cell could sustain continuous operation of a 5V 500 mA DC load for 95 seconds. Theoretically, more than 7000 mL of hydrogen gas could be produced within 5 hours in strong sunlight, which could power up a 50 mA and 500 mA load for 4.7 hours and 28 minutes respectively, during evening or night operations. The proposed system could complement the traditional battery-based storage system while remaining as a clean source of energy production.

Keywords: Proton exchange membrane fuel cell; PEM fuel cell; solar energy harvesting; hybrid electrolyzer and PEM fuel cell; power management unit; hydrogen gas

1. INTRODUCTION

In a typical small-scale setup, a solar panel combined with a power management unit and a backup battery would provide power throughout the day and night. Features such as maximum power point tracker (MPPT), solar tracker and ‘matching solar panel-battery power ratings’ are implemented to increase energy production and efficiency. To further consolidate energy production and storage, the fuel cell system is introduced to complement the traditional solar energy harvesting system.

In conventional settings, during the daytime, electrical energy generated from the solar panel is either directly stored into rechargeable batteries or used in conjunction with a load, where excess energy is then stored into the battery. At night, the system would rely on the battery to continue to operate the load and the process repeats the next day.

The commonly used lead-acid battery is still considered hazardous as they contain lead and has relatively low energy density. Whereas li-ion based battery, although currently the popular choice for modern technology, will suffer from degradation from constant charging and

discharging. Furthermore, lithium itself is a finite resource on earth. This provides motivation for exploring alternative power source and storage element, such as the hydrogen gas.

Hydrogen, although abundant, cannot be found naturally and often exists as part of the other compound. The main method to produce hydrogen involves steam reforming fossil fuels, which would in turn requires high capital. The by-product of carbon dioxide would also be an environmental issue.

As such, the electrolysis process carried by an electrolyzer unit to extract hydrogen gas from water [1][2] is more practical for small scale [3] and relatively clean. The gas is then consumed as fuel by the PEM fuel cell to generate electricity with only water and a small amount of heat as the by-product [4][5]. Moreover, the stored hydrogen gas can be used as a clean source of combustible fuel for household cooking. The PEM fuel cell is also well-developed compared to other fuel cell technology, has a quick start-up of less than 15 seconds and a long operating life cycle. This sums up the incentive of using hydrogen gas and the technology that comes with it as a source of clean power.

The research carried out and presented in this write up showcases the specification and performance in implementing the electrolyzer unit coupled with the PEM fuel cell into a typical solar energy harvesting system. Table 1 shows several projects related to energy production using the combination of solar panel, electrolyzer and PEM fuel cell.

The effect of temperature on the electrolyzer unit was investigated in [6] and [7] whereas the effect of pressure on the PEM fuel cell stacks was carried in [7]. However, both of these research work was limited to simulations. The works of [8] and [9] were targeted for small-scale usage and can still be considered as proof-of-concept designs. Moreover, the effect of catalyst and hydrogen gas flow was not investigated in any of the works in [6] - [9] which actually would greatly impact the efficiency of the system.

2. METHODOLOGY AND IMPLEMENTATION

Figure 1 shows the overall design and operational flow diagram of the proposed system. For the purpose of performance validation, during the daytime, the system is used to concurrently generate hydrogen gas and charge up the lead-acid battery, with priority given to gas generation. By design, the solar panel would have excess energy during the day. This excess energy is used to charge up the battery as well. A single axis solar tracker was also installed to increase the efficiency of solar energy harvested.

If the load is required for operation during the daytime, it will be powered by the PEM fuel cell which in turn is powered by the solar panel. In case the PEM fuel cell ran out of hydrogen gas or insufficient sunlight is available, then the system will automatically switch to the battery to ensure uninterrupted power supply. All of these features were implemented in the power management unit which also includes over- and under-voltage protection circuitry. The prototype of the system is shown in Figure 2.

Table 1: Recent works in Solar Powered-based Electrolyzer and PEM Fuel Cell

Related Works	Features	Limitation(s)
Ates, Shekardasht and Canli [6]	Presented simulations on a practical implementation of solar panel, electrolyzer unit and PEM fuel cells into a working system for up to 1000 W. Investigated the effect of temperature and pressure on electrolyzer. Also investigated the hydrogen flow rate to PEM fuel cell.	<ul style="list-style-type: none"> • Purely simulation-based using Matlab-Simulink. • The effect of catalyst for electrolysis and PEM fuel cell was not investigated.
Khater, Abdelraouf and Beshr [7]	Optimised the operating conditions for the electrolyzer (temperature and pressure) and PEM fuel cell (pressure) to ensure economical usage for the standalone residential solar-powered system.	<ul style="list-style-type: none"> • Simulation-based using Matlab. • Does not simulate the effect of hydrogen flow.
Mojica, Chuang and Ruiz [8]	Developed gravity-assisted gas storage for hydrogen and oxygen. The PEM fuel cell generates a maximum of 0.6 W power produced from 400 mL of hydrogen per hour.	<ul style="list-style-type: none"> • More of a proof of concept instead of a complete standalone solution. • No protection mechanism implemented.
Wilson, Srinivasan, Moore, Henderson, III and Sharma [9]	The hydrogen gas was generated using solar-powered electrolyzer and stored in a metal hydride canister. The gas is then used to power a remote car (6 V, 2 A).	<ul style="list-style-type: none"> • The intermittent output of power due to the non-constant flow of hydrogen from the canister. This is caused by the cooling down of the hydrogen gas, interrupting its flow.

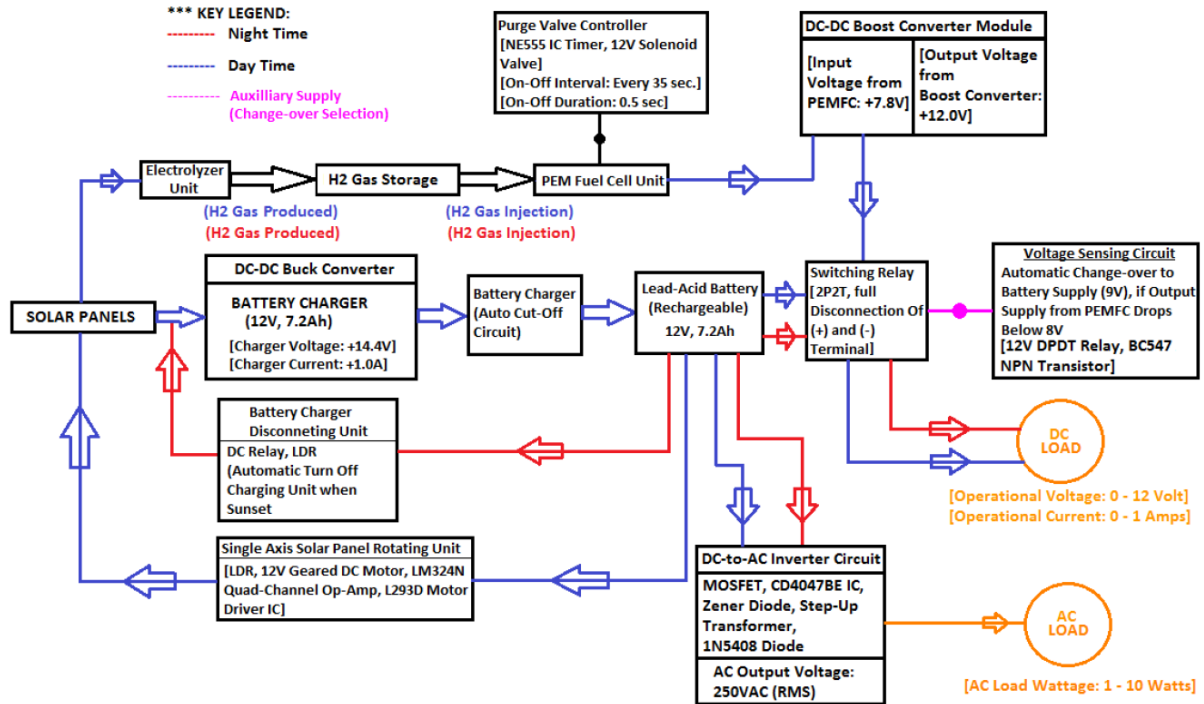

Figure 1: The proposed system which primarily consists of the solar panel, power management unit, lead-acid battery, single axis solar tracker, electrolyzer unit and PEM fuel cell.

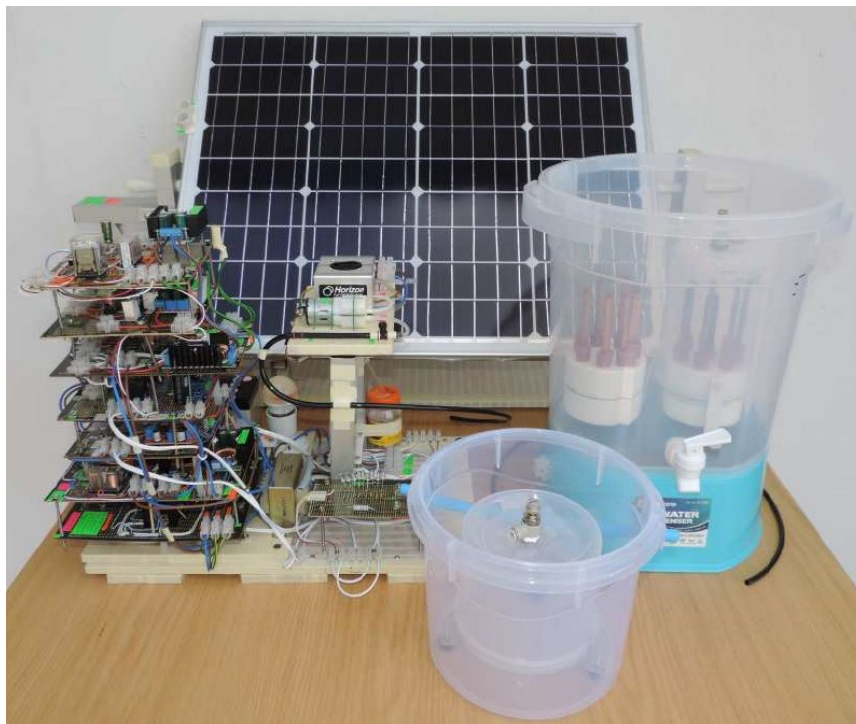

Figure 2: The prototype of the proposed system

The electrolyzer unit uses distilled water as its solvent with the addition of the Potassium Hydroxide (KOH) powder flakes as its solute. KOH is added to facilitate the current flow through the electrolyte solution for the process of electrolysis (Figure 3). 10% of KOH

electrolyte solution is used to provide a balance between the ionic conductivity of the electrolyte and also corrosion resistance on the electrode. The total amount of electrolyte solution used after adding with the KOH flakes is 9 L.

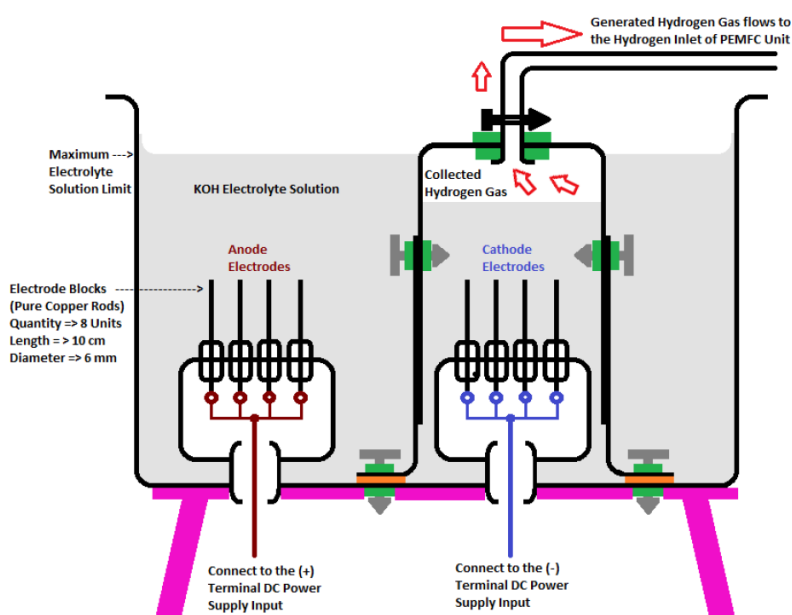

Figure 3: Arrangement of the the electrolyzer unit for electrolysis process, which produces hydrogen for fuelling the PEM fuel cell (PEMFC)

Pure copper rods are used as the electrode in the electrolyzer unit for the discharge of the hydrogen gas (cathode) and oxygen gas (anode). Pure copper rods are selected as it has low bubbles overpotential value. A high overpotential value indicates a more difficult gas production due to the reduction in the effective surface area for the current density on the surface of the electrodes. In other words, when the bubbles overpotential increases, a higher amount of electric current is required to liberate the gas from the electrode surface.

Polypropylene (PP) container are used for the electrolysis and hydrogen gas storage as it is safe to be in contact with the alkaline substance and having a high melting point (130°C to 171°C.) This setup is suited for the study conducted, although in a larger scale, the proper container should be used, such as those made out of metal hydride [10] and sorbent.

To ensure a stable flow of hydrogen gas into the PEM fuel cell, a small air pump is installed at the outlet port of the hydrogen gas tank to increase the PEM fuel cell inlet pressure, on top of the atmospheric pressure. At least 50 kPa to a maximum of 115 kPa of inlet pressure is applied for proper fuel cell stack function. This is to avoid intermittent power due to unreliable hydrogen gas supply into the PEM fuel cell.

3. RESULTS AND DISCUSSION

Table 2 verifies the reduction of internal resistance to facilitate the electrolysis process through the addition of KOH (10%). In essence, if the internal resistance of the distilled water is too high, then the electrolysis process could not be triggered or carried out efficiently. For a 24-hour of continuous operation, 500 mL of electrolyte solution is consumed by the electrolysis process and due to evaporation.

The correlation between output voltage from the PEM fuel cell with the hydrogen gas flow is shown in Table 3. From tests performed, about 400 mL of hydrogen gas is generated from the electrolyzer every 17 minutes. The boost converter is also installed to stabilize the output voltage from the PEM fuel cell and to bring the voltage up to 12 V, if required.

Table 2: The amount of KOH (potassium hydroxide) powder flakes added to the 9000 mL of distilled water inside the electrolyzer unit tank, with respect to the changes in the internal resistance of the distilled water

Amount of Potassium Hydroxide Powder Flakes added (Grams)	Cumulative amount of Potassium Hydroxide Powder Flakes added (Grams)	Distilled Water's Internal Resistance (Ohms) (Ω)	Total Amount of Distilled Water inside the Electrolyzer Unit Water Tanks (mL)	Does Saturation of Potassium Hydroxide solution takes place? (Yes/No)
-	-	8600	-	-
100	100	2100	9000	No
200	300	800	9000	No
150	450	360	9000	No
150	600	210	9000	Close to Saturation
100	700	145	9000	Yes
100	800	130	9000	Yes
100	900	120	9000	Yes

Table 3: Uncompressed hydrogen gas flow versus output voltage at the PEM fuel cell with no load connected

Hydrogen Gas Flow per minute (mL/min)	Generated Output Voltage from PEMFC Stacks (V)
439	9.5
420	9.2
383	8.8
351	8.2
337	7.3
298	5.5
41	0.15

With the sun tracker operational, optimal sunlight can be obtained for 5 hours, starting from 11 am to 4 pm. With 5 hours of sunlight, the hydrogen gas production would total up to 7059 mL, which can sustain the 500 mA DC load for nearly 28 minutes. Assuming a low power load of only 50 mA, it can then be powered up continuously for 4.7 hours. The optimal specification and performance of the proposed system are tabulated in Table 4.

When the electrolyzer unit is connected to the solar panel, the open-circuit voltage is reduced to around 71%. At the same time, the hydrogen gas is being produced at the electrolyzer, around 540 mA of current is supplied to the lead-acid battery. At this nominal rate, the lead-acid could be fully charged within 17 hours, which means 3 days of full daytime charging is required. Practically, the current supplied to the battery would fluctuate depending on the sunlight

intensity and the level of voltage at the battery; the higher the voltage, the lower the current supplied as the battery slowly reaches its saturation point.

Table 4: Optimal performance of the proposed system

Element	Associated values
Solar panel output	50 W rating @ 6.2 V, 3 A
Krypton Lamp (DC load)	5 V, 500 mA
Acid lead battery (12 V, 7.2 Ah)	17 hours to reach full charge from the depleted state with an average of 540 mA supplied
Electrolyzer Unit (output)	5 V, 1.8 A
Hydrogen gas production	0.39 mL every second or 400 mL every 17 minutes
Hydrogen gas consumption rate by DC load	400 mL sustains load for 1 minute 35 seconds

4. CONCLUSION

The proposed solar-powered electrolyzer and hydrogen fuel cell prototype explores the option of using hydrogen gas as the energy source and storage medium which complements with the traditional off-grid solar energy harvesting system. The hydrogen gas is produced by the electrolyzer unit through the electrolysis process which may be stored or in turn used by the PEM fuel cell to power up the load. The implementation of the electrolyzer unit and PEM fuel cell addresses the objectives of integrating both as a practical design to consolidate the solar energy-based system.

Experimental results showed that the design is feasible in small-scale; where during daytime the hydrogen gas could be nominally accumulated at a rate of 400 mL every 17 minutes and then stored in the polypropylene container as much as 7059 mL per day. The system then supplies DC power for powering up preferably very light load (5V, 50 mA) continuously for 4.7 hours in night mode. Alternatively, if the hydrogen gas is depleted, the system would automatically switch to lead-acid battery to continue the load operation.

REFERENCES

- [1] I. S. Ganeshan, V. V. S. Manikandan, V. R. Sundhar, R. Sajiv, C. Shanthi, S. K. Kottayil and T. Ramachandran, "Regulated Hydrogen Production using Solar Powered Electrolyser," *International Journal of Hydrogen Energy*, vol 41, issue 24, pp. 10322-10326, 2016.
- [2] J. Chi and H. Yu, "Water Electrolysis Based on Renewable Energy for Hydrogen Production," *Chinese Journal of Catalysis*, vol. 39, issue 3, pp. 390-394, 2018.
- [3] I. Staffell, D. Scamman, A. V. Abad, P. Balcombe, P. E. Dodds, P. Ekins, N. Shah and K. R. Warda, "The Role of Hydrogen and Fuel Cells in the Global Energy System," *Energy & Environmental Science*, issue 2, pp. 463-491, 2019.
- [4] O. F. Selamat, F. Becerikli, M. D. Mat and Y. Kaplan, "Development and Testing of a Highly Efficient Proton Exchange Membrane (PEM) Electrolyzer Stack," *International Journal of Hydrogen Energy*, vol. 36, issue 17, pp. 11480-11487, 2011.

- [5] T. Abbasi and S. A. Abbasi, “‘Renewable’ Hydrogen: Prospects and Challenges,” *Renewable and Sustainable Energy Reviews*, vol. 15, issue 6, pp. 3034-3040, 2011.
- [6] A. Ateş, S. Z. Shekardasht and E. Canli, "Solar Energy Supported Hydrogen Production: A Theoretical Case Study," *Selcuk University Journal of Science, Engineering and Technology*, vol. 5, issue 4, pp. 536 - 554, 2017.
- [7] H. A. Khater, A. A. Abdelraouf and M. H. Beshr, “Optimum Alkaline Electrolyzer-Proton Exchange Membrane Fuel Cell Coupling in a Residential Solar Stand-Alone Power System,” *International Scholarly Research Notices (Renewable Energy)*, vol. 2011, 2011.
- [8] F. E. Mojica, P-Y. A. Chuang and U. Ruiz "Solar Regenerative Hydrogen Fuel Cell Charging System," 2017 ASEE Annual Conference & Exposition, 2017.
- [9] J. F. Wilson, S. S. Srinivasan, B. M. Moore, L. Henderson, S. E. III and P. C. Sharma, “Hydrogen Production Using Solar Energy,” *Journal of Undergraduate Research in Physics*, 2013.
- [10] C. Spiegel. Hydrogen Storage. [Online]. Available at <https://www.fuelcellstore.com/hydrogen-equipment/hydrogen-storage>