

# Machine Learning–Based Fault Detection for Condition Monitoring of a Three-Phase Induction Motor Using Current Signature

Hussain Mehboob\*, Asim Hussain, Muhammad Abdullah Chohan, Dr. Mansoor Asif, Dr. Abbas Uğurenver

**Abstract**— In developed nations, motors use between 40 and 50 percent of the total capacity produced. Induction motors need special care since they are prone to errors. There are a few systems that can identify motor defects using heat, current, and vibration analysis, but they are costly, invasive, and not appropriate for small businesses. Current Signature Analysis can be used to identify most motor defects. In this study, broken bar faults in induction motors (IMs) are analyzed using stator current and voltages to assess machine learning-based methodologies. For both healthy and faulty motors, the discrete wavelet transform (DWT) is used to retrieve the features. The experimental setup used LVDAC systems to extract stator current and voltage signals from the motor through EMS Software. Discrete Wavelet Transforms (DWT) have been applied to these signals to extract the required frequency components of those signals through MATLAB. Different machine learning models are trained to evaluate the performance for broken rotor bar defect diagnosis. Different classification techniques such as Support Vector Machines-SVM, k- nearest Neighbor-KNN, Ensemble, Decision Tree, Linear discriminant, and Nave Bayes are applied on data of stator current to find which algorithm is giving the highest percentage of efficiency. KNN classification model was providing the highest efficiency. The proposed model can detect whether the motor is healthy or if some percentage of fault has occurred in it so as to plan maintenance in the near future depending upon the percentage of fault.

**Index Terms**— Current Signature Analysis, Discrete Wavelet Transform, Induction Motor, Machine Learning, Condition Monitoring.

## I. INTRODUCTION

Due to their dependability, tough design, and low maintenance requirements, induction motors are widely utilized in both industrial and home settings [1]. However, to maintain

continuous operations in industrial processes, defect detection and condition monitoring are crucial.

Emerging flaws can cause financial losses, downtime, and maintenance hiccups [2]. A broken rotor bar is a typical electrical defect that industrial motors encounter; it causes more than 10% of all motor failures [3]. This kind of failure can lead to serious difficulties like variable speed and torque, poor stator winding insulation, temperature increases, and decreased efficiency. To reduce safety issues and operating losses, rigorous condition monitoring is therefore required [4]. Induction motors can suffer from a variety of faults, both electrical and mechanical, which can significantly impact their performance. Electrical faults include broken rotor bars, eccentricity faults, and stator winding defects, while mechanical faults often involve bearing wear and misalignments. These faults can manifest as abnormal frequencies in current or vibration signatures and require precise diagnostic methods to identify and mitigate [5-8].

The sidebands of the fundamental frequency at  $(1 \pm 2s)$  fs in the stator current spectrum, where fs is the fundamental frequency and s is the slip of the motor, are increased by magnetic asymmetry brought on by a broken bar fault [9]. This method must be improved, though, as it is prone to false detection [10]. Bearing faults, for instance, occur due to the wear and tear of bearing balls, leading to added frequency components at specific locations based on the supply frequency and rotor speed. Similarly, eccentricity faults arise from unequal air gaps between the stator and rotor, categorized into static and dynamic types, each affecting motor performance differently. Stator faults, including coil-to-coil or phase-to-phase failures, are particularly destructive and may result in motor breakdowns if undetected. Finally, rotor faults, such as bar breakages, are often caused by thermal stress, fatigue, or load imbalances, introducing additional harmonics into the motor's operational spectrum.

Impending defects can now be identified by stray flux, vibration, temperature, and acoustic noise signature extraction analyses in both time and frequency domains [11]. For both offline and online applications, knowledge-based algorithms can offer fault detection and categorization. Machine learning algorithms have great potential in detecting faults in induction machines, especially in industrial applications [12]. The objective of this research is to develop a condition monitoring and maintenance decision support algorithm that will help in protecting from sudden shut down of the work in the industry to minimize financial losses.

This manuscript is submitted on November 12, 2025, revised on January 23, 2026, accepted on February 20, 2026 and published on April 30, 2026.

Hussain Mehboob (email: [hussainmehboob@stu.aydin.edu.tr](mailto:hussainmehboob@stu.aydin.edu.tr)) and Dr. Abbas Uğurenver (email: [abbasugurenver@aydin.edu.tr](mailto:abbasugurenver@aydin.edu.tr)) are with Department of Electrical and Electronics Engineering, Istanbul Aydin University, Istanbul, Türkiye.

Asim Hussain (email: [ahussain.bee19seecs@seecs.edu.pk](mailto:ahussain.bee19seecs@seecs.edu.pk)), Muhammad Abdullah Chohan (email: [mchohan.bee19seecs@seecs.edu.pk](mailto:mchohan.bee19seecs@seecs.edu.pk)), and Dr. Mansoor Asif (email: [mansoor.asif@seecs.edu.pk](mailto:mansoor.asif@seecs.edu.pk)) are with National University of Sciences and Technology, Islamabad, Pakistan.

\*Corresponding author  
Email [hussainmehboob@stu.aydin.edu.tr](mailto:hussainmehboob@stu.aydin.edu.tr)

1985-5389/© 2026 The Authors. Published by UiTM Press. This is an open access article under the CC BY-NC-ND license (<http://creativecommons.org/licenses/by-nc-nd/4.0/>).

## II. LITERATURE REVIEW

### A. Condition Monitoring of Electrical Machine

Condition monitoring is a process in which continuously or after some time the health of any electrical machine is monitored. This process involves analyzing whether there is any change in the pattern of current and voltage due to temperature, wear and tear, vibrations, etc. It is the foremost part of the predictive maintenance of any electrical machine for the planned and preventive shutdown of the operation in any industry or place where any electrical machines are placed [13, 14]. There are some traditional techniques for condition monitoring discussed below.

### B. Vibrational Analysis

This technique analyzes motor vibration signals to identify potential abnormalities in the motor. These vibrational signals carry information in their signature regarding the exciting forces and path through which the signal can propagate toward transducers. Various signal processing techniques, including FFT, machine learning, neural networks, and wavelet analysis, are employed to analyze and monitor the vibrational signature of the signal further [15]. By analyzing the time domain and frequency domain spectrum through different signal processing techniques both faults and the nature of the frequencies can be identified [16, 17].

### C. Current Analysis

In this technique, the current of the motor is used to analyze the condition of the motor to facilitate early detection of potential abnormalities present in the motor. Different sensors such as current sensors, current transformers, and hall effect sensors are commonly used for this technique [18, 19]. The major advantage of this technique is that it is non-invasive and can be implemented in situation or during normal operation without affecting the operation of the motor.

### D. Thermal and Acoustic Analysis

Thermal analysis involves evaluating motor temperature signals to detect abnormalities. A temperature sensor such as a thermocouple and resistance temperature detector are used for this technique [20,21].

Acoustic Analysis technique uses the acoustic emissions of the motor to detect or predict any abnormality present in the motor. Microphones and acoustic transducers are used in this technique. Additional signal processing techniques are applied to the acoustic signal for further analysis of the signal. Acoustic analysis evaluates the spectral patterns of motor emissions, from which features are extracted for classification using modern machine learning algorithms for the prediction of the fault [22].

### E. Motor Current Signature Analysis

Motor current signature analysis utilizes the current waveform of the motor for predicting the abnormality in the motor. The stator current of the motor is required in the case of the induction motor for fault detection. In the case of the healthy motor, there will be a sharp frequency spectrum at 50 Hz and there will be no extra harmonics present in the motor current. This spectrum can be analyzed using techniques of signal processing such as fast Fourier transform (FFT).

However, when a fault occurs in the motor then the signature of the current holds the extra frequency components in the signal. In the time domain, these components are often difficult to observe unless the fault is severe and the motor is about to break. But those components can be analyzed and detected when we apply signal processing techniques to the current signal. Additional spectral components beyond 50 Hz indicate possible faults, whose severity correlates with the magnitude of the sidebands. Fig. 1 displays the frequency spectrum of the current and flux signals at full load for the tested healthy motor [23].

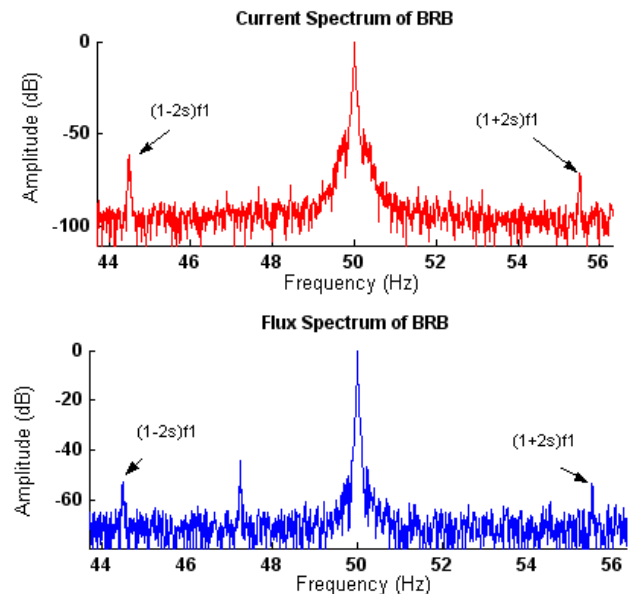

Fig. 1. Frequency spectrum of the current and flux signals of healthy motor [23]

The sidebands surrounding the supply frequency, calculated as  $(1 \pm 2s)f_1$ , are fundamental in the identification of Broken Rotor Bar (BRB) faults. The amplitudes of these sidebands are used to assess the severity of the BRB fault. In the current spectrum the sidebands are found at 44.20 Hz (61.70 dB) and at a frequency of 55.51 Hz (-70.93 dB) while for the flux spectrum, these frequencies are 44.20 Hz (-52.56 dB) and 55.51 Hz (53.01 dB) respectively. It can be concluded therefore that with the aid of the current spectrum, BRB faults are easier to locate than with the use of the flux spectrum [23]. A simplified schematic of the setup is shown in Fig. 2.

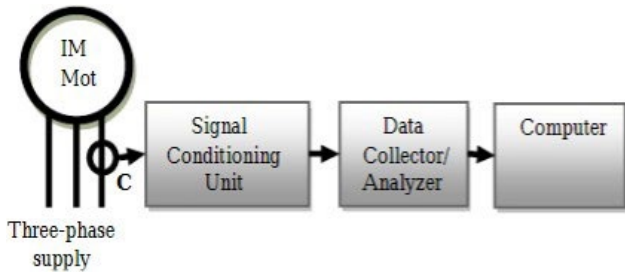

Fig. 2. Block diagram for Motor Current Analysis

### III. METHODOLOGY

This study involved modeling an induction motor, introducing rotor faults, data acquisition of stator current, application of the Discrete Wavelet Transform, feature selection of the current signal, and applying machine learning algorithms for classification of healthy and faulty motor conditions.

#### A. Modeling of induction motor

To obtain simulation data, an induction motor was designed using Ansys Maxwell software providing a variety of output metrics such as current, speed, torque, and magnetic field dispersion. Fig. 3(a) and 3(b) depict a 2D cross-section view of an induction motor model. The tested motor model has a rated power of 0.37 kW with 26 slots in the rotor and 36 slots in the stator and operates at 50Hz supply frequency. Table 1 and Table 2 give the properties of the rotor and stator respectively designed using Ansys Maxwell.

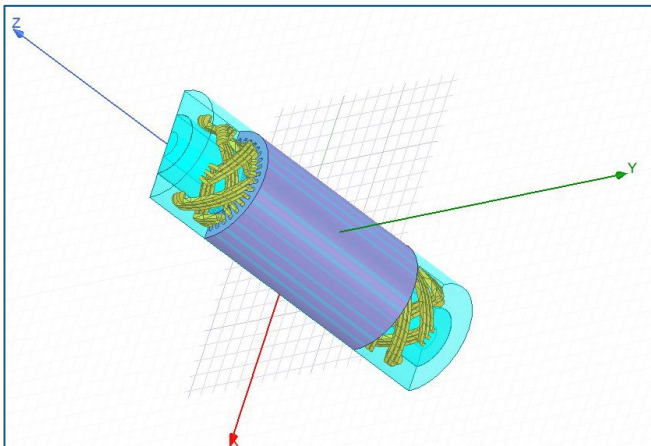

Fig. 3a. Induction Motor Model in Ansys Maxwell

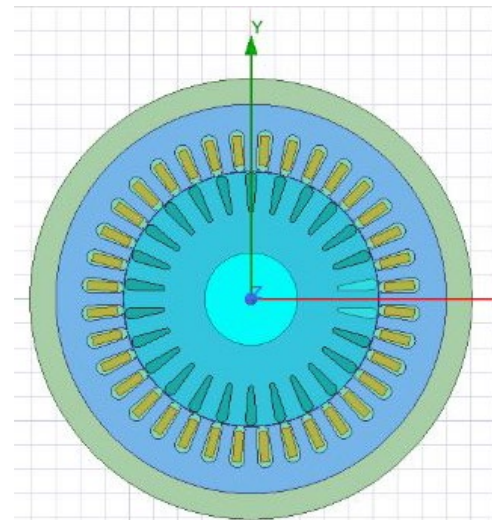

Fig. 3b. Induction Motor Model in Ansys Maxwell

TABLE 1: PROPERTIES OF ROTOR

Name	Value	Unit
Stacking Factor	0.95	-
Number of slots	26	-
Slot Type	1	-
Outer Diameter	104.5	mm
Inner Diameter	38	mm
Length	120	mm
Steel Type	Steel_1008	-
Skew Width	1	-
Cast Rotor	-	-
Half Slot	-	-
Double Cage	-	-

TABLE 2: PROPERTIES OF STATOR

Name	Value	Unit
Outer Diameter	160	mm
Inner Diameter	105	mm
Length	120	mm
Stacking Factor	0.95	-
Steel Type	Steel_1008	-
Number of slots	36	-
Slot Type	2	-
Lamination Sectors	162	-
Press Board Thickness	0.68	mm
Skrew Width	0	-

Fig. 4(a) and 4(b) display the voltage and flux waveform of the induction motor model designed in the Ansys Maxwell for this study respectively.

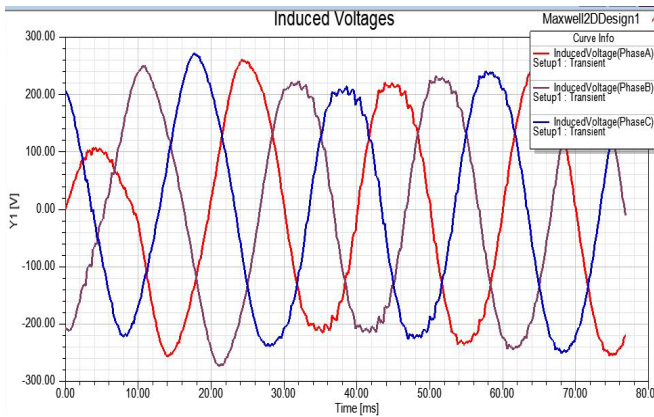

Fig. 4a. Voltage waveform

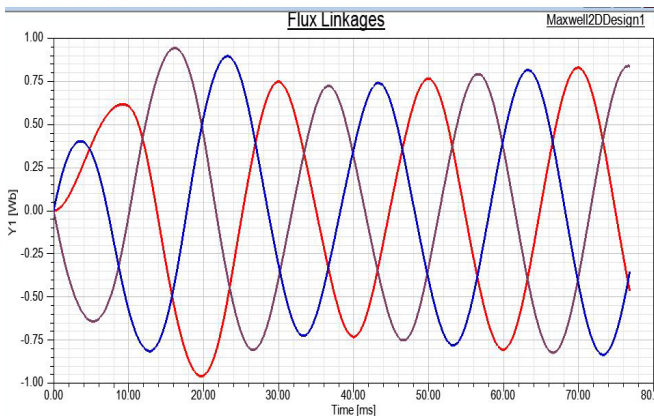

Fig. 4b. Flux waveform

*B. Introducing fault in the rotor and Data Acquisition*

A fault was generated in the model by lowering the conductivity of the rotor bar material by two orders of magnitude. The broken bar fault disrupts the magnetic symmetry of the air gap flux, which is mirrored in the stray magnetic flux around the motor. This results in a change in stator current. The stator current decreased as the fault was introduced in the rotor bar due to the weakening of magnetic flux. A three-phase induction motor was used to test all the observations from the simulated model. Data Acquisition was performed on stator current for both healthy and damaged bar examples to validate the diagnostic capabilities of various machine learning algorithms. Both simulated and experimental datasets were utilized for this research. Simulated data was generated using the induction motor model in Ansys Maxwell while real data was generated using Lab-Volt Data Acquisition and Control (LVDAC)-EMS systems of the lab.

*C. Hardware Implementation*

A three-phase induction motor of 1360 RPM and 0.37 KW power with rated current of 1.09 A for 50Hz and 1.90 A for 60Hz was used for real data. The three-phase induction motor was operated using the LVDAC-EMS system under no-load and 30% load conditions to capture current and voltage waveforms. The acquired signals were subsequently processed using the Discrete Wavelet Transform (DWT) to extract relevant frequency components for model training. Fig. 5(a),

5(b), and 5(c) display the name plate, rotor, and stator of the motor.



Fig. 5a. Name plate of motor



Fig. 5b. Rotor of motor



Fig. 5c. Stator of motor

*1) Introducing faults in motor*

A single-bar defect was introduced by drilling a hole into one of the rotor bars to simulate a broken rotor bar fault. Current and voltage waveforms from that faulty motor were again extracted with a 2.2% fault in it since only 1 bar out of 26 bars was drilled of the motor. Subsequently, an additional hole was drilled in the rotor to introduce more than 2.2% fault in the motor. It was observed that the amount of current that the induction motor was consuming when it was healthy had decreased as electric fault was introduced in motor. The reason for this is that when rotor is affected by fault the magnetic field produced is weaker as compared to healthy one and this weak

magnetic field leads to the decrease in current. Fig. 6 displays the faulty rotor which was used for data extraction for this study.



Fig. 6. Faulty rotor

D. Feature Extraction using Discrete Wavelet Transform

In this study, the Discrete Wavelet Transform (DWT) was employed to identify anomalies in current signals associated with broken-bar faults. The anomaly in the signals can be detected using Discrete Wavelet Transform (DWT) to detect the broken bar failure. The wavelet transform specifies a signal that is decomposed into wavelets and then limited by frequency and time [24]. The Daubechies family of wavelets was utilized due to its proven efficiency in representing non-stationary signals. The **db4** family with **six-level** decomposition was chosen for current decompositions, as shown in Fig. 7.

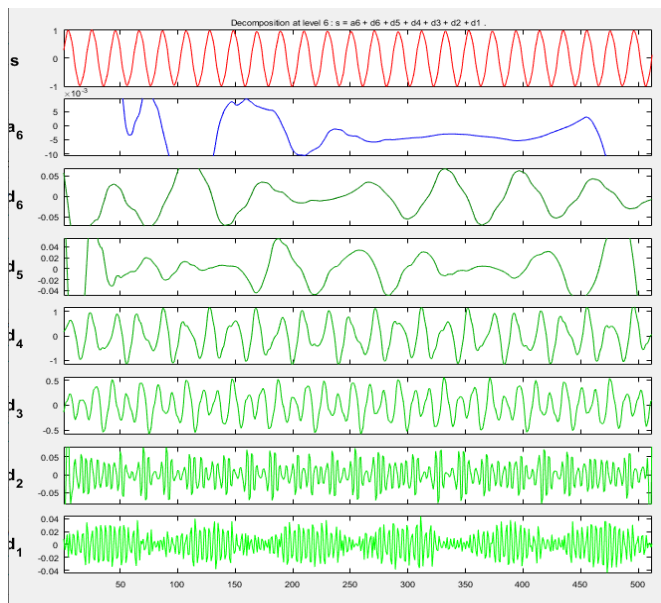

Fig. 7. Discrete Wavelet Transform on the current signal

The Daubechies-4 (db4) wavelet was selected due to its ability to effectively represent non-stationary stator current signals with sharp transient characteristics. Compared to

higher-order Daubechies wavelets (e.g., db6), symlets, and coiflets, db4 offers better time localization while maintaining sufficient frequency resolution, which is critical for identifying broken rotor bar–related disturbances. Preliminary comparative evaluations showed that db4 produced more consistent statistical features and higher classification accuracy. A six-level decomposition was adopted to ensure adequate coverage of fault-related frequency bands without introducing redundant information.

Ten statistical characteristics were selected from among all other Daubechies to analyze stator current signals for the feature extraction process. The generated statistical features acquired after DWT processing the data are mean, median, maximum, and minimum, standard deviation, median and mean absolute deviations, L1 Norm, L2 Norm, and Maximum Norms. L1 and L2 norms are the sum of absolute values of its components and the square root of the sum of absolute values of its components, respectively. Table 3 and Table 4 show the sample extracted features of healthy current signal and faulty current signal respectively.

The dataset consisted of stator current signals collected from healthy and faulty motor conditions under no-load and 30% load operation. After DWT-based feature extraction, the dataset was divided into training and testing subsets using the internal validation mechanism of the MATLAB/Simulink Classification Learner. Multiple classifiers were trained under identical conditions to ensure consistency and reproducibility.

TABLE 3: SAMPLE FEATURE OF HEALTHY CURRENT SIGNAL

Sample	Mean	Median	Max	Min	SD	Med Abs Dev	Mean Abs Dev	L1 Norm	L2 Norm	Max Norm	Status
s1	-0.00271	0.007	1.061	-1.083	0.7209	0.6875	0.6507	333.1	16.3	1.083	Healthy
s2	-0.00737	-0.0085	1.061	-1.083	0.719	0.6815	0.649	332.3	16.25	1.083	Healthy
s3	-0.00223	0.002	1.061	-1.076	0.7203	0.682	0.6503	333	16.28	1.076	Healthy
s4	-0.00232	-0.012	1.083	-1.1	0.7195	0.678	0.649	332.3	16.27	1.1	Healthy
s5	-0.00936	-0.004	1.064	-1.066	0.721	0.68	0.6505	333	16.3	1.066	Healthy
s6	-0.00708	-0.016	1.085	-1.076	0.7195	0.681	0.649	332.3	16.27	1.085	Healthy
s7	-0.0098	-0.004	1.051	-1.078	0.7195	0.6755	0.6492	332.4	16.27	1.078	Healthy
s8	-0.0091	0.003	1.076	-1.078	0.7194	0.684	0.6493	332.4	16.26	1.078	Healthy
s9	0.0016	0.015	1.064	-1.068	0.7192	0.6755	0.6491	332.6	16.26	1.068	Healthy
s10	0.00342	-0.012	1.085	-1.1	0.7197	0.68	0.6496	332.6	16.27	1.1	Healthy

TABLE 4: SAMPLE FEATURE OF FAULTY CURRENT SIGNAL

Sample	Mean	Median	Max	Min	SD	Med Abs Dev	Mean Abs Dev	L1 Norm	L2 Norm	Max Norm	Status
fn1	0.1032	0.1936	0.894	-0.883	0.6004	0.541	0.5516	279.2	13.77	0.894	Faulty
fn2	0.1039	0.2045	0.873	-0.905	0.5998	0.5225	0.5298	279.3	13.76	0.905	Faulty
fn3	0.1014	0.1865	0.883	-0.879	0.5971	0.5405	0.5293	277.7	13.69	0.883	Faulty
fn4	0.1007	0.192	0.886	-0.886	0.6019	0.542	0.5328	280	13.8	0.886	Faulty
fn5	0.1043	0.21	0.883	-0.896	0.5996	0.521	0.5297	279	13.76	0.896	Faulty

Sample	Mean	Median	Max	Min	SD	Med Abs Dev	Mean Abs Dev	L1 Norm	L2 Norm	Max Norm	Status
fn6	0.104	0.211	0.869	-0.894	0.5999	0.522	0.5308	279.9	13.76	0.894	Faulty
fn7	-0.00392	-0.0065	0.886	-0.896	0.6082	0.6135	0.5449	279	13.75	0.896	Faulty
fn8	-0.0043	-0.004	0.892	-0.886	0.6107	0.621	0.5481	280.7	13.8	0.892	Faulty
fn9	-0.00426	-0.019	0.888	-0.879	0.6088	0.616	0.5456	279.9	13.76	0.888	Faulty
fn10	-0.00675	-0.013	0.877	-0.879	0.6092	0.613	0.5466	279.9	13.77	0.879	Faulty

IV. RESULTS AND DISCUSSION

A. Visual Difference in Healthy and Faulty Motor Spectra

The amplitude spectrum represents the frequency components of a signal and their corresponding amplitudes. In the case of induction motors, the amplitude spectrum is used to analyze the frequency content of the stator current signal. By comparing the amplitude spectrum of a healthy motor to that of a faulty motor, abnormalities can be detected and analyzed.

In this case, the amplitude spectrum of the faulty motor exhibits two abnormal peaks. These peaks may indicate the presence of specific frequencies that are not present in a healthy motor or are present at much lower amplitudes. These abnormal frequencies confirm the presence of a rotor fault intentionally introduced by drilling a hole in one of the rotor bars. Figs 8(a) and 8(b) illustrate the current spectra of the healthy and faulty motors, respectively.

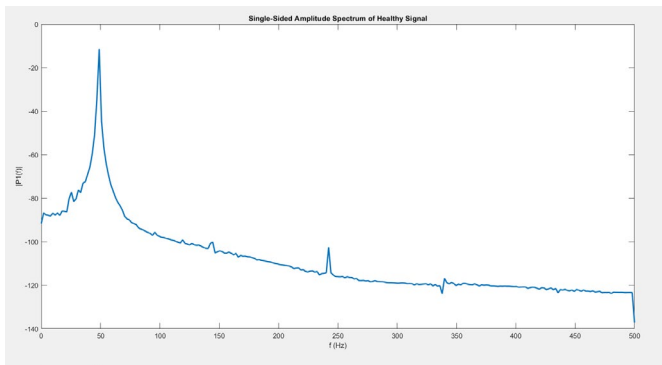

Fig. 8a. Current spectrum of healthy motor

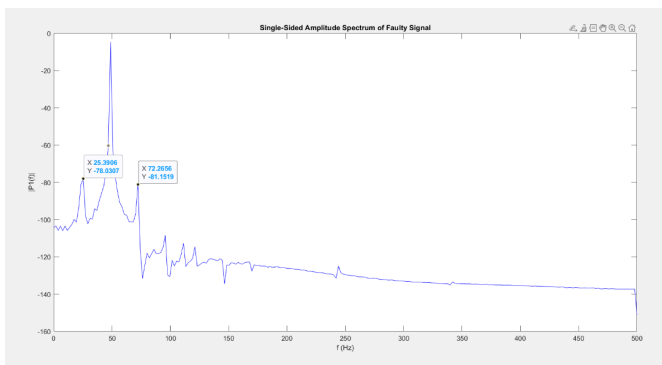

Fig. 8b. Current spectrum of faulty motor

B. Classification Performance

To evaluate the performance of broken rotor bar fault diagnosis, classification techniques including Support Vector Machine (SVM) [25], k-Nearest Neighbors (KNN) [26],

Ensemble Learning [27], Decision Tree [28], Linear Discriminant Analysis (LDA), and Naïve Bayes [29] were employed. SVM employs statistical learning for classification and regression, whereas k-NN uses effective distance to classify an unknown by comparing it to a known case.

Machine learning models were implemented using the MATLAB/Simulink Classification Learner environment, which provides a unified framework for training and validating multiple classifiers. The extracted feature dataset was used to train various models under default hyperparameter configurations and internal validation schemes, ensuring a fair comparison. Table 5 gives the classification efficiencies of the models for the data collected for this study.

TABLE 5: CLASSIFICATION EFFICIENCIES OF THE ML MODELS

Classification Model	Accuracy (Validation)
Support Vector Machine (SVM)	96.2%
k-Nearest Neighbors (KNN)	100%
Ensemble Learning	61.3%
Decision Tree	97.6%
Linear Discriminant Analysis (LDA)	98.2
Naïve Bayes	98.2%

Among the evaluated classifiers, the K-Nearest Neighbors (KNN) algorithm consistently achieved the highest classification accuracy, while other models exhibited comparatively lower performance. Therefore, KNN was selected for detailed analysis and presentation. Fig. 9 displays the confusion matrix of the selected KNN classification model.



Fig. 9. Confusion matrix of the ML classification model

V. LIMITATION

It should be noted that the experimental validation was performed under no-load and 30% load conditions. Although these conditions demonstrate the effectiveness of the proposed approach, variations in load can influence stator current signatures and classification accuracy. In practical industrial environments, higher loads may enhance fault-related spectral components, while fluctuating loads may introduce additional noise. Future work will extend the analysis to broader load

variations and incorporate explicit hyperparameter optimization to enhance robustness.

## VI. CONCLUSION

This study demonstrates the effectiveness of the proposed methodology for detecting faults in induction motors. The use of the Discrete Wavelet Transform (DWT) for feature extraction was beneficial because of the method's excellent time-frequency resolution, which is critical to diagnosing faults precisely and reliably. Unlike the Fourier Transform, the DWT offers time-frequency localization, multi-resolution analysis, and data noise suppression while extracting features sensitive to faults from stator current signals. The combination of machine learning and DWT-based feature extraction improves the diagnostics and defect detection necessary for condition monitoring and maintenance decision support in the target industries. Analysis of stator currents, DWT, and machine learning facilitates the efficient and dependable approach for broken rotor bar fault detection and condition monitoring and maintenance decision support of induction motors, as the results indicate.

## VII. ACKNOWLEDGMENT

Authors would like to express their sincere gratitude to the administration of National University of Sciences and Technology (NUST) Islamabad, Pakistan and Istanbul Aydin University for their financial support and facilities provided for this research.

## REFERENCES

- [1] Hubert, C. I. (2002). *Electric machines: Theory, operation, applications, adjustment, and control* (2nd ed.). Prentice Hall.
- [2] Heng, A., Zhang, S., Tan, A. C., & Mathew, J. (2009). Rotating machinery prognostics: State of the art, challenges, and opportunities. *Mechanical Systems and Signal Processing*, 23(3), 724-739.
- [3] Bellini, A., Filippetti, F., Tassoni, C., & Capolino, G. A. (2008). Advances in diagnostic techniques for induction machines. *IEEE Transactions on Industrial Electronics*, 55(12), 4109-4126.
- [4] Benbouzid, M. E. H. (2000). A review of induction motors signature analysis as a medium for fault detection. *IEEE Transactions on Industrial Electronics*, 47(5), 984-993.
- [5] Kompella, K.C. & M., Venu & R., Srinivasa. (2016). DWT based Bearing Fault Detection in Induction Motor using Noise Cancellation. *Journal of Electrical Systems and Information Technology*. 3. 10.1016/j.jesit.2016.07.002.
- [6] Irfan, M., Saad, N., Ibrahim, R., Asirvadam, V. S., Alwadi, A. S., & Sheikh, M. A. (2017). An Assessment on the Non-Invasive Methods for Condition Monitoring of Induction Motors. InTech. doi: 10.5772/67917
- [7] Sharma, Amandeep. (2015). A Review of Fault Diagnostic and Monitoring Schemes of Induction Motors. *International Journal for Research in Applied Science & Engineering Technology*. 3. 1145-1152.
- [8] Alwan, Hayder & Farhan, Noor & Sabbagh, Qais. (2017). Detection of Static Air-Gap Eccentricity in Three Phase induction Motor by Using Artificial Neural Network (ANN). *International Journal of Engineering Research and Applications*. 07. 15-23. 10.9790/9622-0705031523.
- [9] Stack, J., Habetler, T., & Harley, R. (2004). Effects of machine speed on the development and detection of rotor faults in induction machines. *IEEE Transactions on Industry Applications*, 40(5), 1260-1267.
- [10] Babu W, Rajan & C S, Ravichandran. (2015). Comprehensive review on fault detection in induction motor. 10. 43630-43634.
- [11] Tavner, P. J. (2008). Review of condition monitoring of rotating electrical machines. *IET Electric Power Applications*, 2(4), 215-247
- [12] Samanta, B., Al-Balushi, K. R., & Al-Araimi, S. A. (2003). Artificial neural networks and support vector machines with genetic algorithm for bearing fault detection. *Engineering Applications of Artificial Intelligence*, 16(7-8), 657-665.
- [13] Mohamedi, Walid. (2023). Application of vibration analysis for the diagnosis of rotating machines. 10.21203/rs.3.rs-3619043/v1. Jardine, A. K. S., Lin, D., & Banjevic, D. (2006). A review on machinery diagnostics and prognostics implementing condition-based maintenance. *Mechanical Systems and Signal Processing*, 20(7), 1483-1510.
- [14] Widodo, A., & Yang, B. S. (2007). Support vector machine in machine condition monitoring and fault diagnosis. *Mechanical Systems and Signal Processing*, 21(6), 2560-2574.
- [15] Randall, R. B., & Antoni, J. (2011). Rolling element bearing diagnostics—A tutorial. *Mechanical Systems and Signal Processing*, 25(2), 485-520.
- [16] Bellini, A., Filippetti, F., Franceschini, G., Tassoni, C., & Kliman, G. B. (2008). Advances in diagnostic techniques for induction machines. *IEEE Transactions on Industrial Electronics*, 55(12), 4109-4126.
- [17] Kliman, G. B., & Stein, J. (1990). Methods of motor current signature analysis. *Electric Machines and Power Systems*, 19(3), 567-585.
- [18] A. Almounajjed, A. K. Sahoo, M. K. Kumar and M. W. Bakro, "Condition Monitoring and Fault Diagnosis of Induction Motor - An Experimental Analysis," 2021 7th International Conference on Electrical Energy Systems (ICEES), Chennai, India, 2021, pp. 433-438, doi: 10.1109/ICEES51510.2021.9383729.
- [19] Mehala, Neelam. (2012). Current Signature Analysis for Condition Monitoring of Motors. *International Journal of Electronics and Computer Science Engineering*. 1.
- [20] Wang, Rongcai & Zhan, Xianbiao & Bai, Huajun & Dong, Enzhi & Cheng, Zhonghua & Jia, Xisheng. (2022). A Review of Fault Diagnosis Methods for Rotating Machinery Using Infrared Thermography. *Micromachines*. 13. 1644. 10.3390/mi13101644.
- [21] Cruz, Jonathan dos Santos and Silva, Raissa and Rittner, Leticia and Giesbrecht, Mateus, Fault Diagnosis of Induction Machines by Thermal Imaging Using Machine Learning: A Comparative Analysis. Available at SSRN: <https://ssrn.com/abstract=4682556> or <http://dx.doi.org/10.2139/ssrn.4682556>
- [22] Thomson, W.T. & Fenger, M.. (2001). Current Signature Analysis to Detect Induction Motor Faults. *Industry Applications Magazine*, IEEE. 7. 26 - 34. 10.1109/2943.930988.
- [23] Ahmed, Istiak & Ertugrul, Nesimi & Soong, W. (2005). A Study on the Detection of Fault Frequencies for Condition Monitoring of Induction Machines.
- [24] Turkmenoglu, M. A. V., & Aktas, M. (2010). Wavelet-based switching faults detection in direct torque control induction motor drives. *IET Science, Measurement and Technology*, 4(6), 303-310.
- [25] Xie, Y., & Zhang, T. (2015, November). A fault diagnosis approach using SVM with data dimension reduction by PCA and LDA method. In *2015 Chinese Automation Congress (CAC)* (pp. 869-874). IEEE.
- [26] Ali, M. Z., Shabbir, M. N. S. K., Zaman, S. M. K., & Liang, X. (2020). Single-and multi-fault diagnosis using machine learning for variable frequency drive-fed induction motors. *IEEE Transactions on Industry Applications*, 56(3), 2324-2337.
- [27] Bang, S. H., Ak, R., Narayanan, A., Lee, Y. T., & Cho, H. (2019). A survey on knowledge transfer for manufacturing data analytics. *Computers in Industry*, 104, 116-130.
- [28] He, S. G., He, Z., & Wang, G. A. (2013). Online monitoring and fault identification of mean shifts in bivariate processes using decision tree learning techniques. *Journal of Intelligent Manufacturing*, 24, 25-34.
- [29] Ting, S. L., Ip, W. H., & Tsang, A. H. (2011). Is Naive Bayes a good classifier for document classification. *International Journal of Software Engineering and Its Applications*, 5(3), 37-46.