



الجامعة
UNIVERSITI
TEKNOLOGI
MARA



PROCEEDINGS OF JOHOR INTERNATIONAL INNOVATION INVENTION COMPETITION AND SYMPOSIUM 2024 (JIICaS 2024)



*“Flourish and Nurturing Sustainable
Innovation for a Prosperous Nation”*

Editorial Board

Editors

NUR INTAN SYAFINAZ AHAMD

DR. HAJAH NORBAITI TUKIMAN

DR. NUR IDAYU ALIMON

AHMAD KHUDZAIRI KHALID

DR. MOHAMAD FAIZAL AB JABAL

DR. WAN MUNIRAH WAN MOHAMAD

DR. NUR SYAMILAH ARIFFIN

AZYAN YUSRA KAPI@KAHBI

NURHAZIRAH MOHAMAD YUNOS

NORZARINA JOHARI

AISHAH MAHAT

AZRINA SUHAIMI

HARSHIDA HASMY

DR. NG SET FOONG

FOO FONG YENG

Copyright © 2024 Universiti Teknologi MARA Cawangan Johor, Kampus Pasir Gudang, Jalan Purnama, Bandar Seri Alam, 81750 Masai Johor.

All extended abstracts published in this e-book have not been subject to JIIICaS2024 peer review or check. The authors are responsible for the contents of their extended abstracts and warrant that their extended abstract is original, has not been previously published, and has not been simultaneously submitted elsewhere. The views expressed in the abstracts in this publication are those of the individual authors and are not necessarily shared by the editor.

All rights reserved. No part of this publication may be reproduced in any form or by electronic or mechanical means, including information storage and retrieval systems, or transmitted in any form or by any means, without the prior permission in writing from the Course Coordinator of College of Computing, Informatics and Mathematics, Universiti Teknologi MARA Cawangan Johor, Kampus Pasir Gudang.

e ISBN: 978-967-0033-25-9



**Published in Malaysia by
Universiti Teknologi MARA Cawangan Johor
Kampus Pasir Gudang
81750 Masai**



Preface

In the name of Allah, the Almighty who gives us the enlightenment, the truth, the knowledge and with regards to Prophet Muhammad (peace be upon him) for guiding us to the straight path. We thank to Allah for giving us guidance and strength to write this e-book.

This e-book compiles the extended abstracts that submitted to Johor International Innovation Invention Competition and Symposium 2024 (JIIICaS2024), where JIIICaS2024 is a virtual platform for all creative minds to share and present their invention and innovation. Each abstract gives a brief background on the innovation or project.

We hope that this e-book will help the readers to get to know the innovation done by the students and get some ideas to develop future innovation products.



Foreword Rector



Assalamualaikum warahmatullahi Wabarakatuh,
Salam Sejahtera, Salam Malaysia MADANI and
Salam UiTM Dihatiku.

In the name of Allah, the Most Gracious, the Most
Merciful.

It is a great honor to welcome you to the Johor
International Innovation, Invention, Competition, and
Symposium 2024 (JIIICaS 2024). This event

connects various disciplines, focusing on education and engaging educators,
students, researchers, and innovators from all walks of life.

Innovation is not just about ideas; it demands perseverance, creativity, and
determination to turn those ideas into reality. The remarkable projects
showcased today highlight the dedication and spirit of all participants.
Initiatives like this not only explore new technologies but also cultivate skills
and leadership among our youth. At Universiti Teknologi MARA (UiTM) Johor
Branch, we are fully committed to fostering a dynamic culture of innovation,
promoting the commercialization of new products, and encouraging
meaningful collaborations with industry and society.

As we celebrate this event, I would like to extend my heartfelt gratitude to all
sponsors, judges, the College of Computing, Informatics and Mathematics,
UiTM Pasir Gudang Campus as the event organizer, as well as to the
researchers and participants for their hard work in making this event a
success. Let us continue striving for innovation and excellence. May the
ideas presented today inspire us and lay the groundwork for future
achievements.

Thank you.

Associate Professor Dr. Saunah Zainon
Rector
Universiti Teknologi MARA (UiTM)
Johor Branch

(A-ST028) BLYNK ACTIVATED SOLAR PANEL SHINER USING ESP32 AS MICROCONTROLLER

Mohd Imran Noor Hisam, Fadila Mohd Atan, Nur Asfahani Ismail

Electrical Engineering Studies, College of Engineering, UiTM Johor Branch, Pasir Gudang Campus

Corresponding author: fadila2533@uitm.edu.my

ABSTRACT

Solar energy refers to the process of using photovoltaic (PV) panels to convert solar energy into electricity, either directly or indirectly. Most of the energy we use on Earth originates from clean, renewable sources, with solar energy being at the forefront due to its environmentally friendly attributes. It has gained global recognition as an effective and sustainable method for generating power. Although considerable research efforts are focused on maximizing the energy derived from sunlight, there are significant challenges, such as dust accumulation on solar panels and air pollution. These issues can lower the energy output from solar cells by over 25% to 40% in various regions, especially in tropical countries like India. To maintain optimal solar energy production, regular cleaning of solar panels is crucial. Automated solutions like robotic cleaners are emerging as a key technology to streamline this maintenance process, saving time and reducing the need for manual labour. The objective of this paper is to design a smart solar panel cleaning system that automatically cleans the PV panels using a combination of water spray and a brush to remove dirt and debris. The system relies on the ESP32 microcontroller to operate components like DC motors and ultrasonic sensors, ensuring thorough cleaning. The use of the ESP32 microcontroller allows for efficient data transmission and control between the different system components. This project has been proven to be fully functional with the development of prototype to evaluate the system's performance in real-world conditions.

Keywords: Blynk, ESP32, IoT, solar panel shiner.

1.0 INTRODUCTION

The rapid growth of solar energy as a primary source of renewable power has underscored the importance of maintaining the efficiency of solar photovoltaic (PV) panels. As these panels are typically installed outdoors, they are susceptible to dust, dirt, and other environmental contaminants that can significantly hinder their performance. Research indicates that even a thin layer of dust can reduce solar energy output by up to 25%, leading to substantial losses in energy production and, consequently, financial returns for solar energy users. To address this pressing issue, the development of an automated solar panel cleaning system has emerged as a viable solution. This innovation leverages advanced technologies, including the ESP32 microcontroller and various sensors, to create a smart cleaning mechanism that operates autonomously. By integrating Internet of Things (IoT) capabilities, the system not only enhances the cleaning process but also allows for remote monitoring and control via a smartphone application.

The motivation behind this innovation stems from the need to optimize solar energy production while minimizing the labour and resources required for manual cleaning.

Traditional cleaning methods are often labour-intensive, costly, and can pose safety risks, especially in large solar farms. By automating the cleaning process, this invention aims to ensure that solar panels remain in peak condition, thereby maximizing their energy output and contributing to the broader goal of sustainable energy utilization. This project represents a significant step towards enhancing the efficiency and reliability of solar energy systems, ultimately supporting the transition to a greener future.

2.0 OBJECTIVE

- 1.To build a prototype of Solar Shiner cleaning system using ESP 32 as microcontroller
- 2.To analyse the effectiveness of Solar Shiner cleaning system to maintain the cleanliness of the solar panel surface in maximizing their energy production under sun exposure.

3.0 METHODOLOGY

The system is built around an ESP32 microcontroller as shown in Figure 1, which serves as the brain of the operation, enabling real-time monitoring and control. It is equipped with various sensors, including ultrasonic sensors for distance measurement, a water level sensor to optimize water usage, and dust sensors to detect the accumulation of dirt on the solar panels. The cleaning mechanism consists of brushes and a DC water pump that work together to remove dust and debris effectively. Additionally, the system integrates IoT capabilities, allowing users to control and monitor the cleaning process remotely via a smartphone application. This feature enhances user convenience, enabling them to initiate cleaning cycles or check the status of the system from anywhere.

The final phase involved prototype development, testing and evaluation. The prototype was constructed using the selected components, and rigorous testing was conducted under various environmental conditions to assess its effectiveness. Performance metrics, such as the amount of dust removed and the increase in energy output from the solar panels, were measured to evaluate the system's efficiency. Data analysis was performed to establish the correlation between the automated cleaning process and the solar panels' energy production, providing valuable insights into the system's overall performance and effectiveness in maintaining solar panel cleanliness.

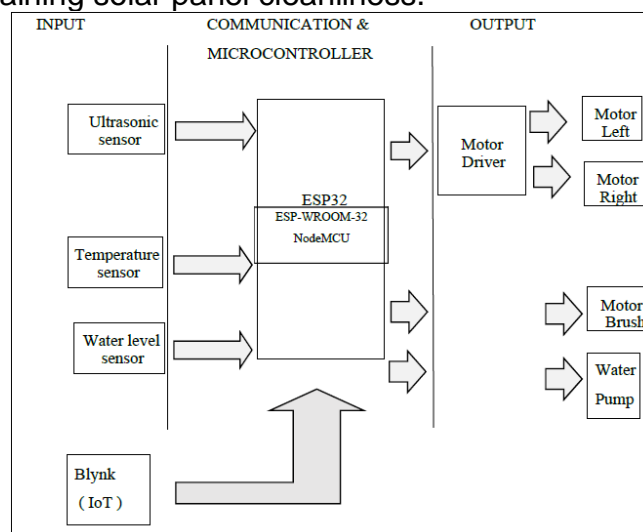

Figure 1: Block diagram of Solar Panel Shiner using ESP32

4.0 RESULTS

The automated Solar Panel Shiner system offers significant advantages and innovations in the renewable energy sector. By automating the cleaning process, it effectively enhances solar panel efficiency by keeping them free from dust and debris, leading to higher energy output and reduced operational costs. The integration of IoT technology enables remote monitoring and control, allowing for real-time updates and proactive maintenance, which further optimizes energy production and user convenience. The system's novelty lies in its use of advanced technologies, such as the ESP32 microcontroller and ultrasonic sensors, which create a smart, adaptive cleaning solution that operates independently of human intervention. This innovative approach sets a new standard for solar panel maintenance, contributing to greater sustainability and safety in the renewable energy industry.

5.0 CONCLUSION

Overall, the automated solar panel cleaning system represents a notable progress in the upkeep of solar energy technology. Given the increasing importance of solar power as a primary source of renewable energy, it is essential to prioritize the attainment of maximum efficiency in solar panels. This project effectively showcases the efficacy of an intelligent cleaning solution, which utilizes an ESP32 microcontroller and sophisticated sensors, in efficiently addressing the build-up of dust and debris. The system's IoT features allow for remote monitoring, resulting in decreased labour expenses and minimized safety hazards, while simultaneously improving user convenience. This innovation is notable for its practicality and creativity, leading to more effective and environmentally friendly solar panel maintenance techniques. Additionally, it establishes the foundation for future investigation and advancement in automated cleaning technology, facilitating the shift towards a more environmentally friendly future.