

# E-BOOK OF EXTENDED ABSTRACT

## THE 14<sup>TH</sup> INTERNATIONAL INVENTION, INNOVATION & DESIGN COMPETITION 2025



14<sup>TH</sup> **INDES** 2025

ENVIRONMENTAL • SOCIAL • GOVERNANCE



# **E-BOOK OF EXTENDED ABSTRACT**

THE 14th INTERNATIONAL  
INVENTION, INNOVATION &  
DESIGN COMPETITION 2025

**Organized by:**

Office of Research, Industry,  
Community & Alumni Network  
UiTM Perak Branch

**© Unit Penerbitan UiTM Perak, 2025**

All rights reserved. No part of this publication may be reproduced, copied, stored in any retrieval system or transmitted in any form or by any means; electronic, mechanical, photocopying, recording or otherwise; without permission on writing from the director of Unit Penerbitan UiTM Perak, Universiti Teknologi MARA, Perak Branch, 32610 Seri Iskandar Perak, Malaysia.

Perpustakaan Negara Malaysia

Cataloguing in Publication Data

No e- ISBN: 978-967-2776-52-9

Cover Design: Dr. Mohd Khairulnizam Ramlie

Typesetting : Georgia

# **EDITORIAL BOARD**

## **Editor-in-Chief**

MUHD SYAHIR ABDUL RANI

## **Managing Editors**

NUR FATIMA WAHIDA MOHD NASIR

SYAZA KAMARUDIN

NORASYIKIN ABDUL MALIK

## **Copy Editors**

SHEEMA LIZA IDRIS

AZURAWATI ZAIDI

HALIMATUN SAADIAH ABD MUTALIB

HALIMATUSSAADIAH IKSAN

IZA FARADIBA MOHD PATEL

MOHAMAD SAFWAT ASHAHRI MOHD SALIM

MUHAMMAD WAJIHUDDIN JOHARI

NAZIRUL MUBIN MOHD NOOR

NORAZIAH AZIZAN

NOOR AILEEN IBRAHIM

NOOR FAZZRIENEE JZ NUN RAMLAN

NOORLINDA ALANG

NURAMIRA ANUAR

NURDIYANA MOHAMAD YUSOF

NURSHAHIRAH AZMAN

NURUL FARHANI CHE GHANI

NURUL MUNIRAH AZAMRI

ONG ELLY

PAUL GNANASELVAM

SITI SYAIRAH FAKHRUDDIN

WAN FARIDATUL AKMA WAN MOHD RASHDI

WAN NURUL FATIHAH WAN ISMAIL

ZARLINA MOHD ZAMARI

AMIRUL FARHAN AHMAD TARMIZI

IMRAN TORIQ

# ERGONOMIC DESIGN OF A MULTIPURPOSE PORTABLE MORTAR MIXER FOR TILING WORKS

Farrah Rina Mohd Roshdi<sup>1</sup>, Mohd Zulhilmi Ab Kadir<sup>2</sup>, Muhammad Aiman Zulkarnain Zamri<sup>3</sup>, Amirul Danial Mohd Zahir<sup>4</sup>, and Muhammad Amirun Hisyam Mohd Nor<sup>5</sup>

<sup>1</sup>Faculty of Built Environment, Universiti Teknologi MARA, Perak, Malaysia  
<sup>2-5</sup>Program Teknologi Pembinaan, Kolej Vokasional Alor Setar, Kedah, Malaysia

*farrahrina@uitm.edu.my*

## ABSTRACT

The Multipurpose Portable Mortar Mixer for Tiling Works project seeks to design and build a portable mortar mixer to enhance efficiency and productivity within the construction sector. The mixer is specifically engineered to streamline modest construction tasks at job sites, minimising the time and labour needed for manual mortar mixing. Furthermore, it seeks to offer a pragmatic answer to mobility challenges in areas with constrained space or challenging accessibility. The tool's design considers numerous critical criteria, including stability, reliability, and user-friendliness, while employing lightweight yet robust materials, such as aluminium and durable plastic, to guarantee long-term efficacy and longevity. An efficient hand drill mechanism powers the mixer, while the ergonomic design guarantees ease of use for users across diverse working environments. The development process encompasses market research, material selection, and efficiency testing to verify that the instrument satisfies practical requirements in real-world applications. This initiative aims to enhance productivity and decrease labour costs in the construction sector, particularly for small and medium-sized projects. This mobile mortar mixer is anticipated to be an innovative solution that addresses the limitations of traditional construction equipment, which necessitates extensive area and substantial personnel.

**Keywords:** portable, mortar mixer, tiling works, ergonomic design, static posture

## 1. INTRODUCTION

This mixer machine is termed portable due to its ease of operation and transportability. The components consist of features of a water pipe that facilitate the smooth flow of water and ensure precise measurements during mortar mixing. This machine is additionally fitted with a funnel tube at the bottom for the passage of mortar during tile installation tasks ergonomically suited to workers or labour. The ergonomic design for this machine was to minimise the static posture whereby a fixed position, with minimal movement of the body parts that can fatigue muscles in a short duration. The utilisation of an enhanced drill facilitates the mixing of mortar to achieve superior quality ergonomically. This concept originated from observing the workers or labour struggling with tile installation, a task that demanded considerable labour and an extended timeframe for project completion. The labour was required to await the mixing of the mortar and thereafter utilise a trolley to convey the prepared heavy materials for mortar to the project location. Therefore, the enhancements implemented have rendered the installation of tiles more efficient and expedient using the Ergonomic Portable Mortar Mixer. This equipment is quite lightweight compared to current mortar mixing machines. This innovation products may be effortlessly relocated during operation due to its wheels.

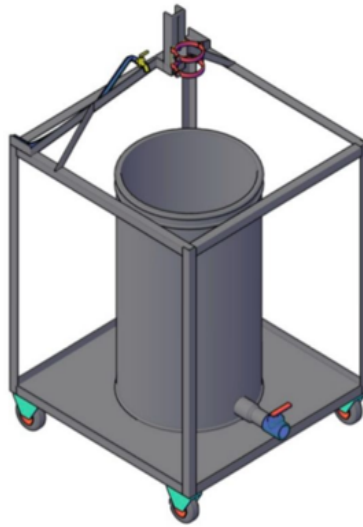

**Figure 1** Ergonomic design of a multipurpose portable mortar mixer for tiling works

## **2. METHODOLOGY**

Examine pertinent sources, such as journal articles, patents, and technical reports, to comprehend contemporary technology and the newest advancements in mixer design. Secondly, employing survey or interview methodologies with tile mixer users to ascertain their requirements, obstacles, and recommendations for improved machine designs. Third, perform a comparative analysis of current machine technical specifications. Fourth, Preliminary Design and Conceptual Design of the portable mortar mixer are formulated by considering dimensions, weight, capacity, mixing efficiency, and portability. Lastly, generate a simulation via observation and analysis utilising design software like Computer Aided Design (CAD) to create a machine model. Execute simulations to evaluate the design's performance concerning critical criteria, including stability, durability, and mixing efficiency.

## **3. FINDINGS**

The illustration depicts the percentage of responders corresponding to the eighth question. The survey results indicate that 86.7 percent of respondents affirmed that the machine operates effectively and meets the project specifications. Only 13.3 percent answered “No,” signifying that there is still potential for enhancement.

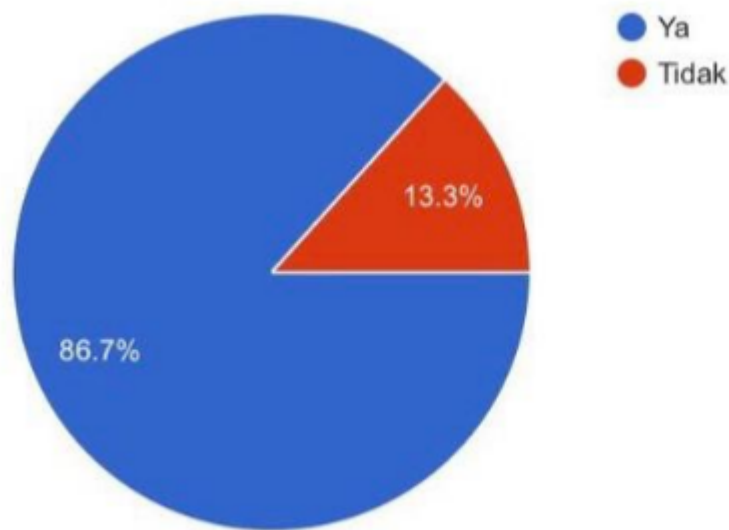

**Figure 2** Machine usability and simulation

#### **4. CONCLUSION**

The Multipurpose Portable Mortar Mixer for Tiling Works is an innovative solution aimed at addressing challenges associated with the manual mixing of materials, particularly in tile installation tasks. This device is engineered with portability, lightweight construction, and energy efficiency to assist users, including construction workers. The Multipurpose Portable Mortar Mixer for Tiling Works, with an ergonomic design focusing on eliminating static posture while work is carried out and robust materials, enhances job efficiency, conserves time, and alleviates the user's physical strain. This product is developed through needs research, design, prototype creation, and field testing to satisfy user requirements and guarantee optimal performance. The Multipurpose Portable Mortar Mixer for Tiling Works is an effective and unique solution that enhances the efficiency and quality of operations in the construction sector.

#### **REFERENCES**

Raghul Anandh, K. S., Sankar, S., & D., M. (2022). A review on tools and methods applied to enhance ergonomics in the construction industry. *Nucleation and Atmospheric Aerosols*. <https://doi.org/10.1063/5.0102960>

E-Book of Extended Abstract THE 14th INTERNATIONAL INVENTION, INNOVATION &  
DESIGN COMPETITION 2025

e ISBN 978-967-2776-52-9

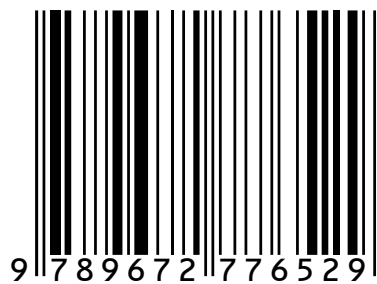

Unit Penerbitan UiTM Perak

(online)