

# FPGA-Based GUI Control using LCD Touch Screen

Mohd Zulfadli B Farid Wajdee  
Faculty of Electrical Engineering,  
Universiti Teknologi MARA (UiTM),  
40450 Shah Alam, Malaysia.  
*Zul\_88palai@yahoo.com*

**Abstract** –*This paper describes a design of FPGA Based GUI (Graphical User Interface) control system using LCD touch screen. Now a day, many gadgets are using touch screen technology as their prospect to attract user. Touch screen is easy to use and more intuitive of computer interface since it allows user to navigate a system by touching icon or links on the screen without having to use mouse or keyboard. In this project, four application such as turning on LED, displaying instruction on LCD display, seven segment display and showing picture using icon are tested and programmed are written in Hardware Description Language(HDL) and LTM Touch Screen is used as the command panel.*

**Keywords** – *Field Programmable Gate Array (FPGA), Liquid Crystal Display(LCD), LCD Touch Screen, QuartusII.*

## I. INTRODUCTION

Touch Screen technology becomes more popular in recent year. This technology is still widely used in many electronic devices such as smart phone, iPad, tablet computer and game consoles. In medical field and heavy industry, touch screen become more popular because icon or pictures are used as menu driven instead of keyboard or mouse. In the world at fingertips, internet users are exposed every year to a lot of gadgets with touch screen technology. For a new generation, touch screen are more interactive and useful not only for video game activity but in learning process.

Touch screen technology begins in 1965 with E.A Johnson describes his work on capacitive touch screens in a short article before it is used with photograph and diagram in 1967[1]. Touch screen technology then develop a year by year by many researchers and engineers in company such as Siemens Corporation, Apple, Microsoft and others.

Traditionally, electronic device such as a button or switch is used to control and activate something. But with the availability of LCD touch screen, these button or switches can be replaced with iconic image which represents an instruction or menu of any system. In 2007 and 2008 Korea Institute of Science and Technology (KIST) obtain that user feel they can manipulate GUI with a cue (icon) because it more comfortable compare to mechanical button [2]

Thus, this project aims to design GUI control using LCD touch screen which can control component based on the given menu. Touch screen technology is considered since it is portable, user friendly and has low power consumption. A GUI control system is able to activate LEDs, LCD, seven segments on the Altera DE2 Development Board and it able to change a picture when user touches a specific area in the menu at LTM touch screen.

## II. GUI Control System

The components and software needed to design the GUI control system are described as follows:

### A. FPGA

Field Programmable Gate Array (FPGA) is semiconductor device that can be programmed after manufacturing [3]. Before FPGA logic circuits were built at the board level using standard component or at the gate level in expensive application-specific (custom) integrated circuits [4]. FPGA is called “field-programmable” and it allow user to program product features and function by connecting the cell using interconnected wires and switches. FPGA have a big advantage of microprocessor in term of performance and usage [5]. Because of that, FPGA can perform complex combination function (logics elements “LEs”).

Cyclone II is processor of DE2 board. The Cyclone II gives high performance and have low power consumption at the cost that rivals that of ASICs[6].The principle of ALTERA DE2 is to provide ideal vehicles for advanced design prototype in the multimedia, storage and networking. It also uses state-of-the-art technology in both hardware and CAD to expose designer to a range of topic [7].

### B. LCD Touch Screen

LCD touch screen is a device that can produce a graphical and can detect the location of touch within specific area. The LCD can be categorized to 3 types on sensing mechanism which are surface acoustic wave touch screen, resistive touch screen and infrared touch screen[8].The resistive touch screen is mostly used in mobile because it does not require the additional devices. When the force on the touch screen is given with hand, it is tough to specify the location exactly by subtle movements of hand. The touch screen LCD module is a hardware that consists of three elements: LCD graphical data interface, touch screen interface and LCD controller interface [9].

LCD touch panel used in this project is TERASIC LTM which provides 800x480 full-color high quality LCD touch panel.[10]

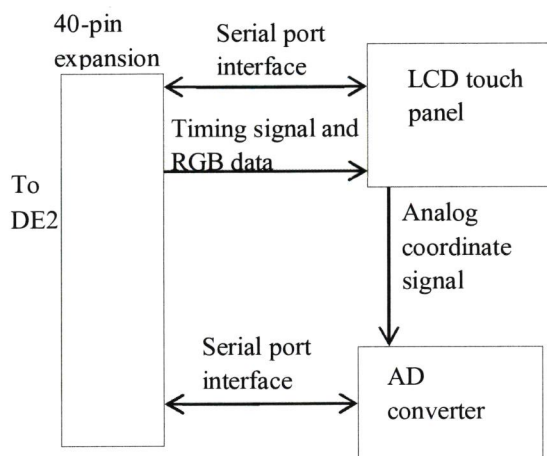

Fig.1: the block diagram of LTM

Figure 1 shows the block diagram of LTM. The LTM consists of three major components: LCD touch panel module, AD converter, and 40-pin expansion header. All of the interfaces on the LTM are connected to Altera DE2 board via the 40-pin expansion connector. LCD touch panel controls a serial port interface and receives synchronous timing signal and RGB data from DE2 board. AD converter

is used to convert the coordinates of touch point and its corresponding digital data and output to the FPGA via expansion header[11].

### C. QuartusII

Altera QuartusII design software provides a complete, multiplatform design environment that easily adapts to specific design needs. It is a comprehensive environment for system-on-a-programmable-chip (SOC) design. The QuartusII software includes solutions for all phases of FPGA and CPLD design [12].

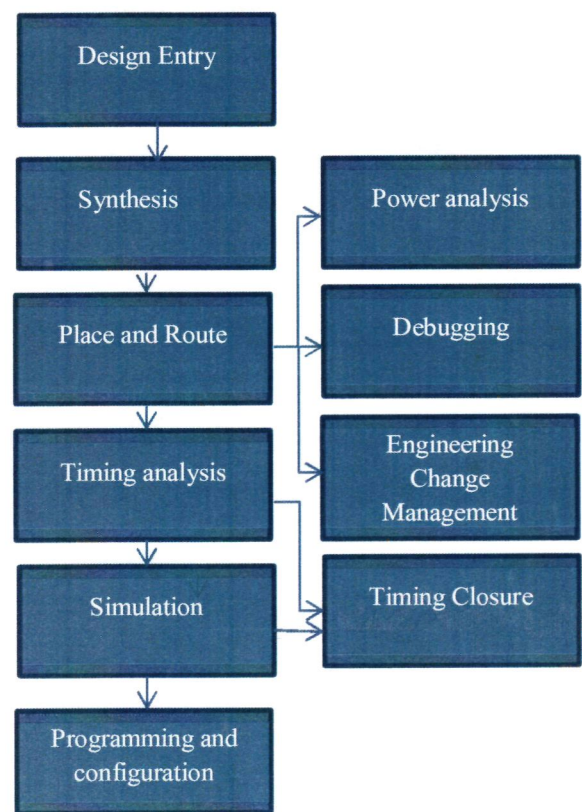

Fig.2: QuartusII design flow

At design entry, designs files created using Verilog. This Verilog design files can contain any combination of QuartusII support constructs and can be combined them with other type of design files in a hierarchical design. Synthesis tools are used to synthesize Verilog HDL and VHDL design files and then they generates Edit netlist file(.edf) or Verilog Quartus Mapping file(.vqm). Place and route consists of power analysis, debugging and engineering change management. It assigns each logic function to the



best logic cell location for routing and timing and selects appropriate interconnection paths and pin assignments. Programming and configuration is a final method in design before implementing to FPGA or any hardware.

### III. METHODOLOGY

#### I. SOFTWARE DESIGN

This section discusses about the method in developing the GUI command using QuartusII software.

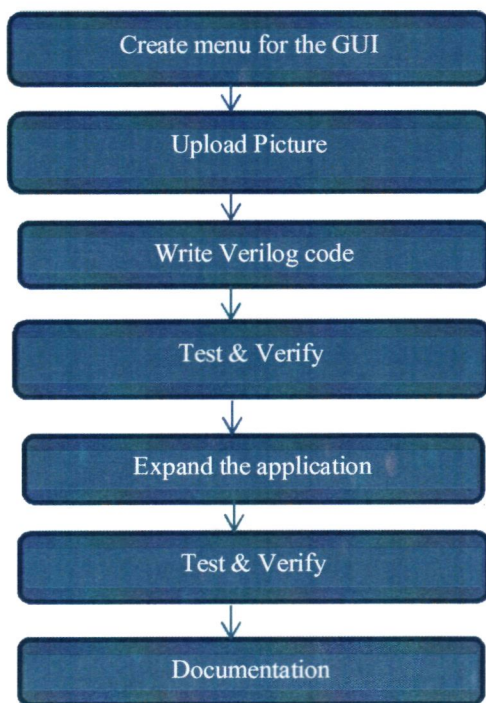

Fig3.1: Flow chart software design

Figure 3.1 shows the steps to be taken in designing the software. To create menu for the GUI, every coordinate on the panel is considered and it is very important. Four blocks for each application are created by drawing the picture as shown in figure 3.2 before considering the coordinates x and y.

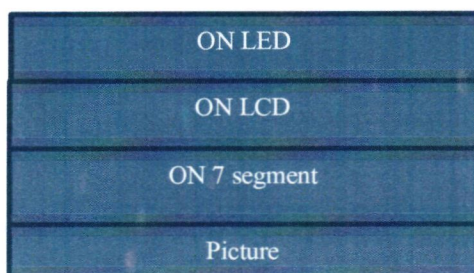

Fig3.2: Menu for a GUI

To upload the picture into flash using Altera DE2 we need to know the size of the panel and the picture. In this case the picture has size of height=800, width=400 and its format is in 24 bit bmp. Then the USB-Blaster is connected to PC and the control panel bit stream is loaded into FPGA as shown in Figure3.3.

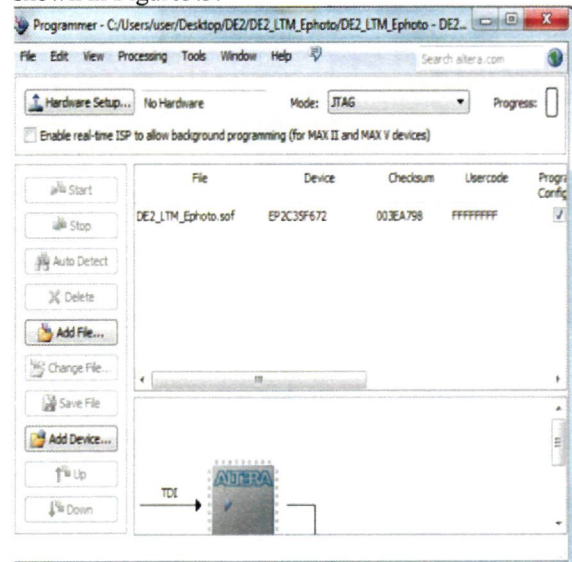

Fig3.3: Programming window

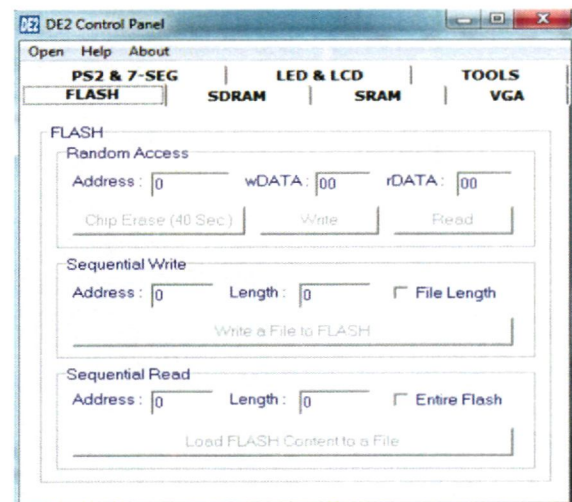

Fig3.4: DE2 control panel window

Once the control panel stream is programmed into FPGA, the application software as shown in the Figure 3.4 is displayed. The FLASH is chosen and erased before new file is written into the Flash. The menu/icon is stored in the Flash and they

displayed in LCD touch screen when selected command is touched.

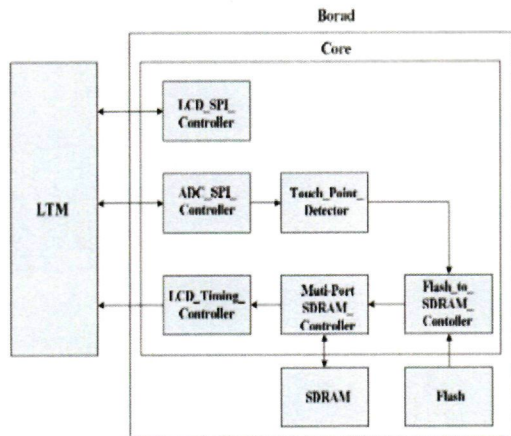

Fig3.5: Block diagram of the Ephoto demonstration

The third step is writing Verilog code for controller which can interface between LEDs with touch panels. To control the touch panel, we must know the coordinate of choosing area. From Figure 3.5, the touch panel (LTM) will convert analog signal to digital signal. So from the signal it will produce X and Y-coordinate to the touch panel detector. To control LED, we must know the coordinate and know the behavior of LED. LED is ON if we give a high level logic. So, we can connect direct from the touch point detector to LED. In order to test the system, 18 LEDR are chosen to be activated.

A next step is test and verifying the system. It is done by opening program device (open programmer) and the USB ports are connected in hardware setup. After starting the program, it should display the picture in the LTM and if we touch in specific area it will turn on the LED. Figure 3.6 shows the parameter used in identifying the coordinate for each of applications.

No	Control\ Coordinate	XBD1	XBD2	YBD1	YBD2
#1	LED ON	B61	FFF	000	FFF
#2	LCD ON	70F	B61	000	FFF
#3	7SEG ON	300	70F	000	FFF
#4	PHOTO	000	300	000	FFF

Fig3.6: The parameter used in Touch panel

## II. Controller Program

The functionality is important to meet the objective in design. In an embedded system a microcontroller

acts like a brain which is controls the whole system. Figure 3.7 shows a flowchart for controller.

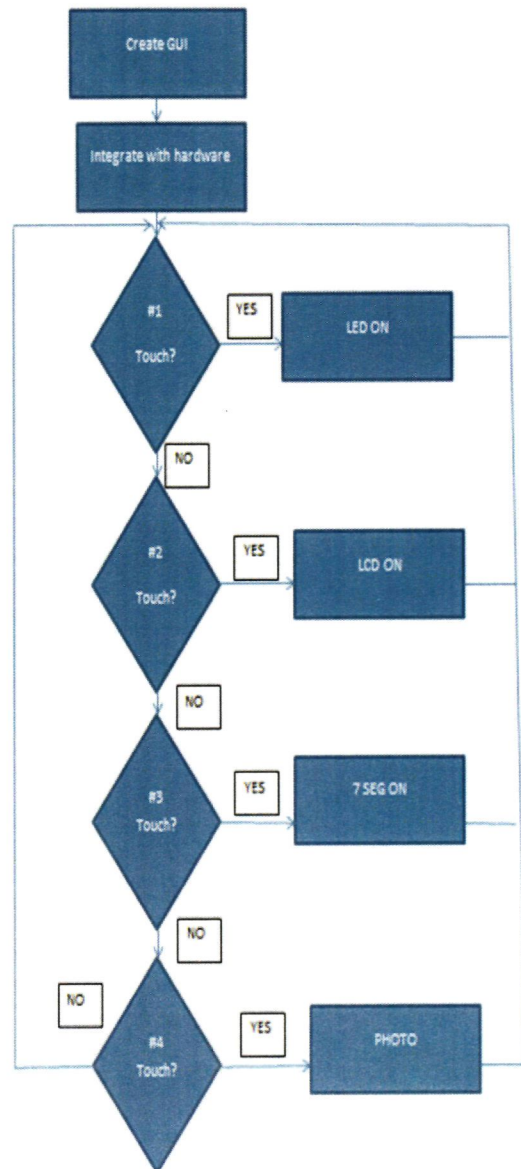

Fig3.7: Flowchart for controller

After creating the GUI using QuartusII software another Verilog module, controller, has to be created in order to control which application has to be activated when certain area is touched. At the LTM, we have identified 4 parameters to represent the command. There are parameters 1 for LED, parameter 2 for LCD, parameter 3 for seven segments and parameter 4 for change photo.



### III. Hardware Implementation

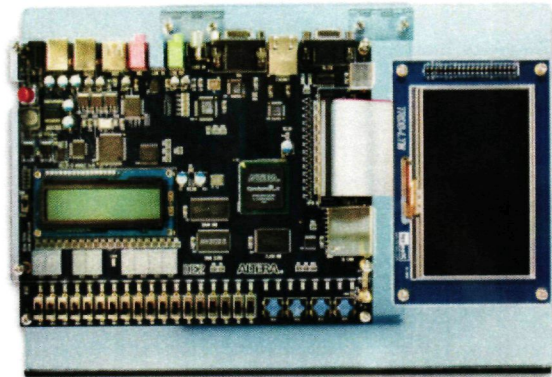

Fig3.8: The DE2 board and LTM Terasic

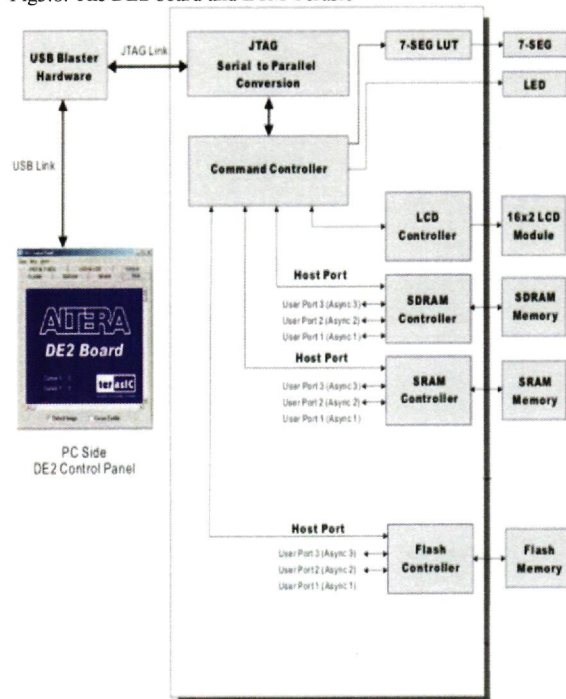

Fig3.9: Schematic of controller

Figure 3.8 shows the connection between DE2 board and LTM Terasic. It is connected by IDE cable and has extension (PIO). DE2 boards have 18 pin LEDR, 8 LEDG, 8 seven segments and LCD display.

Figure 3.9 shows the connection from DE2 board through PC side. USB blaster hardware is the medium between PC and DE2 board. The program code and picture are uploaded from the PC to the controller. The controller connects directly to LED, 7-seg LUT, LCD controller, SDRAM controller, SRAM controller and Flash controller.

### IV. RESULTS

#### A. Synthesized block for the system

In this project we have created 9 modules and each module has its own function as described in the following table 4.1.

Table1: Module in design system

Module	Description
<p>lcd_spi_controlleru1</p>	-Control LCD display function. Uses serial port interface to communicate with the LCD driver IC.
<p>adc_spi_controlleru2</p>	- Receive analog signal from LCD and will convert the signal into digital signal.
<p>touch_point_detectoru3</p>	- Determine the coordinate x and y either photo, LED, LCD and 7 segments to be selected.
<p>flash_to_sdramu4</p>	- Read RGB data of one picture stored in the Flash, and then write data into SDRAM buffer. With this module the picture will change after it activated.

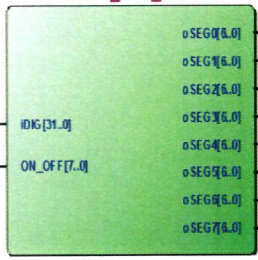
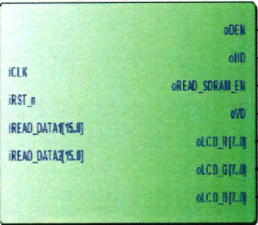
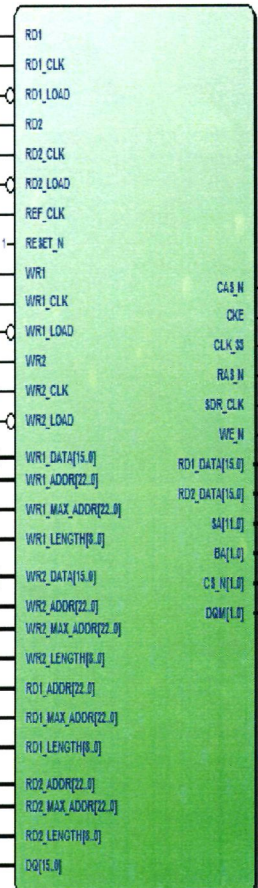
Module	Description
<p><b>SEG7_LUT_8:u5</b></p> 	<p>-Control seven segments. It have 8 output which is we can control 8 seven segments. iDIG show the position in touch screen area.</p>
<p><b>lcd_timing_controller:u8</b></p> 	<p>-Control the timing of LCD. It receive a signal from SDRAM and will maintain the picture appear in LTM touch screen until it receive another signal.</p>
<p><b>Sdram_Control_4Port:u7</b></p> 	<p>-Store picture data and control all the activity in the circuit. It can read or write and will give signal to Flash and LCD timing.</p>

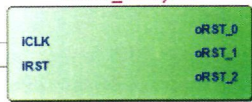
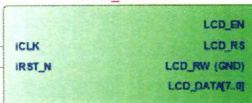
Module	Description
<p><b>Reset_Delay:u8</b></p> 	<p>-Produce a reset signal to the circuit.</p>
<p><b>LCD_TEST:u9</b></p> 	<p>-Control LCD in term of data, reset read/write and enable LCD.</p>

### B. Experiment Result

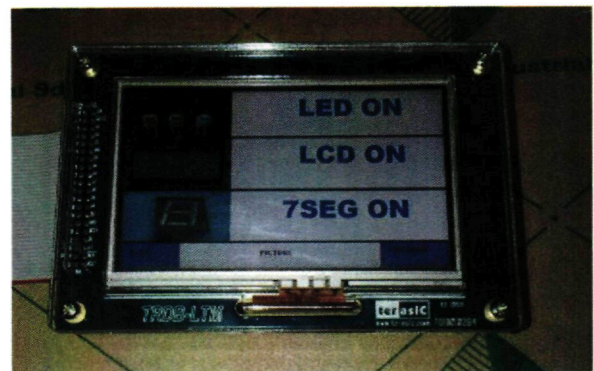

Figure 4.2 : Picture of LTM menu

Figure 4.2 shows the menu display on LTM touchscreen. It contains 4 instructions which are LED ON, LCD ON, 7 SEG ON and PICTURE and the results are shows at table2.

### TimesQuest clock analysis

Figure 4.3 show the graph slack Sdram in clock analysis at clk[0]. It shows that the higher edges are between slack 6.562ns to 6.498ns and lowest edges are between slack -3.088ns to -2.702ns.

Refer to the equation 1, clock slack time is depend on data arrival and data required. The different between higher edges and lowest edges slack is determining in hold relationships.

The TimeQuest analyzer performs two hold checks for each setup relationship. The first hold check determines that the data launched by the current launch edge is not captured by the pervious latch edges. The second hold check determines that the data launched by the next launched edge is not captured by the current latch edges.



Clock Setup Slack Time = Data Arrival Time –  
Data Required Time

Data Arrival Time = Launch Edge +  
Clock Network Delay to Source Register +  
Register to Pin Delay

Data Required Time = Latch Edge +  
Clock Network Delay to Destination Register –  
Output Delay Pin

Equation [1]

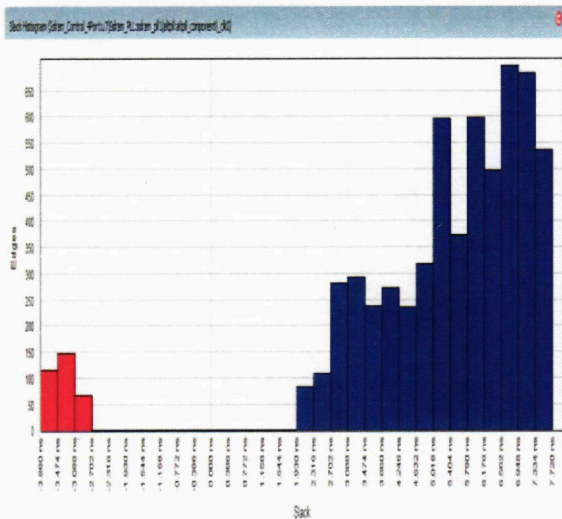

Figure 4.3: Graph slack histogram

Flow Summary	
Flow Status	Successful - Wed Jul 10 18:00:57 2013
Quartus II 32-bit Version	12.1 Build 243 01/31/2013 SP 1 S3 Web Edition
Revision Name	DE2_LTM_Ephoto
Top-level Entity Name	DE2_LTM_Ephoto
Family	Cyclone II
Device	EP2C35F672C6
Timing Models	Final
Total logic elements	1,617 / 33,216 ( 5 % )
Total combinational functions	1,284 / 33,216 ( 4 % )
Dedicated logic registers	1,082 / 33,216 ( 3 % )
Total registers	1082
Total pins	425 / 475 ( 89 % )
Total virtual pins	0
Total memory bits	28,672 / 483,840 ( 6 % )
Embedded Multiplier 9-bit elements	0 / 70 ( 0 % )
Total PLLs	1 / 4 ( 25 % )

Figure 4.2: Flow summary

Figure 4.2 show the flow summary, it has 1,284 combination functions and total pins are 425.

Table2: instruction and result picture

Instruction	Result
LED ON	
LCD ON	
7SEG ON	
PICTURE	

## V. CONCLUSION

This project design has successfully achieved the objectives of the project. The system able to active other device such as LED, LCD and seven segments using LCD touch screen and it also can display the picture in LCD touch screen. This project needs troubleshooting and testing of hardware and software continuously to achieve expected result. The main problem of this project is developing the program and software. For programming, right command of touch area must be chosen correctly in order to enable icon and also display picture. For software development, the main challenges are design the button and display the picture. To achieve this project, deep understanding and research must be done within period of final year project. Moreover, this project has potential to be developed further in the other applications in the future. It also can be upgraded to another function such as communication and wireless control.

#### IV. REFERENCES

- [1] E.A Johnson , 1965, Royal Radar Establishment, Malvern,UK, [inventors.about.com/od/tstartinventions/a/Touch-Screen.htm](http://inventors.about.com/od/tstartinventions/a/Touch-Screen.htm), touch screen technology for air traffic control in an article ,1968.
- [2] Ki-Uk Kyung, Jun-Young Lee and Mandayam A. Srinivasan, "Precise Manipulation of GUI on a Touch Screen with Haptic Cues" Third Joint Eurohaptics Conference and Symposium on Haptic Interfaces for Virtual Environment and Teleoperator Systems Salt Lake City, UT, USA, March 18-20, 2009.
- [3] Altera Cooperation, "FPGAs", [www.Altera.com/products/fpga.html](http://www.Altera.com/products/fpga.html) , 1995-2012
- [4] Andraka Consulting Group Inc, "Basic FPGA", [www.andraka.com/whatisam.htm](http://www.andraka.com/whatisam.htm), 16 MAC 2007..
- [5] Hasamnis, M.A., "Custom Hardware Interface using NIOS II Processor through GPIO", Industrial Electronics and Applications (ICIEA), 2012 7th IEEE Conference on, 18-20 July 2012.
- [6] Altera Cooperation, "Cyclone II FPGAs at Cost That Rivals ASICs", <http://www.altera.com.my/devices/fpga/cyclone2/cy2-index.jsp> , 1995-2012
- [7] Terasic Technologies Inc, "LCD Touch Panel Package", <http://www.terasic.com.tw/cgi-bin/page/archive.pl?Language=English&CategoryNo=68&No=213&PartNo=1>,2003-2012.
- [8] Sang Jun Lee, Seung Hun Jin, Jae Wook Jeon, "FPGA based auto focus system using touch screen", Seoul, Korea, August 20-22,2008.
- [9] Altera Cooperation, "implementing an LCD controller ,ver1.0, application note 527", MAY 2008.
- [10] Terasic Technologies Inc, "Altera DE2-115 Development and Education Board", <http://www.terasic.com.tw/cgi-bin/page/archive.pl?No=502>, 2003-2012.
- [11] Terasic Technology Inc, "LTM user manual" , [www.terasic.com](http://www.terasic.com) , 2003-2012.
- [12] Altera Corperation, "QuartusII Handbook Version 12.1, Volume 1:Design and Synthesis", November 2012.