

Battery Storage Design for Stand-Alone Room Lighting Powered by Wind Energy

Muhammad Khudri Bin Halim Bashah
Faculty of Electrical Engineering
Universiti Teknologi Mara
40000 Shah Alam, Malaysia
mat_xt7boys@yahoo.com

Abstract— The energy storage battery required for room lighting powered by wind energy system. The battery storage system which makes its integration with vertical blade wind energy system for power supplied that controlled by charge controller. The main focused is the integration of a battery storage system with room lighting during wind speed variation at different room size. This paper focus on design prototype system for stand-alone room lighting in the room with a blade, DC generator, charge controller, Battery storage and load.

Keywords- lead acid battery, storage system, charge, wind energy, room lighting

I. INTRODUCTION

Many remote communities are supplied with electrical energy produced by diesel generators. In many of these communities, the cost of energy is largely determined by the landed cost of the diesel fuel. The urgent need to reduce the cost of energy has led to the investigation of the use of renewable energy sources, such as the wind, to replace some or all of the fuel consumed. The small wind turbines in conjunction with battery storage, can replace the electrical energy produced by diesel generators in electrical applications [1]. Wind Power has been the fastest growing energy in the developed countries across the globe due to its increasingly attractive economics, its substantial environmental advantages and supportive energy policies [2]. Wind resources are good alternatives to provide energy power. Winds are also the most available renewable energy resources.

Wind is a readily available and renewable source of power. Small wind energy conversion systems have the potential to replace the current power source for battery charging systems [3]. Many types of new battery energy storage systems suitable for large-scale energy storage applications have been under development. Since 1985, Sumitomo Electric Industries has developed redox-flow batteries in collaboration with Kansai Electric Power Co. [4-5].

The stand-alone room lighting powered by wind energy should be used to replace the old system that can provide a better renewable energy and high efficiency of using energy. This stand-alone room lighting powered by wind energy is build with a battery storage system to provide a high quality of supplying energy to the load that produce by the generator.

For stand-alone room lighting systems, energy storage devices are need to store electricity for usage when the wind is absent. Wind energy systems have a fluctuating power output due to the variability of the wind speed with power output varying by the speed. Integrating an appropriate energy storage system in conjunction with a wind generator removes the fluctuations and can maximize the reliability of power to the loads. In addition, both system voltage and frequency can be regulated and controlled [6]. The dominant energy storage for stand-alone wind energy system is using lead acid battery.

Small wind energy conversion systems can offer beneficial alternatives sources of power. This paper investigated the design of a wind energy conversion system. This system consists of a battery storage system that will compatible with other wind system circuit like charge controller. It is designed to maximize wind energy capture through the charge controller that will store in battery storage system and to provide protection to the battery by regulating the current flow.

A. Wind Energy System Configuration

The proposed room lighting system in the room with a Vertical blade, DC generator, charge controller, Lead Acid storage device and loads. It supplies DC loads, around 6VDC that produced by wind DC generator from fan sources in the room. The wind turbine generates a variable dc voltage, which is directly will store in battery storage or directly supply for lighting in the room which can devide decision from charge controller.

The input voltage to the charge controller varies with the wind speed, and charge controller will produce output voltage that is kept constant to the battery. This is important because a variable dc voltage is unsuitable for battery charging as the power provided may be too high, causing damage to the battery. The main challenge is that wind power is variable, that even when wind is at low speeds or at high speeds the dc output voltage should remain constant. [3]. The battery is able to supplement the power provided to the load by the wind turbine when the wind speed is below a threshold value.

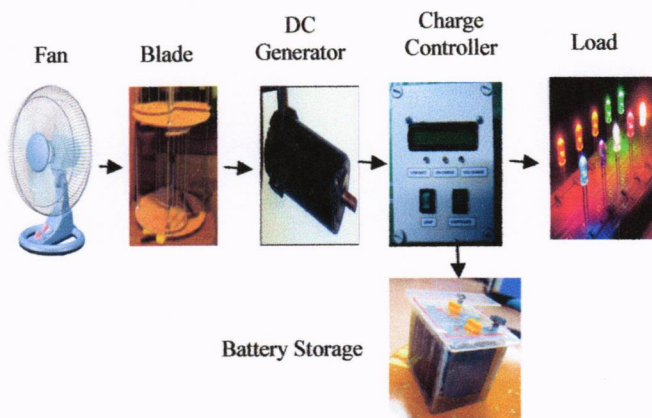

Figure1: Flow diagram of stand-alone wind energy concept

II. METHODOLOGY

For battery charging stand-alone wind turbine, a type of battery storage is required to match as well as function with charging controller.

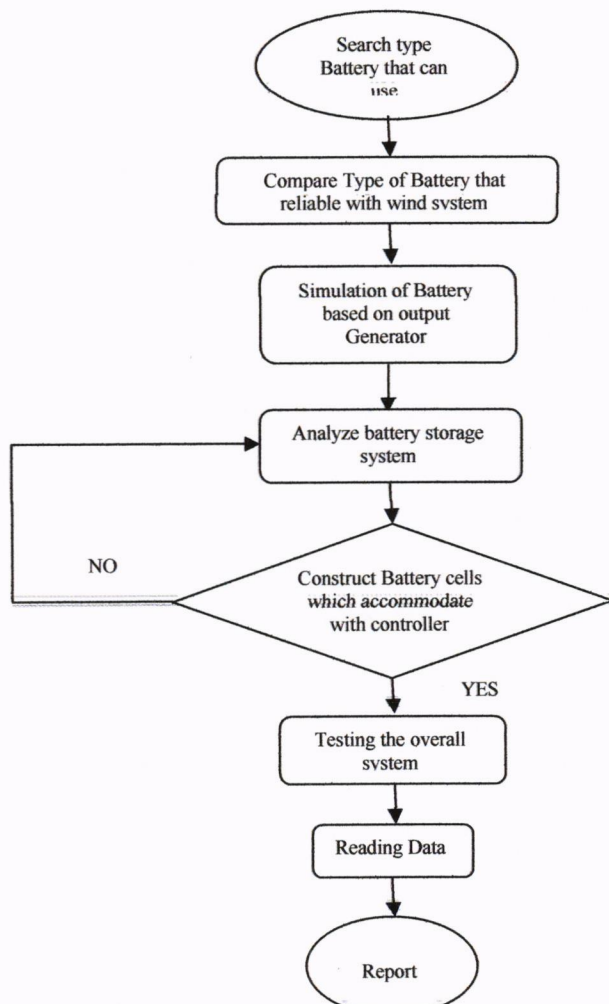

Figure 2: Method Overview

Stand alone room lighting powered by the wind energy is divided into three main parts that consist generation part, controller part and finally storage part. Each part designed with suitable to the condition of home fan. This is important to make sure there are matching to produce high efficiency and optimum power absorptions.

The battery is able to supplement the power provided to the load by the stand-alone wind turbine when the wind speed is below a threshold value. Current flow into and out of the battery is controlled by the charge controller. In this investigation, type battery that will used is Lead Acid Battery (LAB) because this battery suitable from other battery type in term of continuously charging and discharging application for this stand-alone room lighting system and also material cost that consider while design this battery.

This stand-alone system collected wind source from fan that will rotate the vertical blade which is connect directly to the dc generator. This generator will provide DC output voltage directly without use rectifier which will produce voltage that depends on speed (m/s) of fan source.

The controller for this system is used to monitor the battery voltage as an indicator of battery storage. This controller is design using microchip that makes decision to controlled wind sources to battery for charging or directly to load if the voltage supply is higher value from higher battery threshold. This alternative load or dummy load is used to prevent it from over-charging to the battery that will produce gases in battery plate which can make short lifespan for battery cycle.

This research is done by design differences of output voltage lead acid battery that to make sure the battery is suitable for stand-alone room lighting system especially accommodate with controller. The output voltage of the lead acid battery is design with arrangement of battery plate for higher voltage that will accommodate with system which can provide higher battery charge required (Ah).

A. Lead Acid Battery

A lead-acid battery is a secondary (rechargeable) electrochemical device that stores chemical energy and releases it as electrical energy upon demand. When a battery is connected to an external device, such as lighting, chemical energy is converted to electrical energy and direct current flows through the circuit [7].

A 6-volt lead-acid battery is made up of three cells, each cell producing approximately 2.041volts that are connected in series from positive (+) terminal of the first cell to the negative (-) terminal of the second cell and so on. Each cell is made up of an element containing positive plates that connect in parallel between plate in single cell and negative plates, which are also all connected together to increased battery charge capacity. They are individually separated with thin sheets of electrically insulating, porous material or "separators" [8].

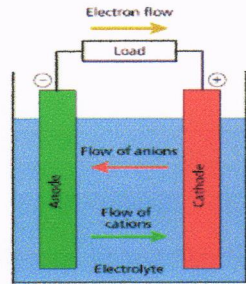

Figure 3: Lead Acid Configuration

Material Used:

- | | |
|-----------------------|----------------------------|
| 1. Acid sulfuric | : H_2SO_4 |
| 2. Lead dioxide metal | : PbO_2 (Positive Plate) |
| 3. Sponge Lead | : Pb (Negative Plate) |

A battery is created by alternating two different metals such as Lead Dioxide (PbO_2), the positive plates, and sponge lead (Pb), the negative plates. Then the plates are immersed in diluted Sulfuric Acid (H_2SO_4), as an electrolyte. The types of metals and the electrolyte used will determine the output of a cell. A typical fully charged lead-acid battery produces approximately 2.041 volts per cell [9].

The chemical action between the metals and the electrolyte (battery acid) creates the electrical energy. Energy flows from the battery as soon as there is an electrical load, for example, a starter motor that completes a circuit between the positive terminal connected to the positive plates and the negative terminal connected to the negative plates [10]. The action of the lead-acid storage battery is determined by chemicals used, State-of-Charge, temperature, and load usage. The electrochemical process for battery discharge process:

I. Battery Discharge

Anode:

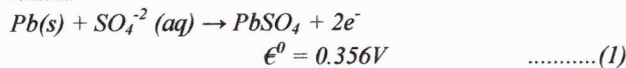

Cathode:

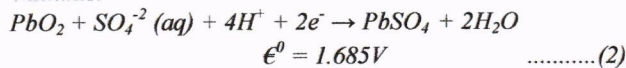

Net:

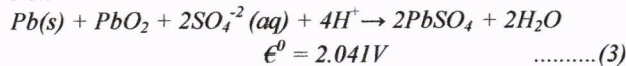

By supplying electrical energy to the battery, this reaction can be reversed and the lead sulfate forced back into solution, and reconstituting the electrodes. This can only happen so many times, however, until the electrodes become so pitted and corroded that cannot be reformed again. The electrochemical process for battery charge process [10]:

2. Battery Charge

Anode:

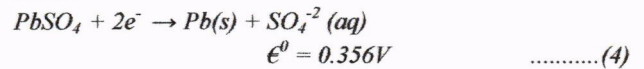

Cathode:

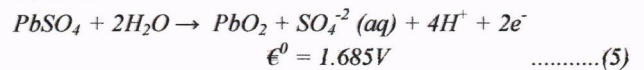

Net:

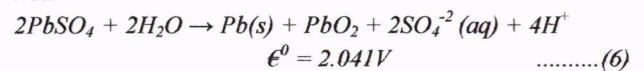

Batteries are ready to work in an instant and can be used in a reasonably wide temperature range. Charging, on the other hand, has limitations and the user should follow recommended guidelines on how and when to charge. Each battery chemistry has its own charging preference. The table below provides basic information for difference battery type.

TABLE I. BATTERY COMPARISON [7]

	Nickel-based (NiCd and NiMH)	Lithium-ion (Li-ion)	Lead-acid
Prepare new battery	Nickel-based batteries come partially charged. Prime new battery by putting on a 14-16h charge.	Li-ion comes partially charged. You can use the battery right away and charge it when needed.	Lead acid comes fully charged. For best result, apply a topping charge to assure full charge.
Discharge method	Fully discharge once every 1-3 months to prevent memory. It is not necessary to deplete the battery before each charge. Over cycling wears down NiMH.	It is better to recharge more often; avoid frequent full discharges. On batteries with a fuel gauge, allow a full discharge once a month to enable reset	It is better to recharge more often; avoid frequent full discharges. Deep cycles wear down the battery. Use a larger battery if full cycles are required.
Charge method	Allow full charge without interruptions. Repeated partial charge can cause heat buildup. (Many chargers terminate charge by heat. A fully charged battery will re-heat, causing overcharge.)	Charging in stages is acceptable. Full charge termination occurs by reading the voltage level and charge current. Charging a full battery is safe and does not cause harm.	Charging in stages is acceptable. Full charge termination occurs by reading the voltage level and charge current. Charging a full battery is safe and does not cause harm.

III. SIMULATION RESULT

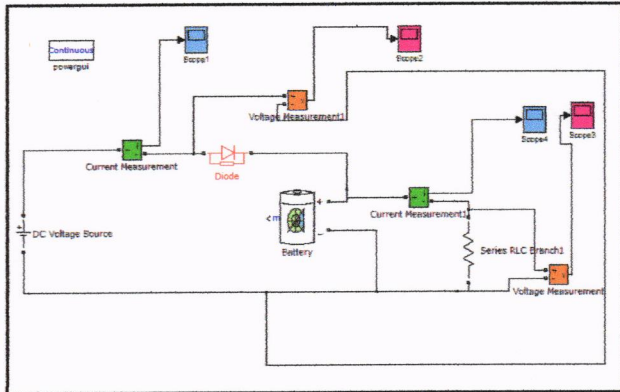

Figure 4: Matlab Simulation

- Scope 1 : Charge Current Flow
- Scope 2 : Input Voltage from Dc Generator
- Scope 3 : Battery Voltage
- Scope 4 : Current Discharged
- Initial Battery : State of Charge (SOC) - 20%

A. At Source Generator 6.20V

1. Battery Charge

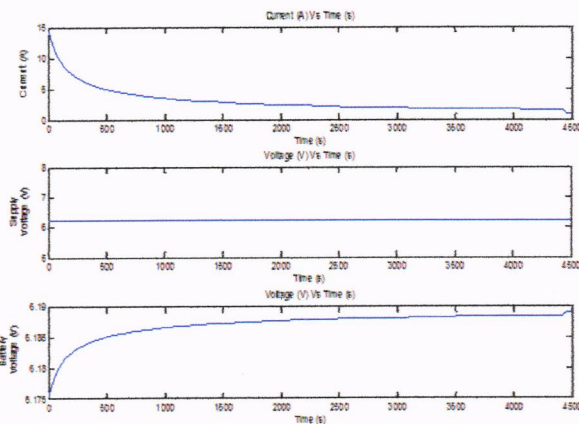

Figure 5: Simulation voltage and current based on 6.20V supply while at charging process

Figure 5 show the simulation of current flow to battery, supply dc generator, and battery voltage. This charging process takes about 4300 second or 1.19 hour to achieve until 6.20V. This simulation is applied dc supply for DC generator output that can produce. Voltage battery increased in term of time because while charging process, current will flow to battery that will increased voltage value but the current flow will decreased and close to 0 after the limit higher limit voltage. In this case, the voltage value can increased until 6.20V because supply just only on 6.20V.

2. Battery Discharge

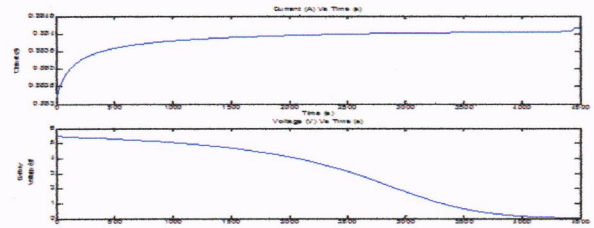

Figure 6: Simulation voltage and current based on 6.20V supply while at discharging process

Figure 6 show the battery voltage and discharge current to the load. The simulation show, battery voltage will decreased while current flow will increased.

B. At Source Generator 6.40V

1. Battery Charge

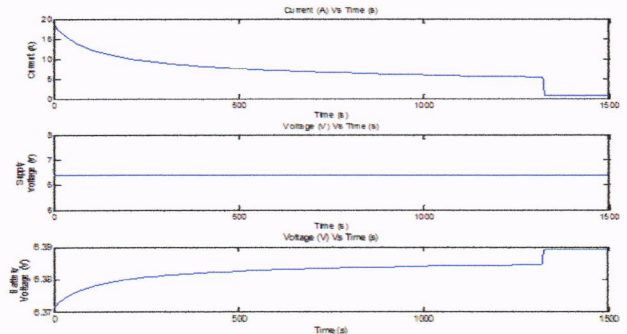

Figure 7: Simulation voltage and current based on 6.40V supply while at charging process

2. Battery Discharge

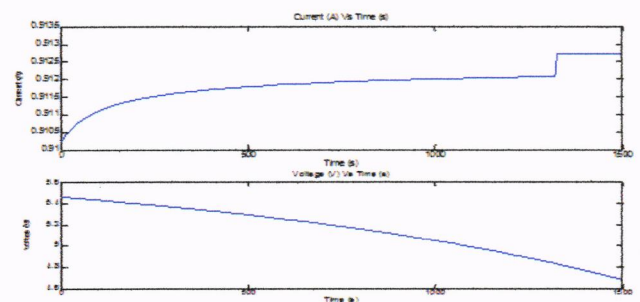

Figure 8: Simulation voltage and current based on 6.40V supply while at discharging process

Figure 7 and 8 show the simulation of current flow to battery, supply dc generator, and battery voltage but with difference supply that around 6.40V. In this case, the charging time is faster than supply 6.20V. The time taken is around 1300 second or 22minutes.

IV. RESULTS AND DISCUSSIONS

The result is collected from the experiment on integration overall system. The experiment does on a difference room size using difference types of stand-alone home fan. The test is carry in the bed room for the a few hours. The data collected will be analyzed to see whether the blade can produce the desired output voltage to charge battery in the room.

A. Experiment on Room 1

Room Size : 12' × 6' × 8'
 Blade : 8 blades (Vertical)
 Position : 0.5 Meter
 Battery type : Rechargeable battery Lead acid
 6V
 Starting Battery : 5.372 V (20%)

This experiment done that fan directly focused through blade. This experiment also uses difference position of fan. To get various output, 2 fan is use to get more output variation. Table below show the output voltage that produce by difference wind speed.

Table II show the output voltage and current of generator that can produce by 8 blades test depend on wind speed. This generator can produce DC voltages that directly connect to battery for charging purpose without additional circuit like rectifier.

TABLE II. STAND ALONE FAN FOR 6 BLADES TEST

Wind Speed (m/s)	Generator Speed (rpm)	Output Generator Voltage (V)	Output Generator Current (A)
0	0.00	0.00	0.00
1	3.78	108.5	3.85
2	4.01	118.5	4.05
3	5.14	167.8	5.16
4	5.20	175.5	5.28
5	6.20	216.0	6.28
6	6.30	210.0	6.40

Table III shows the output voltage and current of generator that can produce by 6 blade test depend on wind speed. This generator can produce DC voltages that directly connect to battery for charging purpose without additional circuit like rectifier.

TABLE III. STAND ALONE FAN FOR 8 BLADES TEST

Wind Speed (m/s)	Generator Speed (rpm)	Output Generator Voltage (V)	Output Generator Current (A)
0	0.00	0.00	0.00
1	3.78	108.5	3.90
2	4.01	118.5	4.10
3	5.14	167.8	5.08
4	5.20	175.5	5.18
5	6.20	216.0	6.20
6	6.30	210.0	6.31

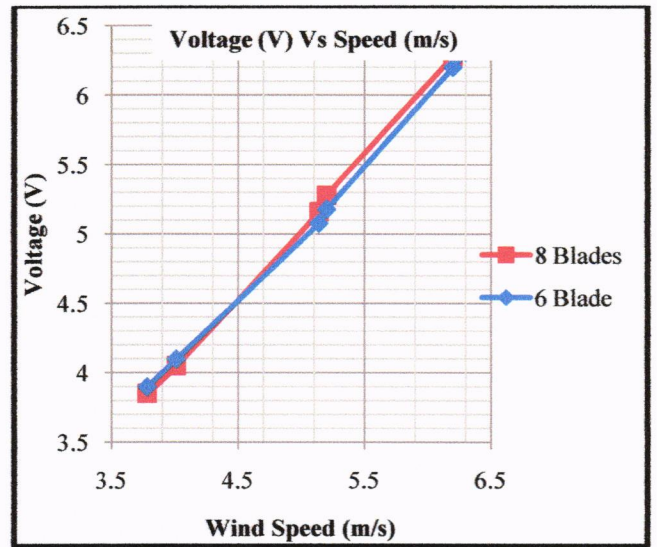

Figure 9: Output generator voltage depends on wind speed

Figure 9 show DC output voltage of generator that produced increased for difference wind speed (m/s) of fan at the same room for difference number of blade. Output voltage increased by increasing wind speed of fan. Output voltage can be higher value if wind speed higher. Output voltage for 6 blades is higher than 8 blades until speed of wind is 4.5 m/s, and the 8 blades produce higher output voltage after 4.5m/s. 6 blades is higher than 8 blade for the at lower wind that it more lighter rather than 8 blade to rotate, but after 4.5 m/s, 8 blades produce more output that weight of this blade will force to rotate more faster.

TABLE IV. CHARGING TIME BASED ON 6.40V

Time in Hour (Hr)	Generator Output Voltage (V)	Battery Voltage(V) With no Load	Battery Current (A) Flow
0.0	6.40	5.37	1.50
0.5	6.40	5.54	1.31
1.0	6.40	5.66	1.13
1.5	6.40	5.81	0.80
2.0	6.40	5.94	0.72
2.5	6.40	6.10	0.65
3.0	6.40	6.24	0.31
3.5	6.40	6.37	0.001
4.0	6.40	6.37	0.001
4.5	6.40	6.37	0.001

Table IV indicate the battery voltage while charging in term of time. This experiment is constructing for higher value of output voltage that can produce by generator that taken from fan test. The value battery starting is at condition 20% state of charge.

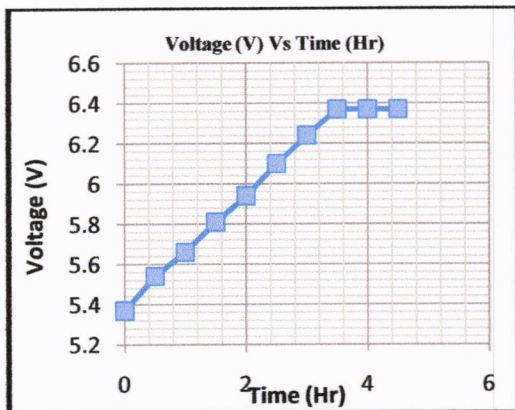

Figure 10: Voltage battery charging time on 6.40V

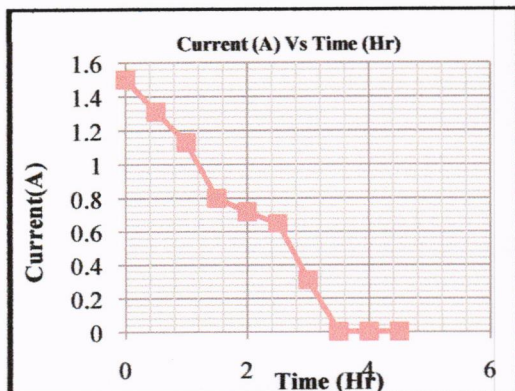

Figure 11: Current battery charging time on 6.40V

Figure 10 and 11 show the experiment result for battery voltage and current flow to battery. From this figure, the time taken for charging this battery is draw until 3.5 hours for this room that take the higher value of generator output voltage that can produce.

Figure 11 show the current that produce by generator to battery is not slightly decreased because voltage constant is set by charge controller. In this case, the output current varies that supplied to battery

B. Experiment on Room 2

Room Size : 20' × 10' × 8'
 Blade : 8 blades (Vertical)
 Position : 0.5 Meter
 Battery type : Rechargeable battery Lead acid 6V
 Starting Battery : 5.372 V (20%)

TABLE V. STAND ALONE FAN FOR 6 BLADES TEST

Wind Speed (m/s)	Generator Speed (rpm)	Output Generator Voltage (V)	Output Generator Current (A)
0	0.00	0.00	0.00
1	3.70	106.0	3.86
2	4.06	114.5	4.12
3	5.05	163.2	5.11
4	5.18	170.5	5.24
5	6.12	189.4	6.15
6	6.25	208.0	6.24

Table V shows the output voltage and current of generator that can produce by 6 blade tests depend on wind speed

TABLE VI. STAND ALONE FAN FOR 8 BLADES TEST

Wind Speed (m/s)	Generator Speed (rpm)	Output Generator Voltage (V)	Output Generator Current (A)
0	0.00	0.00	0.00
1	3.70	106.0	3.81
2	4.06	114.5	4.00
3	5.05	163.2	5.10
4	5.18	170.5	5.21
5	6.12	189.4	6.20
6	6.25	208.0	6.32

Table VI show the output voltage and current of generator that can produce by fan for 8 blade test depend on wind speed. This generator can produce DC voltages that directly connect to battery for charging purpose without additional circuit like rectifier. This output is lower than 1st experiment because the room size affects the wind speed.

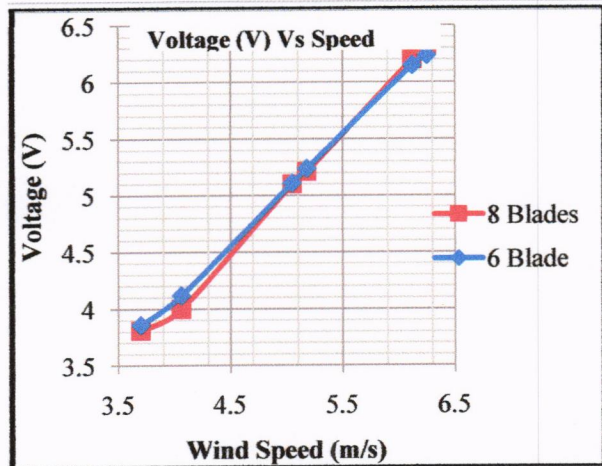

Figure 12: Output generator voltage depends on wind speed

Figure 12 show DC output voltage of generator that produced increased for difference wind speed (m/s) of fan at the same room for difference number of blade. Output voltage increased by increasing wind speed of fan. Output voltage can be higher value if wind speed higher. Output voltage for 6 blades is higher than 8 blades until speed of wind is 5.5m/s, and the 8 blades produce higher output voltage after 5.5m/s. 6 blades is higher than 8 blade for the at lower wind that it more lighter rather than 8 blade to rotate, but after 5.5m/s, 8 blades produce more output that weight of this blade will force to rotate more faster.

TABLE VII. CHARGING TIME BASED ON 6.20V

Time in Hour (Hr)	Generator Output Voltage (V)	Battery Voltage(V) With no Load	Battery Current (A) Flow
0.0	6.20	5.38	1.31
0.5	6.20	5.48	1.26
1.0	6.20	5.58	1.13
1.5	6.20	5.67	0.80
2.0	6.20	5.79	0.72
2.5	6.20	5.88	0.65
3.0	6.20	6.01	0.31
3.5	6.20	6.09	0.11
4.0	6.20	6.19	0.001
4.5	6.20	6.20	0.001
5.0	6.20	6.20	0.001

Table VII indicate the battery voltage while charging in term of time. This experiment is constructing for 2nd higher value of output voltage that can produce. This value is taken because the higher value is closely same with value 6.40V for 1st room which time of charging is closely same. The value battery starting is at condition 20% state of charge.

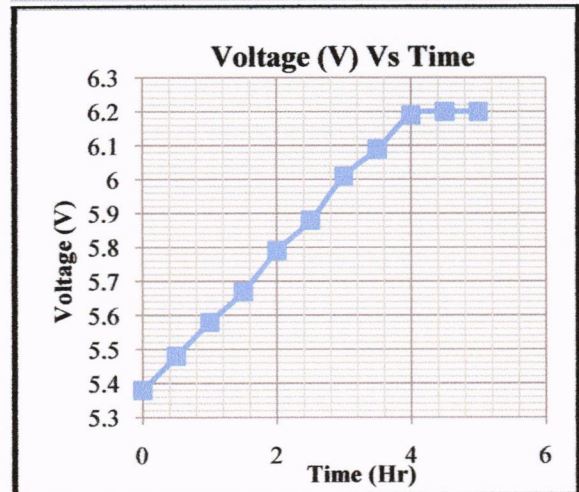

Figure 13: Voltage battery charging time on 6.20V

Figure 13 and 14 show the experiment result for battery voltage and current flow to battery. From this figure, the time taken for charging this battery is up to 4 hours for this room that take the 6.20V of generator output voltage that can produce.

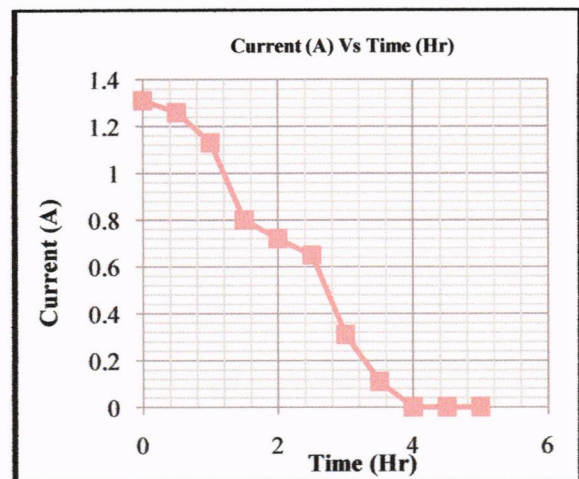

Figure 14: Current battery charging time on 6.20V

Figure 14 show the current that produce by generator to battery is not slightly decreased because voltage constant is set by charge controller. In this case, Wind energy systems have a fluctuation current output due to the variability of the wind speed.

TABLE VIII. COMPARISON SIMULATION AND EXPERIMENT

	Simulation Result		Experiment Result	
Voltage (V)	6.20	6.40	6.20	6.40
Charging Time (Hr)	1.19	0.36	4.0	3.5

From comparison table VIII, the simulation result shows the fast rate of time while charging but in experiment; it takes time more than 1 hour. This case happen maybe the battery is not good enough and losses that occur at charge controller, because charge controller also use energy by this battery. This mean, the discharging process is occurring while generator voltage is supplied to battery.

V. CONCLUSION

In this paper, a stand-alone wind energy conversion system using a 6VDC Lead Acid Battery as an energy storage device to stabilize the output voltage is analyzed. A directional charge/discharge controller is presented that successfully uses the Lead Acid Battery to maintain the load voltage while also regulating the current flow to the Lead Acid Battery to avoid overcharge.

The Lead Acid Battery is suited for renewable energy applications because charging and discharging process will not affect lead acid cycle used rapidly compared than nickel cadmium.

The battery storage system that is work as to storage the energy collected by the generator and supply to the stand-alone room lighting. For stand-alone systems, energy storage device are essential to store electricity for use when the wind is absent. Wind energy systems have a fluctuation power output due to the variability of the wind speed.

The type of battery storage also play a big role in this effectively. This battery storage system also identified to appropriate battery storage system integration with dc generator and charge controller for stand alone room lighting.

ACKNOWLEDGMENT

The gratefully acknowledge to Prof.Ir.Dr.Shah Rizam Binti Mohd Shah Baki and Madam Rahmatul Hidayah Binti Salimin for guidance, support, commitment, and opinion in completing this research. Their contribution is really appreciated and grateful.

REFERENCES

[1] L. Barote, R. Weissbach, R. Teodorescu, C. Marinescu, M. Cirstea, "Stand-Alone Wind System with Vanadium Redox Battery Energy Storage" *Journal of University/Electrical Engineering and Computer Science, Brasov, Romania*.

[2] S. Deve Gowda and S. Raja Pandian, "Simulation of Simple Standalone Wind Energy System" *Proceeding of India International Conference on Power Electronic 2006*.

[3] S. Eren, J.C.Y. Hui, D. To and D. Yazdani, "A High Performance Wind-Electric Battery Charging System", *IEEE, Electrical and Computer Engineering*, pp.2275 – 2277, May 2006.

[4] H.Deguchi, N. Tokuda, T. Kanno, K. Motoi, T. Kumamoto, T. Itoh, S. Ogino, T. Shigematsu, and T. Hara, "Development of a 450kW "Vanadium Redox Flow Battery System" 33rd *Intersociety Engineering on Energy Conversion*, pp. 1074-1079, Aug. 1998.

[5] 'T. Itoh, N. Tokuda, T. Kanno, A. Ikeuchi, K. Kawai, and T. Hara, "Development of Vanadium Redox Flow Battery System" 34th *Intersociety Engineering on Energy Conversion*, pp. 193-198, 1999.

[6] M.Gattrell, J.Park, B.MacDougall, J.Apte, S. McCarthy, and C. W. Wu, 'Study of the Mechanism of the Vanadium 4+/5+ Redox Reaction in Acidic Solutions', *Journal of the Electrochemical Society*, Volume 151, Issue 1, pp.A123-130,2004

[7] Isidor Buchmann,"Batteries in a Portable World", *a handbook on rechargeable batteries for ncle Batteron-engineers*, Cadex electronics Inc.

[8] S. Drouilhet, E. Muljadi, R. Holz and V. Geovogian "Optimizing small wind turbine performance in battery charging applications", in NREL/TP-441-7808. Golden, CO: National Renewable Energy Laboratory, 1995

[9] Bill darden, deep cycle Battery <http://www.battery.council.org/made.html>

[10] James R.Duffey, Batteries and Charging Systems for QRP, *Pacificon 2005, San Ramon, California, October 15, 2005*.