



UNIVERSITI TEKNOLOGI MARA
FACULTY OF INFORMATION MANAGEMENT

INDUSTRIAL TRAINING REPORT:
BAHAGIAN HAL EHWAL AKADEMIK (HEA)
UNIVERSITI TEKNOLOGII MARA (KELANTAN)
BUKIT ILMU, 18500 MACHANG, KELANTAN

SPECIAL PROJECT:
“E-SUPER SYSTEM”

BY
WAN MUHAMMAD SAFUAN ALAUDDIN BIN WAN SUHAIMI
2015834346

IM245 – BACHELOR OF SCIENCE (HONS)
INFORMATION SYSTEM MANAGEMENT
FACULTY OF INFORMATION MANAGEMENT
UNIVERSITI TEKNOLOGI MARA KELANTAN

01 AUGUST 2017 – 31 DECEMBER 2017

INDUSTRIAL TRAINING REPORT:
BAHAGIAN HAL EHWAL AKADEMIK (HEA)
UNIVERSITI TEKNOLOGI MARA (KELANTAN)

SPECIAL PROJECT:
(E-SUPER SYSTEM)

BY
WAN MUHAMMAD SAFUAN ALAUDDIN BIN WAN
SUHAIMI

FACULTY SUPERVISOR
MADAM KHADIJAH BT ABDUL RAHMAN

REPORT SUBMITTED IN FULFILLMENT OF THE
REQUIREMENT FOR THE INDUSTRIAL TRAINING
FACULTY OF INFORMATION MANAGEMENT
UNIVERSITI TEKNOLOGI MARA KELANTAN

01 AUGUST 2017 – 31 DECEMBER 2017

STUDENT PROFILE



NAME : WAN MUHAMMAD SAFUAN ALAUDDIN BIN WAN SUHAIMI

DATE OF BIRTH

ADDRESS

UITM ID

COURSE : BACHELOR OF SCIENCE IN INFORMATION STUDIES
(HONS) INFORMATION SYSTEM MANAGEMENT

INDUSTRIAL TRAINING

DURATION : 01 AUGUST 2017 – 31 DECEMBER 2017

INDUSTRIAL TRAINING

PLACE : BAHAGIAN HAL EHWAL AKADEMIK UITM KELANTAN

DECLARATION

I hereby declare that this is my original work. I have not copied from any other student's work or from other sources. I am also declare that no part of this report has been published or submitted for publication except where due to reference or acknowledgement is made explicitly in text, nor has any part been written for me by another person. I confirm that I have read and understood the UiTM regulations with regards to plagiarism and will be penalized by the university if found guilty.

Signed by

Wan Muhammad Safuan Alauddin Bin Wan Suhaimi

2015834346

Date of submission: January 2018

ABSTRACT

In this report, its provide a comprehensive description about the practical training which is are being carried out at Bahagian Hal Ehwal Akademik (HEA), UiTM Machang Kelantan for 5 month period. There are 4 chapter's content which include introduction to an organization which are UiTM Machang and Bahagian Hal Ehwal Akademik (HEA). Various department which carry a different role and different job scopes, than the activities that are carried out during the practical training and lastly the lesson gained during the time period of training.

Keyword: *Bahagian Hal Ehwal Akademik, practical, job scopes*



ACKNOWLEDGEMENT

First and foremost, I would like to express my thanks to Allah because of His love and strength that He has given me to finish this internship report. I do thank for His blessings to my daily for good health, healthy mind and good ideas.

For this opportunity, I am very delighted to do the industrial training in Bahagian Hal Ehwal Akademik (HEA) department in UITM Kelantan. It is because they allowed for giving me the occasion to undergo my internship for 5 months. Starting from 1st August 2017 until 31th December 2017 in Academic department for providing me with good facility as well as to work in a friendly environment.

I also would like to express my great appreciation and gratitude to my host academic supervisor Puan Khadijah Abdul Rahman and company supervisor, Puan Najibah Bt Mohamed Nazir as well as other staff in this department for their excellence supervision, valuable advice, feedback and tips as well as their kindness in guiding me to improve my experience on how to work in a team.

They allowed me to encroach upon their precious time from the very beginning of this work till the completion. Without their expert guidance, assistance, direction, affectionate encouragement, comments, suggestions, support, critical suggestions and constructive criticism from time to time throughout this internship it could have been rather difficult for me to complete the whole work in an efficient manner.

I would also like to say thank you and show my gratitude for my beloved parents as well as my family for their understanding and supporting throughout my internship program. In addition, special thanks to all interns that I worked with and spend good moments together in brainstorming ideas, sharing experiences, information, time and I feel grateful towards each of them who

endlessly helping me in time of need, show supports and valuable friendship which helps me to keep strong and be independent.

Thank you.



TABLE OF CONTENT

Student Profile	i
Declaration	ii
Abstract	iii
Acknowledgement	iv-v
Table of Content	vi

CONTENTS**CHAPTER 1: INTRODUCTION**

1.1 Introduction About Practical Training

1-3

1.2 History of UiTM Kelantan

4-9

CHAPTER 2: ORGANIZATION INFORMATION

2.1 Introduction Department Structure

10-15

CHAPTER 3: INDUSTRIAL TRAINING ACTIVITIES

3.1 Training Activities

16-27

3.2 Special Project

28-40

CHAPTER 4: CONCLUSION

4.1 Application of knowledge, skills and experience in undertaking the task

41

4.2 Personal thought and opinion

42-45

4.3 Lesson learnt

45-46

4.4 Limitations and Recommendations	47-49
CONCLUSION	50-51
REFERENCES	52
APPENDICES	

LIST OF FIGURE

Figure 1.1: View of UiTM Kelantan Machang Campus	4
Figure 1.2: UiTM Organizational Chart	9
Figure 2.1: Division of Academic Affairs UiTM Kelantan	10
Figure 2.2: Division of Academic Affairs Organizational Chart	11
Figure 2.3: Academic Management Unit Organizational Chart	12
Figure 2.4: Academic Evaluation Unit Organizational Chart	13
Figure 3.1: Help Desk Counter	19
Figure 3.2: Office Work	21
Figure 3.3: Record Management	24
Figure 3.4: Convocation Ceremony	26
Figure 3.5: Setup Meeting Room	27

CHAPTER 1:

INTRODUCTION

1.1 Introduction About Practical Training

The student who undertakes industrial training is responsible mainly to complete the project and tasks assigned by the organization within the stipulated time frame. As we know, internships provide real world experience to those looking to explore or gain relevant knowledge and skills require entering into particular career field. Internship relatively short term in nature with the primary focus on getting some on the job training and taking what's learned in the classroom and applying it to the real world.

The practical training held for five months from 1st August 2017 until 31th December 2017, as one of the requirements for the award of Bachelor of Science Information (Hons) System Management that student should fulfill the industrial training at Division of Academic Affairs organization as a Bahagian Hal Ehwal Akademik (HEA) for 22 weeks. It is intended to provide useful knowledge and to train the students in order to prepare themselves in the real world and working environment. During the practical training session, many principals and theory regarding organizational function are put to into effect. Most students are prepared with a structure towards learning how the organization works in real life so that the subject learned which is IMC 690 Practical Training can be applied. Most the faculties in UiTM provided practical training to the students and expose the students to the valuable experience in conducting a real experience in the industry after this. This training is carried out in Bahagian Hal Ehwal Akademik (HEA) which is one of UiTM branches located in Kelantan.

The training is provided in order to fulfill the requirements of the IM245 program which is Bachelor of Science Information and System Management. In this training, students will be exposed to the office environment, how to handle various functions in managing information are taught and how to handle the student and user that come to the department and so on. Besides that, it also is very useful in preparing the students to be industry ready professional where all the previously learned the theory will put into immediate effect. It provides insights into the intricacies involved in working in various area of the profession as well as inculcate commitment to work, apply knowledge to practical situation, hone technical and soft skills, get acquainted with professional work environment and develop ethical values.

After training had been complete, hope the students are able to implement everything that already learnt in the industry and provide a huge contribution to the related organization

A lot of effort had been contributed by the organization as well as UiTM in order to prepare the students and it hopefully all the practical training students are able to prove that all the theories and knowledge learned are not going to waste. The details of the organizational structure and nature of training session will be explained in the following chapters.

1.1.1 Objective of The Practical Training

There are many objectives of the practical training are described to complete the Faculty of Information management program in the last semester of study, which are:

- To finish the course provided in the faculty of information management.
- To expose with the working environment to student before they work in the future.
- To give working experience to student.
- To learn the real management and technical aspect in the library environment.
- To build the confidence and self-esteem.
- To inculcate the responsible and trust spirit.
- To provide an official report after finish the practical training.



1.2 History of UiTM Kelantan



Figure 1.1: View of UiTM Kelantan Machang Campus

Universiti Teknologi MARA Kelantan Kampus Machang, formerly known as MARA Institute of Technology, 9th branch campus was inaugurated on 01 July 1985 by YAB Tan Sri Dato 'Haji Mohamad bin Yaakob, the Chief Minister of Kelantan at that time.

The establishment of UiTM is the result of close collaboration between UiTM and the Central Government. As a result of this collaboration, the Central Government has allocated 12 acres of land in Kijang Camp which is located about 8 kilometers from Kota Bharu town owned by Kelantan State Scout Council.

The work of renovating some of the old buildings and construction of new buildings was funded by the Central Government at a cost of RM 1.5 million.

The first batch of 185 students were taken for the semester of July - December 1985 to take Diploma courses in Accounting, Diploma in Business Studies, Diploma in Bank Management and Diploma in Secretarial Science. In the early stages, the number of staff was 71 people, 7 lecturers and 64 non-academic staff.

Fixed campus construction was started in 1993. The Central Government has allocated 200.32 hectares of land in Bukit Anjing, Machang to be a permanent campus. The original name of Bukit Anjing has been elevated to Bukit Ilmu in accordance with its function which provides learning opportunities in various disciplines for Bumiputera. It was inspired by the late Dato Nik Abd. Rashid Nik Abd. Majid, former ITM Director then.

The official transfer to Kampus Machang started on 01 January 1996. UiTM Kelantan, formerly known as ITM, was upgraded to Universiti Teknologi MARA or UiTM on 26 August 1999. Now UiTM Kelantan is expanding to meet the need to be the top University in Kelantan in particular.

Now, UiTM Machang has grown into a huge educational institution where it has over more than 5000 students and hundreds of staff. There are 3 faculties in UiTM Machang which includes the faculty of business, computer science and mathematics, and information management Over 19 full-time and part time courses including pre diploma, diploma, and bachelor degree programs were offered each year and some of the students will move from the campus in Machang and the other one in Kota Bharu.

1.2.1 Vision and Mission

There are following the vision and mission of UiTM Machang Kelantan that towards creating a household name in the country.

Vision

UiTM makes a broad-based university scholarship and academic excellence to lead the Bumiputera dynamism in all areas of world-class professionals in order to be born graduates a competitive global and ethical.

Mission

Enhancing knowledge and expertise in all areas of Bumiputera program delivery through professional research and community service involvement based on the values and ethics of professionalism

1.2.2 Quality Policy

- UiTM Kelantan is committed to conducting good quality Diploma and Bachelor programs in order to produce top professional ethical, and global Bumiputera graduates that will always meet customer needs
- UiTM Kelantan will implement a professional management system efficient, effective, and responsible for the planning, implementation of the program as well as continuous improvements to be a world-class university

1.2.3 Quality Objective

- To provide the maximum opportunities for indigenous people to participate in professional-class education in science, industry, technology trade, art and society.
- To provide the program quality and innovative teaching and meet the needs of the market and customers while supporting national development policies.
- To create the humanitarian development program as a means of applying the system of values in society UiTM.
- To ensure the UiTM products not only meet the local people employment market. but also to serve the global stage
- To make the UiTM a winning organization that can ensure the management of human resources finance and property effectively and efficiently to achieve the educational goals UiTM and play a catalytic role in the development of society

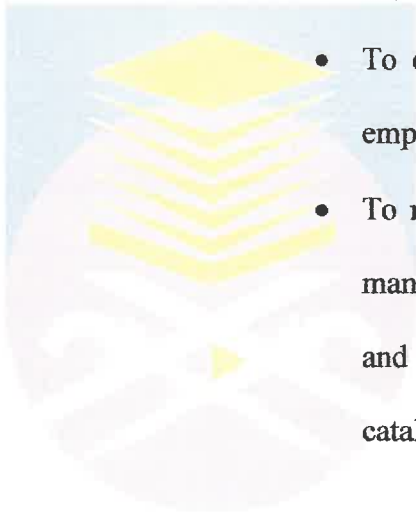

1.2.4 UiTM Machang Customer Charter

- For all customers UiTM :
- Student
- Staff
- Parents
- Industry and
- The stakeholders

The quality service ethics and integrity and also promise that offered by UiTM:

- All basic facilities for learning teaching research and the environment meet the needs MQA KPT and professional bodies.
- All academic programs are approved managed and administered in accordance with the rules and procedures of the University.
- All academic qualification recognized by the government and meets the needs of industry and professional bodies.
- The graduation was given within the prescribed period after fulfilling all conditions.
- All identifiable outstanding achievement and awarded annually.
- All proposals and a formal complaint are taken within one week.
- Always ready to serve the community and,
- Always friendly and professional service.

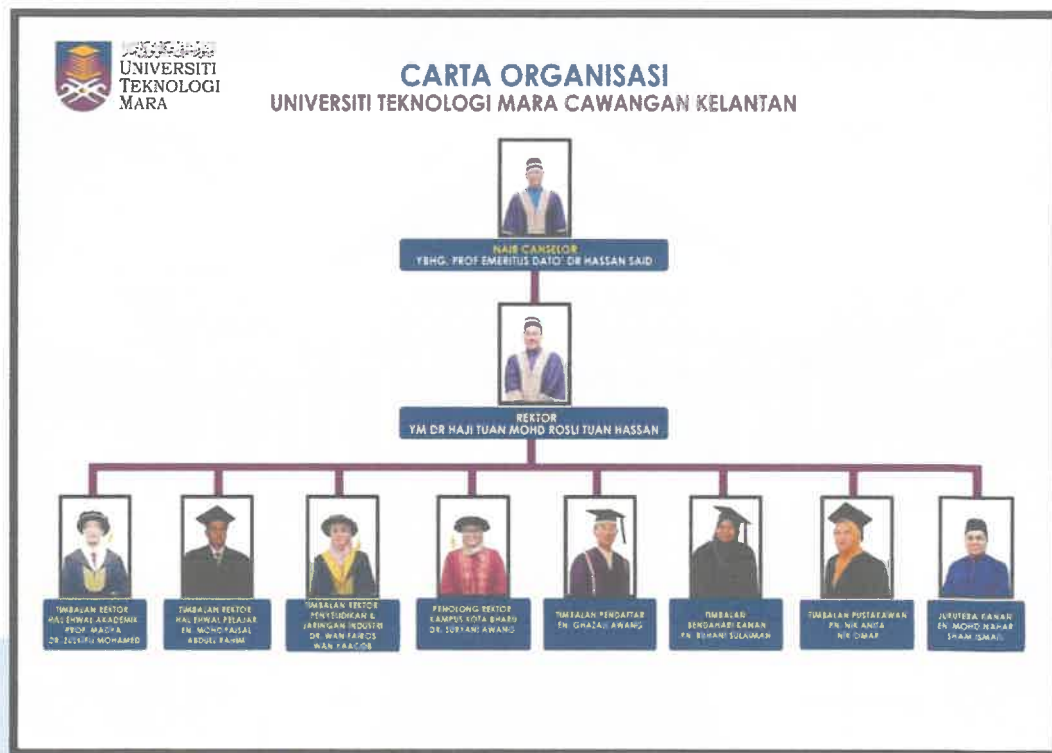

Figure 1.2: UiTM Organizational Chart

CHAPTER 2 :

ORGANIZATION

INFORMATION



Figure 2.1: Division of Academic Affairs UiTM Kelantan

2.1 Introduction Departmental Structure

In this chapter 2, the figure of departmental structure can be seen below in completely with the position of staffs. The functions of every department in the organization also will be explained in this chapter. In, Academic Affairs Division is one of the most important part of the organizational structure of Universiti Teknologi MARA Kelantan Branch. This division consists of two (2) main units namely the Academic Management Unit and the Academic Evaluation Unit. The Academic Affairs Division is responsible for managing matters related to the teaching and learning of academic programs at UiTM Kelantan Branch such as.

- Manage and provide teaching and learning facilities
- Provide and provide support to help facilitate the teaching and learning process
- Managing student records systems, examinations and related academic affairs - information on student studies as well as academic staff affairs

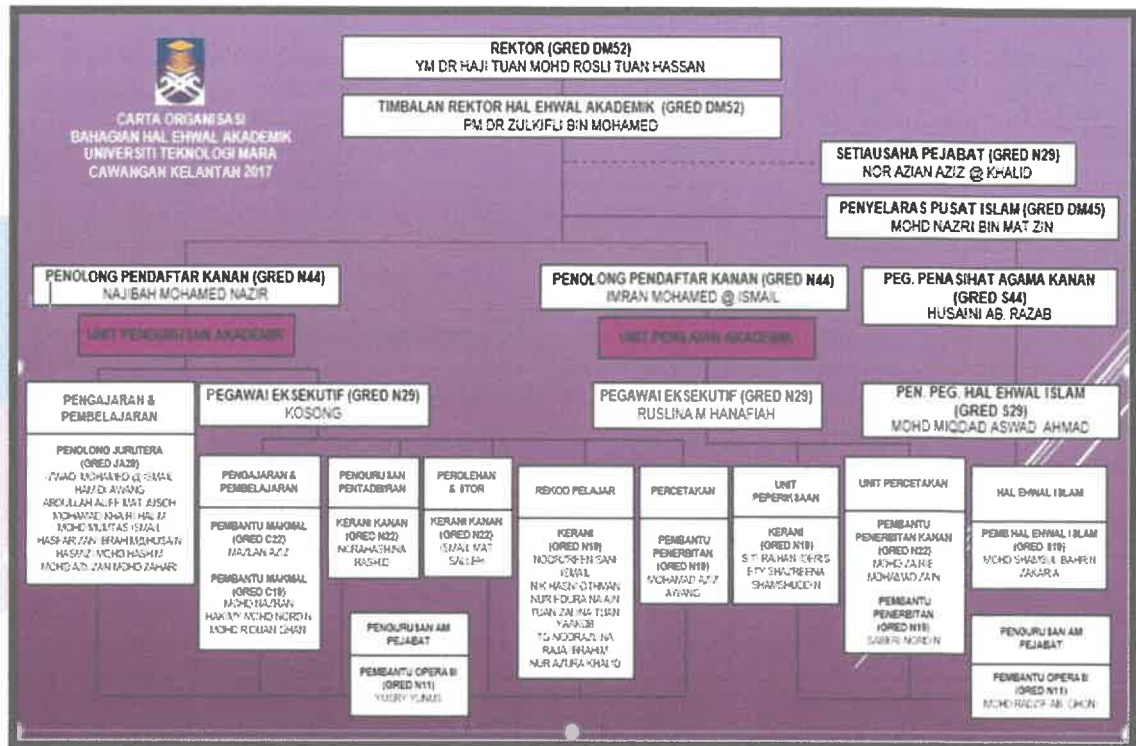

Figure 2.2: Division of Academic Affairs Organizational Chart



Figure 2.3: Academic Management Unit Organizational Chart



Figure 2.4: Academic Evaluation Unit Organizational Chart

Vision

Exercise and strive to spread quality values in managing academic activities towards achieving outstanding academic performance.

Mission

Implement academic programs based on management science to create and develop a more knowledgeable, skilled, innovative, and competent Bumiputera generation, and meet current needs.

Objective

- Provide and coordinate strong learning needs and facilities for students and lecturers.
- Processing and supervising all student academic affairs at UiTM Kelantan.
- Create a harmonious, cheerful and professionally managed environment in implementing effective programs and services based on the latest technologies to maintain the quality of continuous learning.

Customer Charter

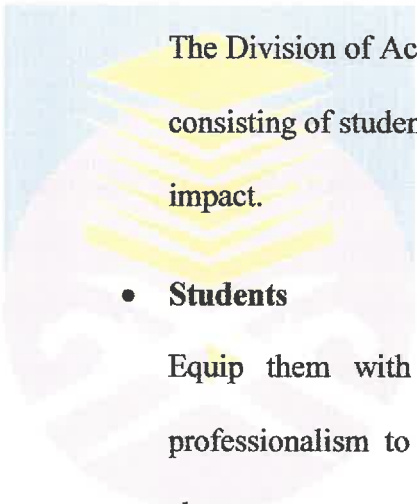

The Division of Academic Affairs (HEA) promises to ensure that our customers consisting of students, lecturers, parents, industry and society have the maximum impact.

- **Students**

Equip them with knowledge, a sense of identity and a high level of professionalism to be able to compete in the outside world and have noble character.

- **Lecturer**

Provide a wide space for lecturers to develop their own potentials especially in the field of scholarship and professionalism

- **Parents**

Provide a good environment and educate students with good character and personality to fulfill the expectations of parents.

- **Industry**

Train students with real-life scenarios, disciplined, highly skilled, professional, prudent and able to become agents of change in organizations and industries.

- **Society**

To provide the best expertise and to develop the socio-economic culture of society.



CHAPTER 3 :

INDUSTRIAL

TRAINING

ACTIVITIES

3.1 Training Activities

During the industrial training, the trainee need to undergo with training activities to complete the internship. The training activities divided into two activities which the first activity is daily tasks provided by the organization and at least one special project either request by the supervisor or recommended by the trainee itself.

Training activities is daily task or activity that the practical student has to do during five (5) months at HEA, which including many scope of work such as administrative work, managing file room, managing event, and many more. During practical training, many program and activities that provided by the organization to practical student such as involved with student convocation. There are a lot of activities and office work can do in HEA. For five months of trainee, many experience that student can get and learn something new. In this office, we cannot expect what we are going to do within course that trainee learn or not.

3.1.2 Daily Activities

- **Meeting**

At the early of the introduction of the Practical student member that consist of 4 member. It is wanted because of the special project that need to be done has been divided by 4 which is E-Super, ATP Amanah Tugas Pensyarah, PA system which is academic advisor system, and Attendance student system. All of the system that will be done by the time given need to be integrated or combine and it will

become one. It is also discussing the special project which is all of the system given.

The meeting also consist of the managing the records that need an arrangement in the HEA archive room. From the past year, the records are not well manage and not well arrange because of the overload records coming year by year. The staff in the HEA department also does not have the time to manage it and as the result, practical student are needed to arrange the records by the year.

The next meeting are focusing on the Convocation program that the practical need to participate, the meeting has been done and the supervisor are given the task on how to manage the convocation. Lastly, the meeting are about the Minggu Destini Siswa (MDS) the practical student are needed to participate in manage the interim student. The meeting consist of on how to control the student and the practical student has given one BIRO. There are a lot of the staff given the meeting or advice because this kind a program are serious matter and it is an UTM program.

- **Help desk customer**

The Hal Ehwal Akademik (HEA) organization mainly consist of student academic problem solving. So, whenever the student have a problem regarding their academic, they can refer to that organization. There will be a time where the staff need a help by locating the practical student at the counter, there are two kind of question mainly ask by student which is through face to face communication and through phone call.

- Face to face communication

The student come to the counter in order to ask the question needed, for example, requesting the mini transcript, certificate of finishing studying, ask the staff about the date of the program.

- Phone call

It is not only the student that call the HEA organization, but, parents and others people that need an information regarding the academic matter.

The student also need to help the staff regarding the student records filling where the practical student need to key in the student name into the system that listing the student name that graduate or does not finish their study. All of the student information need to put in a box that has been provided according the year the semester and the course of the student taken. The list that has been done need to be print out and stick it to the box in order to make it easier to find. If the certain name that need to be review, it can be detected. Plus all of the box are arrange to the year.

Next is, the practical student need to help the staff lifting the A4 paper and A3 paper from the store at the Dewan Professional and move it to the HEA department store. All of the paper needed because of the staff are using it as daily job in a department.



Figure 3.1: Help Desk Counter

- **Office work**

The practical student need to be exposed to any kind of office work. It is because the office work are vital whenever the practical student are responsible handle any kind of office work, for example, photocopying, printing, etc. It is because the practical student are need to be familiar with the surrounding of the office.

There are list of

The most important job that given the practical student an experience is, to operate the problem of personal computer and laptop of the staff. For example, formatting the PC and Laptop, installing the software to the staff, whenever the problem occurred at the personal computer staff, the practical student need to solve it.

Meanwhile, there is a staff from different department that needed a help from the practical staff because the lack of their time. Despite from that, practical student need to help it such as, doing the survey from Google Documents.



Figure 3.2: Office Work

- **Records management**

The records that need to be handle are the one that are no longer used. Thus, the records has increased year by year in HEA department causing they are not systematically organized and managed. As the result, the records are unorganized and the student records are hard to find and it will lead to mishandling the student information. The practical student are responsible in managing those records in order to make it easily to retrieve and it is needed to be sort using systematically order according the year of the recordss created or closed.

The supervisor has make the meeting with the practical student in order to tell the flow on how to make and how to arrange the records by the year. Firstly, the card box need to be flip and it will become the boxes that has been provided by the archives. The boxes are anti-chemical where it is need to be preserve from the others threat. So, it can be stored for a longer time.

Thus, the boxes need to be filled with the student file where they are already graduate and those file are no longer used by the organization. The file that are does not have the boxes need to be filled in the boxes. There are 2 kind of file where it is already have the list of the name, and the file that does not have the list of it. The one with the list provided are just need to stick the list to the boxes. Next, the one that does not have the list of the student name need to be relist into the provided system (automation). It is in form of Microsoft Excel. All the information that need to be listed is the student name, student matrix number, student semester of graduate.

Hence, all of the records in archive room to be moved to the different place as a temporary records keeping. It is because all the records in archive room are does not well managed and the boxes are all in the different places. Meanwhile, the practical student need to arrange the boxes that contain student file need to arrange by the year.

The records that start with 1985 until 2000 are needed to be separate from others records because it is need to be move to the library archive in order to prevent HEA archive lacking their space. The HEA archive are so small that it is need to move some of their records to the library archive. The records that 2001 until latest records need to store in the HEA archive.





Figure 3.3: Records Management

- **Tagging recordss**

The records that are newly arrives or the student that are newly graduate, their records need to be tagged and it is need to be put in boxes that similar to their courses. All of the student name should be key in to the provided Microsoft Excel. After the name of the student has finished key in, the list of it should be print out and stick it to the boxes alongside year, courses, and matrix number.

- **Convocation Ceremony**

In a semester, there will be a Convocation where the graduate student attend it in order to receive their scroll. Preparation of the student convocation should be taken seriously and the practical student need to handle it alongside the staff. The practical student has been given a task where at the early time, they need to check the unreturning convocation robe and it should be report to the staff if the number are decreasing or increasing. Same as the convocation bag, the practical student need to count it. As the convocation day arrives, the practical student need to fill the convocation bag with the goodies, transportation stickers and others stuff that has been supervise by the supervisor. Also, the convocation robe need to be given to the student one by one according the Diploma or Degree level. Whenever the staff need to test the size of the convocation robe, they will ask the practical student to deliver it to them. The staff will take the name of the student and the number of the robe that has been provided in a robe in order to prevent it from missing. After the convocation day, the student need to return the convocation robe to the practical student and staff that are ready up to receive it. The name and the number will be taken from the student as they need to sign the form that say they have return the convocation robe.



Figure 3.4: Convocation Ceremony

- **Setup meeting room**

It is needed when the meeting between the staff is helped at the HEA meeting room there will be a preparation in order to make the meeting run smoothly, for example, the laptop need to be setup, the projector should be check regularly, and others task. While the staff participate in the meeting, the practical need to lift the food from the café to the outside meeting room. All of the furniture need to be enough alongside the participants who attend the meeting.



Figure 3.5: Setup Meeting Room

3.2 Special Project

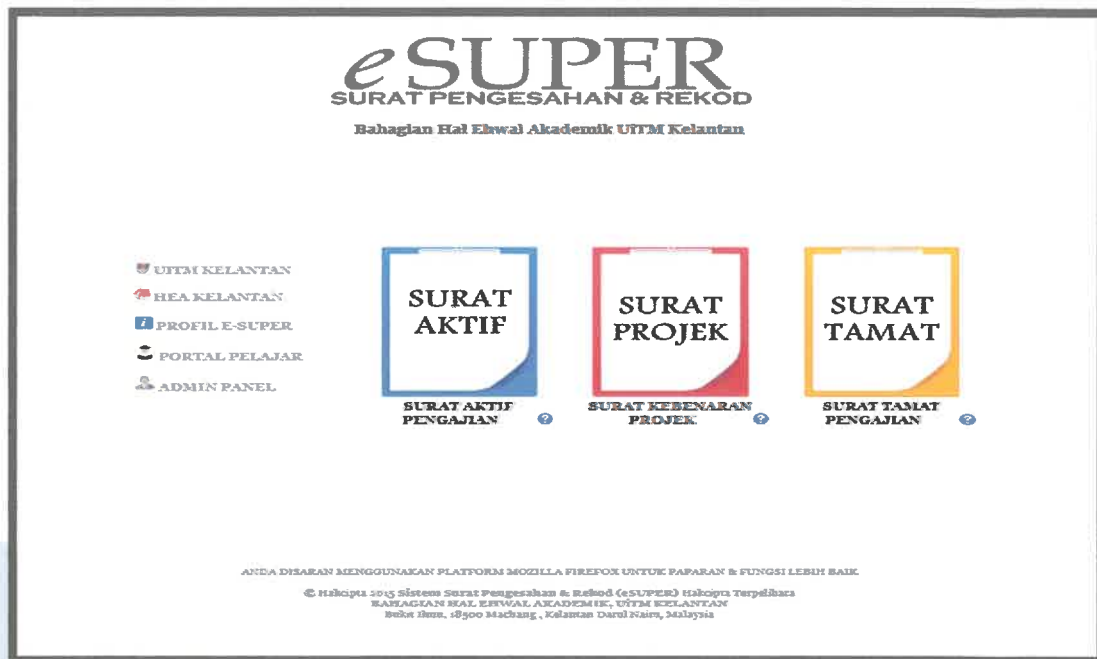

Figure 3.6: Interface e-Super

Student Declaration Letter being one of needs for UiTM student in order to communicate and cooperate with outside organization. e-SUPER is a system that helping the student to generate the declarations letter in ease and quite ways.

There have three (3) types of declaration letter that provide under e-SUPER system.

1. *Surat Pengesahan Pelajar Aktif*
2. *Surat Pengesahan Kertas Kerja/Projek*
3. *Surat Pengesahan Tamat Pengajian*

3.2.1 History of Previous Process

Compare with previous process, the student need to fill the form that provide by the Division of Academic Affairs UiTM Kelantan and it will take about three (3) days to complete the letter.

Universiti Teknologi MARA
Cawangan Kelantan
Bukit Ilmu 18500 Machang
Kelantan Darul Naim

BORANG PENGESAHAN PELAJAR UiTM

BUTIRAN PELAJAR

NAMA PELAJAR :

KOD PROGRAM / BAHAGIAN : /

NO. UiTM :

NO. TELEFON :

BULAN/MULA PENGAJIAN :

BULAN/TAMAT PENGAJIAN :

Tandatangan Pemohon : Tarikh :

* Sila pastikan setiap butir dalam borang **LENGKAP**. Sekiranya ada butir yang **TIDAK LENGKAP**, surat pengesahan **TIDAK AKAN DIPROSES**. (Penerimaan dan proses dalam masa dua (2) hari).

Figure 3.7: Example form *Surat Pelajar Aktif*



 Universiti Teknologi MARA
 Cawangan Kelantan
 Bukit Ilmu, 18500 Machang
 Kelantan Darul Naim

BORANG PENGESAHAN UNTUK KERTAS PROJEK

BIL	NAMA PELAJAR	NO. PELAJAR UiTM
1.		
2.		
3.		
4.		
5.		
6.		

KOD PROGRAM : BAHAGIAN :
 NAMA PROGRAM :
 KOD KURSUS :
 NAMA KURSUS :
 TARIKH MOHON : TARIKH DIPERLUKAN :

Figure 3.8: Example form *Surat Projek*

 Universiti Teknologi MARA
 Cawangan Kelantan
 Bukit Ilmu, 18500 Machang
 Kelantan Darul Naim

BORANG PENGESAHAN PELAJAR TAMAT

BUTIRAN PELAJAR

NAMA PELAJAR :
 NO. KAD PENGENALAN :
 NO. UiTM :
 KOD PROGRAM :
 NO. TELEFON :
 BULAN/MULA PENGAJIAN :
 BULAN/TAMAT PENGAJIAN :

Tandatangan Pemohon : Tarikh :

* Sila pastikan semua butiran dengan LEMKAP. Sekiranya butiran yang dikehendaki TIDAK LEMKAP surat permohonan akan diproses dalam masa dua (2) minggu.

Figure 3.9: Example form *Surat Pengesahan Tamat*

3.2.2 Innovation

Existing systems nowadays, enable student to obtain declaration letter that required as directly at the counter when they are finished to complete the required information.

U-Super system will improve the process which the students can apply the declaration letter as online. As a planning, this system will be uploaded in official website of UiTM Kelantan. This situation can reduce waiting time less than 2 minute for each application (if the information provide by student is accurate and complete).

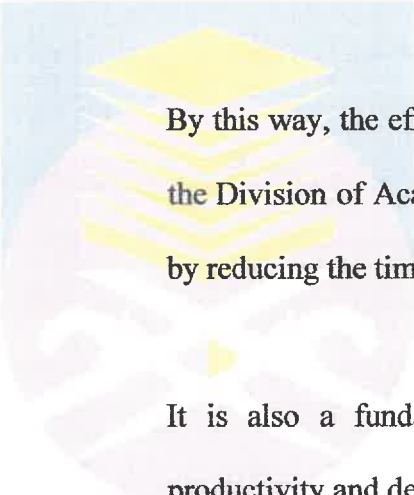

By this way, the efficiency and quality of service to students besides could help the Division of Academic Affairs UiTM Kelantan to improve staff productivity by reducing the time commitment to a task without compromising quality.

It is also a fundamental role in Learn Management which is equivalent productivity and decrease cost.

3.2.3 Objective

- Facilitate the Division of Academic Affairs UiTM Kelantan to produce a letter and keep a records of the student, either individually or collectively.
- Enable affairs issuance of letters and recordss as “web browser” through internet access by student and provide comfort to the student to make the application letter in any place with internet network.

- Provide convenience and facilitate each student to make an application letter in time.

3.2.4 Scope

E-Super system was covered the service that provide by Division of Academic Affairs UiTM Kelantan to their students as a user either in online form or local application. This mean that e-Super system can be access by user as online in official website of UiTM Kelantan, or they may come to the counter (local application) & fill their application with their own.

In e-Super system, there have a few simple forms that user need to fill such as a student's name, their student number, program, course, subject and anything that related with them.

In order to provide this system for user, there have a few of limitation that need to be faced by developer. Manual service which is by using application form and Microsoft Excel already used by Division of Academic Affairs UiTM Kelantan for a long time. So, majority of users become familiar to request their application in previous ways.

In order to introduce this system to them, the trainee need to make a simple interface for this system. With a few of simple instruction, it will help the users easy to understand how the system is function.

3.2.5 Hardware and Software Description

3.2.5.1 Hardware Requirement

- **Laptop (Asus A55v Series)**

Asus A55v Series one of Asus product that categorized as personal notebook by Asus Inc. It consist high quality materials including textured aluminum result in great product strength, a solid feel, and sophisticated aesthetics.

3.2.5.2 Software Requirement

- **JavaScript (JQuery)**

JavaScript was formalized in the ECMA Script language standard and is primarily used in the form of client-side JavaScript, implemented as part of a Web browser in order to give enhanced user interfaces and dynamic websites. This enables programmatic access to environment. JQuery is a cross-browser JavaScript library designed to simplify the client-side scripting of HTML.

- **Warm Server/ Wamp**

Wamp Server is a Windows web development environment. It allows creating web applications with Apache2, PHP and a MySQL database. Alongside, PhpMyAdmin allows managing easily the databases. The function by using this software is as the temporary server for the system which is only for simulation not the actual system.

- **Notepad++**

Notepad++ is a free (as in "free speech" and also as in "free beer") source code editor and Notepad replacement that supports several languages. Running in the MS Windows environment, its use is governed by GPL License.

- **Database (MySQL)**

MySQL is a multi-user SQL database management system (DBMS). MySQL is an open source relational database management system. The SQL part of MySQL stands for "Structured Query Language," which is the most common language used to access databases. Information in a MySQL database is stored in the form of related tables. MySQL databases are typically used for web application development and for embedded web applications, and have become a popular due to its speed and reliability and ease of use

- **PHP**

PHP is general-purpose server-side scripting language originally designed for web development, to produce dynamic web pages. It is one of the first developed server-side scripting languages to be embedded into an HTML source document, rather than calling an external file to process data.

- **Adobe Dreamweaver CS6**

Adobe Dreamweaver CS6 is the industry-leading web development tool, enabling users to efficiently design, develop and maintain standards-based websites and applications. Adobe Dreamweaver is available for both OS X platform and Windows. Recent versions have improved support for Web technologies such as CSS, JavaScript, and various server-side scripting languages and frameworks including ASP, ColdFusion, and PHP.



3.2.6 System Flowchart and Diagrams

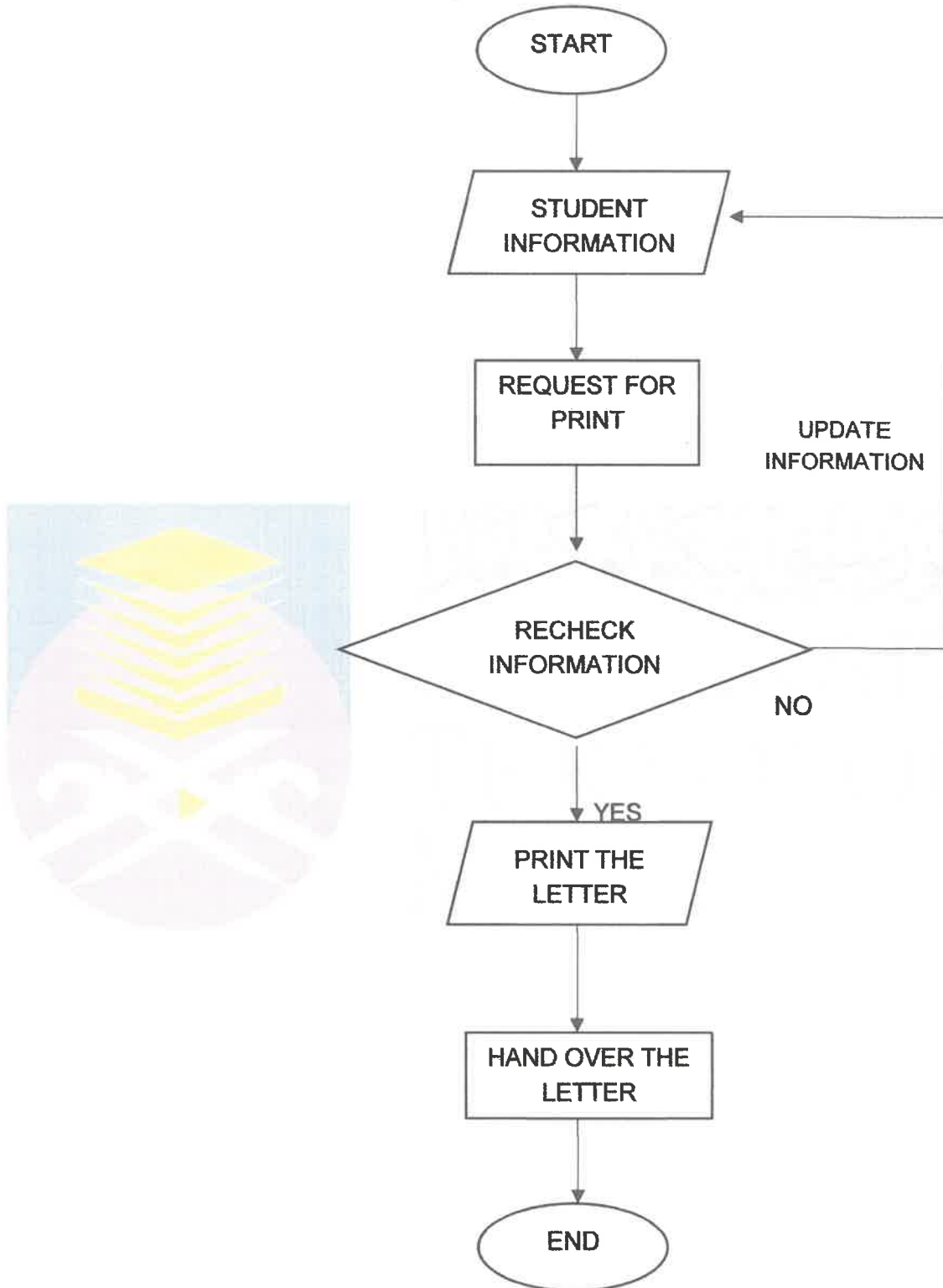

Figure 3.10: e-Super System flowchart

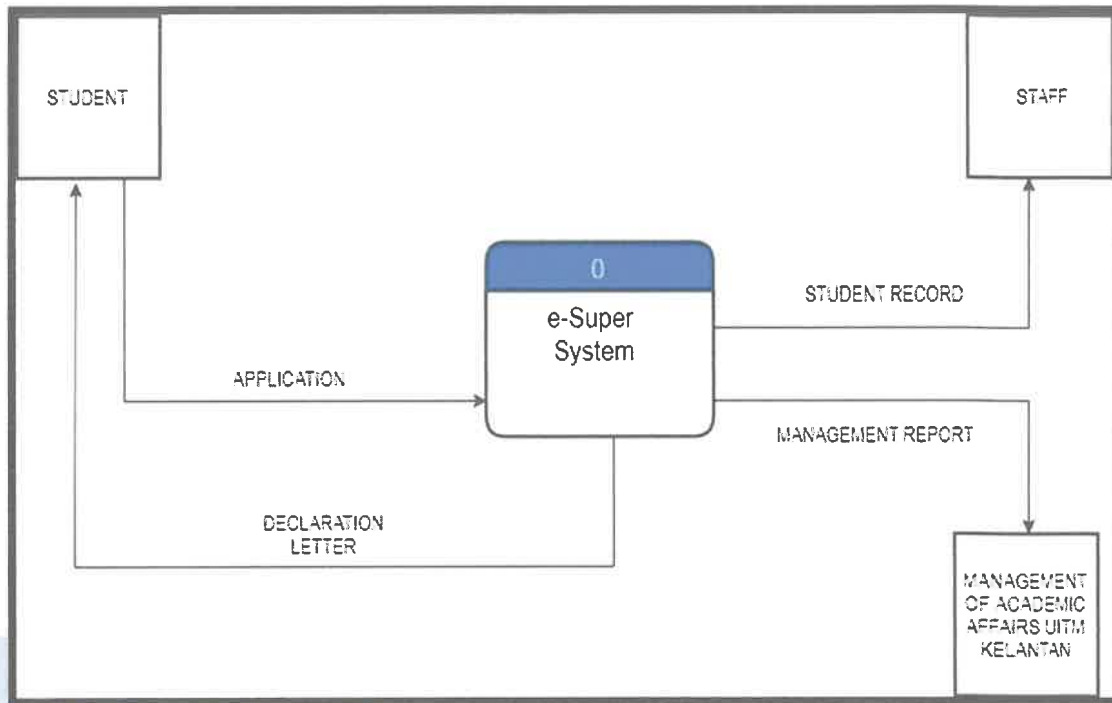

Figure 3.11: Context Data Flow Diagram

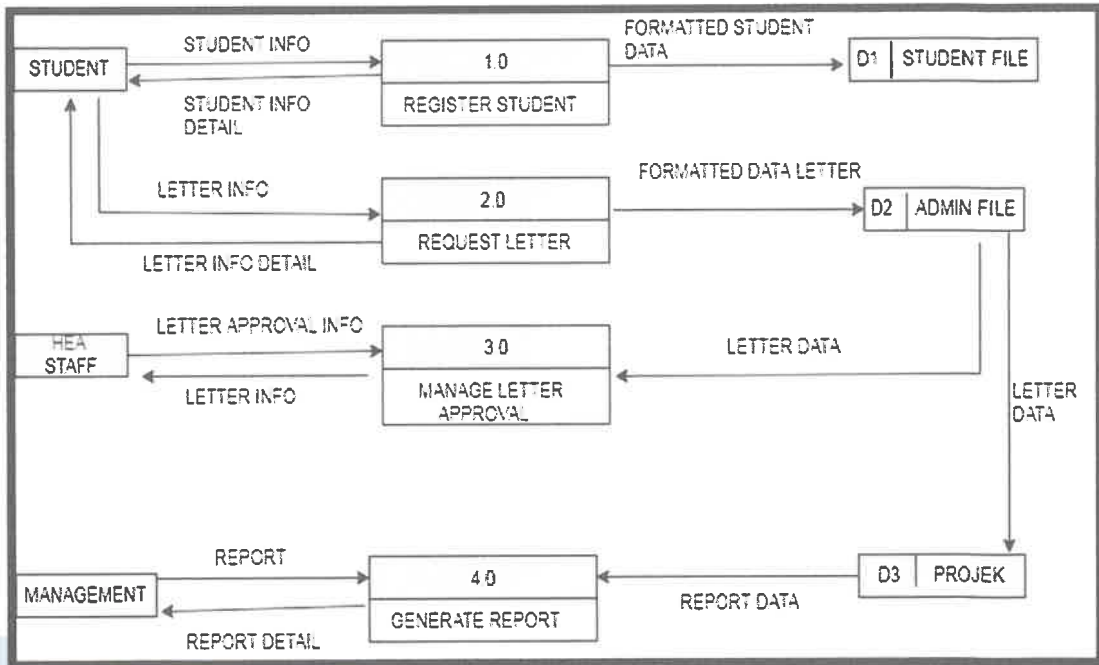

Figure 3.12: Data Flow Diagram

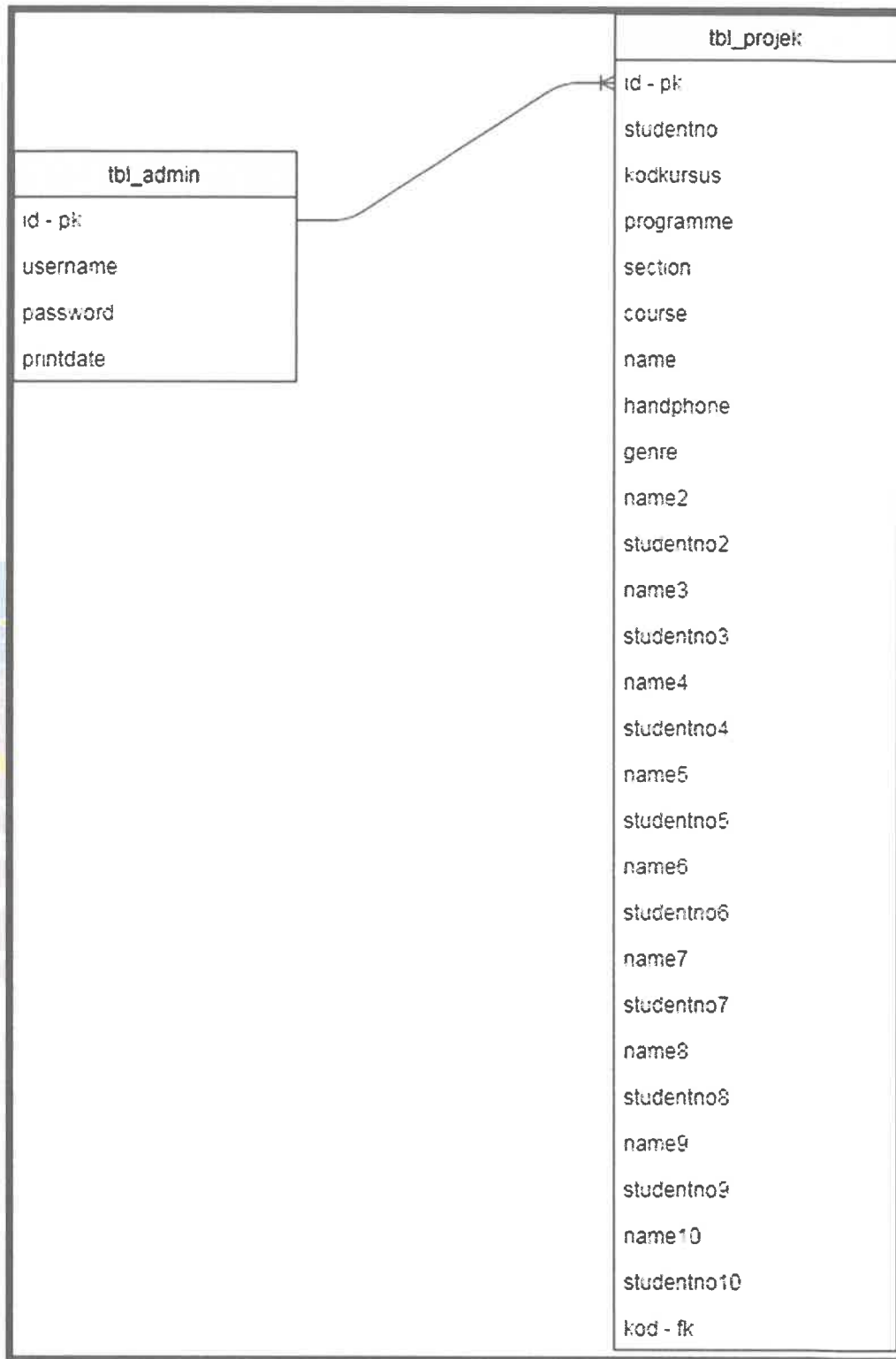

Figure 3.13: Entity Relationship Diagram

3.2.7 Business Rule

- One user can has one and only one active letter
- One active letter can be has by one and only one user
- One user can has one and only one graduate letter
- One graduate letter can be has by one and only one user
- One user can has one project letter
- One user can has many project letter
- Many user can have many project letter
- One project letter can be has by one user
- One project letter can be has by many user
- Many project letter can be have by many user
- One project letter can has one members
- One project letter can have many members
- Many project letter can have many members
- One members can have one project letter
- One members can have many project letter
- Many members can have many project letter

CHAPTER 4 :

INDUSTRIAL

TRAINING

REFLECTION

4.1 Application of Knowledge, Skill and Experience in undertaking the task

(Knowledge gained)

Along five (5) months practical training in Division of Academic Affairs UiTM Kelantan give a lot of new experience to the trainee. From this session, the trainee got to feel the real situation of becoming one of the staff in Division of Academic Affairs UiTM Kelantan. As been said by the lectures, the true nature of work really different from the way that was learned in the classes.

4.1.1 Interpersonal Skill

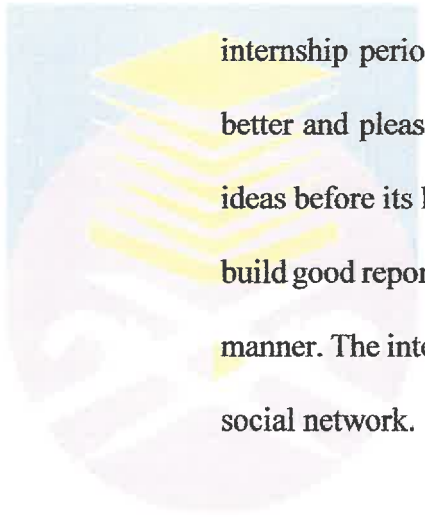

This is most of common and one of the most important skills during trainee internship period. This skill helps a person to interact with others in much better and pleasant manner. It is an art to present one's views, thought, and ideas before its listeners. During trainee internship period, it helped trainee to build good report with the other employees who guided me in the best possible manner. The interaction and dealings with the staff helped trainee broaden her social network.

4.1.2 Build the Relationship

In early, it is really awkward to communicate with the other staffs in the department. However, in order to manage the awkwardness between the trainee and the other staffs, the trainee approach and introduce himself to them. Day by Days, then the trainee recognizes that the senior staffs actually are quite friendly with new out comers. They could accept the new members without being of any compromise. So, it is easier for the trainee to communicate with them.

4.2 Personal Thoughts and Opinion

Based on industrial training session, the trainee managed to learn some new working experience from the real working situation that been showed by the Division of Academic Affairs UiTM Kelantan staffs.

- **Proper Self-Management**

A proper self-management help the trainee in handling the entire practical session.

During the practical session, a good self-management teaches the trainee to handle the entire task perfectly. Different with having complication with job, it also could increase quality and productivity towards your job and projects because good environment will drive us into improvement in work surrounding.

- **Time Management**

Trainee felt that, a lot of lesson learnt that has been acquired during this training and one of them is time management. A good time management is being showed by most of Division of Academic Affairs UiTM Kelantan staffs. Early come to the office but usually become the last person went to home could be great motivation for the trainee. Most of seniors' staff will come to the office at 7.30 am in the morning. This is because, it will help them to prepare early in order to face a lot of requirement on the days.

- **Communications and Soft Skills**

The main lesson learnt that trainee gained while working under Division of Academic Affairs UiTM Kelantan is communications and soft skills. This communication skill is very important in order to help the trainee being very successful person in life. This thought trainee to become quicker thinker to persuade audiences.

Besides, by meet the student everyday will make the trainee try to communicate with them in different ways since being one of Division of Academic Affairs UiTM Kelantan. This is because, in Division of Academic Affairs UiTM Kelantan there are students come here every day with difference of needs and problems. So, in order to handle and solve their problems, we need to communicate with them with suitable approach based on their situation and problem. A good soft skill will help the trainee in communicate approach and the way to solve any problem occur.

- **Work Experience**

Work experience is important for a fresh graduate student. This is because a valuable opportunity for students to gain experience before getting into the real working world. With the knowledge, skills and experience it will give students the opportunity to put what they learned into practice. Besides that, work experience also provides the ideal preparation for a future interview, because the student will have examples and experience to bring in an interview. Once have

some form of practical experience in the workplace, having overcome a difficult interview questions by using existing knowledge.

4.2.2 Opinion

In my opinion, this industry practical is an important thing as it can trained the skills learned by students in their learning in the lecture hall where it can be applied effectively. This is also a branch to build self-confidence students for the real working world that will be encountered in the future. This is because the industry practical has been to provide appropriate disclosure regarding the ins-outs of preparing students for work in the working environment in the future. In addition, it also has allowed me to know the purpose of the lessons in the management of the resources that i have learned.

The training is not only able to increase my self- confidence to face the real working environment, but also has helped me improve the way I communicate with people. Cooperation in the training of staff is very good and this has taught me how the great sense of cooperation. I feel very proud and fortunate to have the opportunity to undergo training in this industry. This is because at present, to get a job in any organization or company we must have the skills that we're in position.

During 5 month industrial training in Division of Academic Affairs as a Bahagian Hal Ehwal Akademik (HEA), I am satisfied with the cooperation attention and guidance that have been provided by the staff no matter what their rank or position. Knowledge and skills acquired during the practical have helped me a lot in improving the performance capability and identify weaknesses that exist in addition to sharpen the theory learned in college.

4.3 Lesson Learnt

Industry training is a good method in which the process can help students in terms of practical methods, as can students acquire some of the activities and tasks performed so students can know every responsibility and role when training period. In addition the industrial training is very effective because it is the students an opportunity to learn the ins and outs of the world of work and conscious of the tasks around is very good for students, especially to open the minds and brains to be more creative and highly knowledgeable and able to deal with the problem and this problem resulting in an actual work situation.

Industrial training as well, not only helped me in a real work situation even helped me improve the way we communicate with the users. Cooperation between the employees benefit me a lot about the sense of teamwork that has been able to build myself when a good job and have a big impact on me when experienced her future. During my practical rainfly, is an alternative to myself to be knowledgeable and experienced in myself and to benefit me in terms of progress in carrying out the work assigned when a real job someday. There are some lessons that I have learned during practical training in which it will explain every skill and knowledge that I've learned

in the Division of Academic Affairs as a Bahagian Hal Ehwal Akademik (HEA). Here are the lessons that I learn in:

- **Human Management**

During practical training there are many experiences that I have faced with the different character of people and also different situation. Sometimes the experienced teach me about the conceptual of adopting good behavior. Brave, confident, honesty, hardworking and many more of good behavior should be adopted in our daily life especially when we working with the other peoples.

During practical training if I could not do the work, I learn to ask someone or staff to help me to do the works. I also learn to do a work in a group because it can save the energy and time management.

- **Customer Service Department**

The customer service department is the department that gives a lot of skills and also provides many related skills towards effective management. This is because the customer service department managing all the aspects related to the academic user and also parent. The skills learned also had given an insight towards the academic staff main service of severing their user effectively and efficiently where involvement in this particular service had given valuable experience in developing good academic staff competencies.

4.4 Limitation And Recommendation

4.4.1 Limitation

- **Side tasks**

The trainee not only got the tasks based on the system management and development. The trainee was asked to assist the clerks at the front desk of Division of Academic Affairs UiTM Kelantan by facing the student's needs every day.

It may cause misunderstanding between the trainee and students about every information that both of them tried to inform. This is because, the trainee was not given enough information in order to handle the front desk while the clerks were out on the time. Besides, it also may disturb early plan by the trainee which is want to focus on system development on the day.

- **Allowances**

As training in UiTM, there have no allowances that provided for any trainee along five (5) months. That situation quite difficult for trainee to living in such expensive cost living. The HEA should consider as trainee should also pay for their rent house that might cost RM150 per month per head. Additionally, the loan from Perbadanan Tabung Pengajian Pendidikan (PTPTN) was ended as there have problem in early agreement. The trainee needs to look for other alternative in other to gather extra money as they don't have any job to be work.

- **Lack of using technology**

The staff in HEA also still lacking in using the technology that need practiced to enhance their skills and knowledge's.

- **Lack of IT Staff**

Besides, during internship, the trainee had been hard the time to communicate with the staff in consultation about system development. The trainee also can't get enough information to complete their task regarding of the lack of IT staff.

- **Lack of space**

The file room has many of documents that need to dispose follow the date. The records or documents in file room at HEA department are not organized well and not follow the records keeping procedures which are current records, semi current recordss and non-current recordss. The documents in HEA mostly not rearrange in the file follow the order such the file administration, student file and more.

4.4.2 Recommendations

- **Side tasks**

Assisting front desk of Division of Academic Affairs UiTM Kelantan may give an opportunity to the trainee in order to discover broader of their job scope so that they would gain more valuable information and experience to be used for their work. But first, Division of Academic Affairs UiTM Kelantan should provide

enough information to the trainee in order to improve the knowledge while cooperate with the clerks and students in front desk.

- **Allowances**

Division of Academic Affairs UiTM Kelantan should consider by giving the allowances to the trainee. This is because of the high cost living with there is no other space for student to make part time work as they must attending very packed training that has been provide to them. So that, the organizations should revise back this matter as to contented the trainee feeling and does not feel worry about the money needed to survive. The organizations also should reflect back by given allowances to trainee for overall duration of their internship.

- **Using technology**

The department need hire the expertise that has more experiences and skills to handle the information technology activities in the HEA

- **Lack of Space**

To make sure all the records students can be save in the academic affairs, I recommend that the academic affairs need to change their arrangement of the file room student.

Conclusion

Overall, the industry training undertaken by students in their final semester is very especially for me. With industry training, it is a platform for me to get to know the real scope of work and wider. In addition, the knowledge acquired during studies at UiTM fully applied in the world of work. The difference in the current study in UiTM and practical training is widely divergent, especially how to communicate with the outside.

A more mature style of communication is something that I get to improve my communication skills. Therefore, this training was very good and should continue to produce graduates better quality in line with the government's intention to create dynamic professionals. During the industrial training in the Bahagian Hal Ehwal Akademik (HEA) UiTM Kampus Machang, a lot of knowledge and new experiences I had when I do work in the office. This knowledge and experience is useful to develop themselves and help to facilitate future.

I also have a lot exposed to various activities and tasks in this department are indirectly i also know every responsibility and role of each employee in the department. Exposure to the real working environment is good for the student especially to open their minds to be more creative and knowledgeable. Students can also identify and address the problems that often arise in a real work situation.

Even the many challenges that have been encountered by each student during the training varies from one industry to another, but what is important is that one should be more positive in the face of every situation so that the experience gained can be used in the future. Lastly, I express all my gratitude to all the Bahagian Hal Ehwal Akademik (HEA) staffs, from all level of the management for their support, cooperation, guidance and advice in order to help me finishing my practical training successfully. I hoped that in the future the valuable

knowledge gained in Bahagian Hal Ehwal Akademik (HEA) will be able to provide a steady and good development in continuing to serve the UiTM community with pride.



References

(2018). *Diagram.IO*. Retrieved from: <https://www.draw.io/>

Puan Najibah Mohd Nazir. (August 1, 2017). Personal interview

Universiti Teknologi MARA. (2017). *Sejarah Penubuhan*. Retrieved from <http://www.kelantan.uitm.edu.my>

Universiti Teknologi MARA. (2017). *Bahagian Hal Ehwal Akademik*. Retrieved from <http://www.kelantan.uitm.edu.my>

