

# Read-Out Interfacing Circuit for ISFET Ionic Concentration Measurement

Turki Abdulmajid Abdo Al-Qutami  
Faculty of Electrical Engineering  
Universit Teknologi Mara  
Shah Alam , Selangor  
Turki.abdulmajid@gmail.com

**Abstract**—This paper is focused on designing a read-out interfacing circuit (ROIC) which has the ability to measure the ionic concentrations by interfacing it with an electrochemical sensor called ISFET the ion-sensitive field-effect transistor. ISFET is fabricated to detect specific ionic concentrations and for this case the ISFET used was the one to measure the PH level in the solution. The ISFET is tested under different conditions such as temperature, biasing voltage and different values of components and how these readings are different between simulation and actual hardware. The ROIC is connected to a microcontroller based-system that measures the output voltage from it and keeps a record of the data. The softwares used were LTspice for simulation, Proteus for PCB design and Arduino microcontroller. The ROIC designed to measure the ionic concentration was constant voltage constant current (CVCC). The IROC was tested under different parameters value of the circuit. Some parameters had an effect of increasing or decreasing on the output voltage from ROIC. The ISFET sensor itself had been investigated under different conditions. It was observed that ISFET is affected by temperature and its fabrication characterization.

**Key words**—ISFET, ROIC, Arduino micro-controller, CVCC, Ionic concentration.

## I. INTRODUCTION

The developments in every field are reaching far dimensions and thus requiring high sensitivity devices. The ion-sensitive field-effect transistor (ISFET) is an electrochemical sensor that has a high sensitivity for the ionic concentrations. It can detect the ionic concentration and the changes occurred by producing an electrical response according to it[1]. The electrical response is the changes of the threshold voltage ( $V_{th}$ ) of the ISFET sensor. ISFET structure is based on Metal-Oxide-Semiconductor (MOSFET). The sensitivity to ions is derived by eliminating the metal gate contact of the MOSFET and exposing the gate insulator to an electrolyte solution [2][3]. The contact to the electrolyte gate is provided by a reference electrode Fig.1 Therefore the electrode is the gate voltage connected to ISFET through the electrolyte solution.

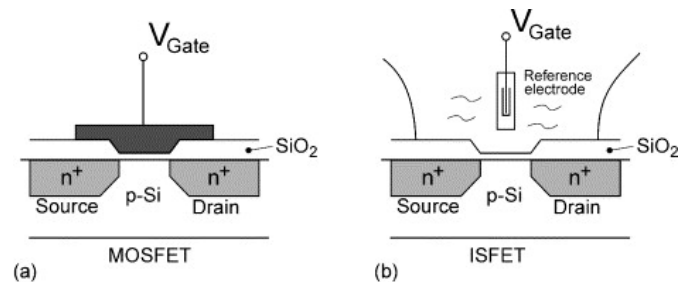

Fig.1. MOSFET and ISFET cross-section structure

The ISFET sensing principle is based on the charge absorption at the ion-solid interface between the sensing layer (membrane) and the electrolyte Fig.2 [4]. The membrane of ISFET can be fabricated to respond only to one species of ionic concentration. The ISFET used in this experiment is ISFET PH sensor.

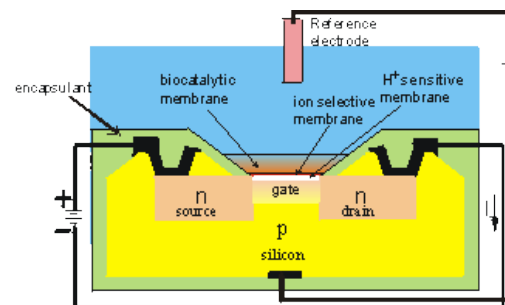

Figure.2. ISFET cross-section structure with H<sup>+</sup> selective membrane

However, in order to make ISFET works, it needs a biasing voltage [6]. By connecting the ISFET to a direct power supply, we will fail to measure the exact ionic concentration even though the IV characteristics can be obtained. The reason is when  $V_{th}$  of ISFET changes due to ionic concentrations, it will affect other parameters to change and make it difficult to monitor only  $V_{th}$ [7]. The best way to measure ionic concentration is to connect the ISFET to another circuit that provides a bias voltage to it and at the same time interprets the electrical response from ISFET only due  $V_{th}$  changes and gives an output voltage that can be measured. ISFET with chemical sensing will help the researches in many fields especially chemical, biomedical and environmental research. Its advantages of high sensitivity and portability is opening the

door solving many challenges. Therefore, the objective here is to build hardware for the read-out interfacing circuit (ROIC) with ISFET that can only read the  $V_{th}$  or the electrical response from ISFET and deliver it to the Arduino voltmeter circuit to be measured and recorded. In addition to that, investigate the behavior of ISFET under different conditions to show how ISFET function differs.

## II. METHODOLOGY

There are two main designs in this project. First is ROIC and second is the Arduino micro-controller based system. The block diagram of whole work is shown in Fig.3.

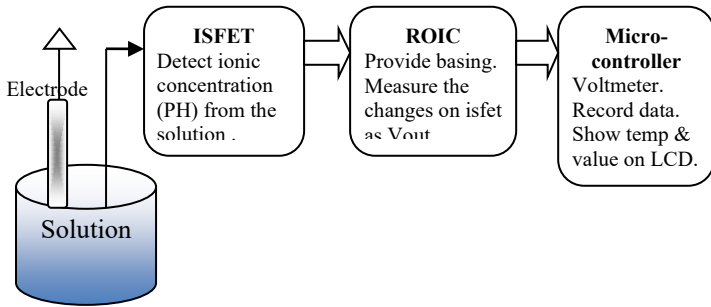

Fig.3. Block diagram of the project

The ISFET used is the research ISFET sensor that can measure PH level. The membrane is fabricated in away to detect +H. The ISFET as in Fig.4 has three pin which are used to connect ISFET to the ROIC. The Pins are bulk voltage (VB), source voltage (VS) and drain voltage (VD).

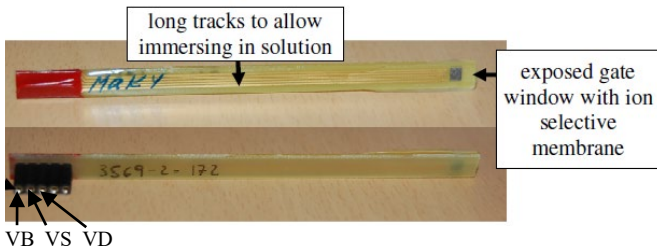

Fig.4. ISFET actual sensor

There are varieties of ROICs that are designed to satisfy the requirements of ISFET. Each circuit has different characteristics in terms of sensitivity, power dissipation and temperature effect. What is more important is the circuit with more sensitivity and the circuit that is proved to have better sensitivity than others is the current-voltage current-source (CVCC) circuit. CVCC is built with two op-amp and two current sources and one variable resistor. The schematic design is show in Fig.5 with the components values. The three terminals VD, VB and VS are the connections to the ISFET sensor. The Current source is set to 100uA by connecting it to an external resistor. The resistor will act as a current set and different resistor will give different current. To get a 100uA, the resistor has to be set to 680ohm.

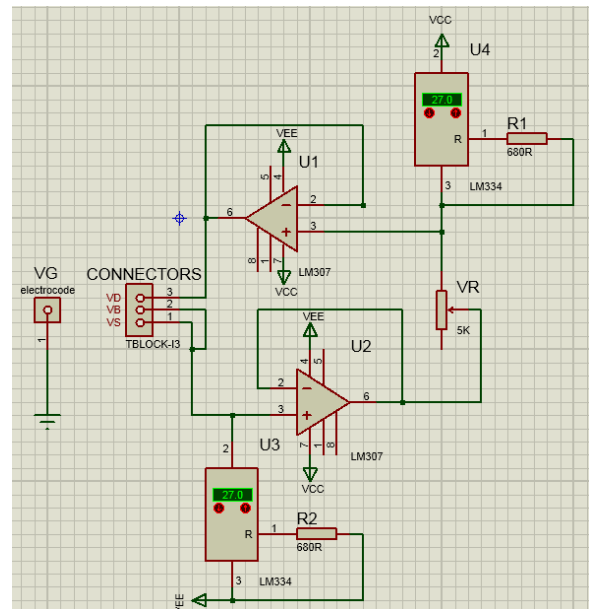

Fig.5. ROIC schematic with the connection to ISFET and electrode

The operation of CVCC circuit relies on two principals of keeping a constant voltage value that is  $V_{ds}$ , the voltage differences between the two terminals of ISFET  $V_D$  and  $V_S$ , and a constant current value that flows in the circuit. Based on these two principals, the circuit can monitor the changes of ionic activity through ISFET without interfering it with other values in the circuit. The operation flow starts by immersing the ISFET into a solution. The ionic concentration activity changes the  $V_{th}$  of the sensor and thus changing the voltage value at terminal  $V_S$ . The current source connected to the same terminal will draw any value from the power source while keeping a constant current value. In addition, the op-amp at the same terminal will deliver the new  $V_S$  to the output since it is designed as voltage follower. The voltage at the output is equal to  $V_S$  and it represents the ionic concentrations. However, the circuit function doesn't stop here and other components play a big major in controlling the circuit as well. The resistor at  $V_{out}$  node has a value of 5K and the current source is constant at 100uA due to current source. Therefore the voltage dropped at the resistor is always 0.5V. The resistor determines what the constant voltage is in the circuit and that is  $V_{ds}$ . The reason is the voltage at node A is found by:

$$V_a = V_{out} + V_r \quad (1)$$

The op-amp at nodeA will deliver the voltage to its output at  $V_D$  terminal. Now, the voltage at  $V_D$  is  $V_{out} + V_r$  which is equivalent to  $V_s + V_r$ . Therefore, the voltage dropped between  $V_D$  and  $V_S$  terminal is  $V_r$  and that gives a constant  $V_{ds}$  controlled by the resistor value.

The Micro-controller system used is based on Arduino Atmega 2256. Microcontroller can only do one function at a time but in micro seconds. The Arduino is designed in this project to perform several functions. First is to work as a voltmeter to measure the voltage output ( $V_{out}$ ) from ROIC.

However, since the analog to digital (ADC) in Arduino is unipolar, its voltages input range from 0 to 5V. It is incompatible with ROIC since the Vout sometime is in negative voltage. Solving this problem is with an external circuit to act as a converter from bipolar to unipolar output. The circuit is a summing amplifier as shown in fig.6.

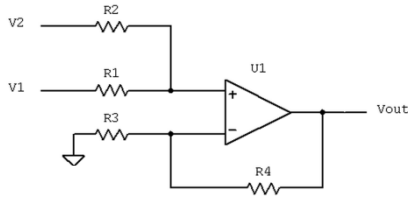

Fig.6. Summing Amplifier to convert the bipolar input to unipolar output.

The value of resistors was chosen based on the requirements of the design. The requirement determined in this project was that the input voltage swings from -5V to +5V and the output value swings from 0V to 5V. As known, the general equation of any linear circuit is :

$$V_{out} = V_{in} * Gain + V_{offset} \tag{2}$$

Vin is the voltage input from the ROIC so there are two unknown values Gain and Voffset. Since the output swing is half the input then the Gain is 0.5V. However, the output now swings from -2.5V to 2.5V so the Voffset has to be 2.5V. The transfer function of summing amplifier is:

$$V_o = \left( V_1 \frac{R_2}{R_1 + R_2} + V_2 \frac{R_1}{R_1 + R_2} \right) \left( 1 + \frac{R_4}{R_3} \right) \tag{3}$$

Equation 3 can be rewritten as:

$$V_{out} = V_{in} * 1/2 + 5 * 1/2 \tag{4}$$

From eq4 and 5, we assumed that V1 = Vin and V2 = 5. By that it means the value of R4 is zero and R3 is infinity. In other way, R4 is a short circuit and R3 is an open circuit. Assuming again that R1 = R2 then the ratio of R2/ (R1+R2) and the ratio of R1/ (R1+R2) is equal to 1/2. Any practical value of the resistors can be chosen and in this project 100kohm was chosen. The summing amplifier after modifications is shown in Fig. 7.

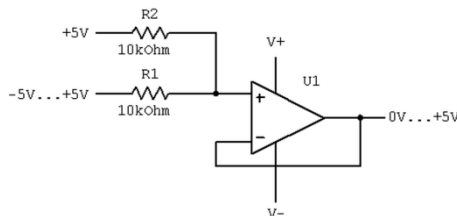

Fig.7. Summing amplifier with resistor values based on the design requirement.

The output from the summing amplifier ranges from 0V to 5V and can be connected to Arduino. It will be measured through one of the analog pins of Arduino. With some

equations and coding, the output voltage from the ROIC can be measured and thus obtaining the ionic concentrations.

Arduino second function is to keep a record of the data obtained through SD module. SD module is connected to Arduino through its pins. However, SD module can only save the data without the real time. Therefore, another board called real time clock (RTC) has to be connected to provide time and date of the taken data.

Last function of Arduino is the complementaries. Temperature sensor is connected to Arduino to keep observing the temperature since the ionic concentrations change due to temp. Liquid crystal display (LCD) is connected to Arduino to display the output voltage that is due to ionic concentration, the temperature, time and date. Last, there are few buttons connected to Arduino. The importance of the buttons is to save the voltage reference (Vref) in the EPROM of the Arduino, change the LCD output and reset. Vref is the voltage reading from another solution to be used as a reference voltage to get a better result of the desired reading as shown here:

$$V_{out} = V_{in} - V_{ref} \tag{5}$$

Where Vin is the output voltage from the ROIC that is measured by the Arduino voltmeter.

### III. RESULT AND DISCUSSION

There are two results obtained from CVCC ROIC. The reading from the schematic design and the reading from the hardware design. The schematic design shown in Fig.9 was drawn by LTspice software. However, there is not an ISFET device to be simulated but it was replaced with an NOMS device since they have the same basic structure.

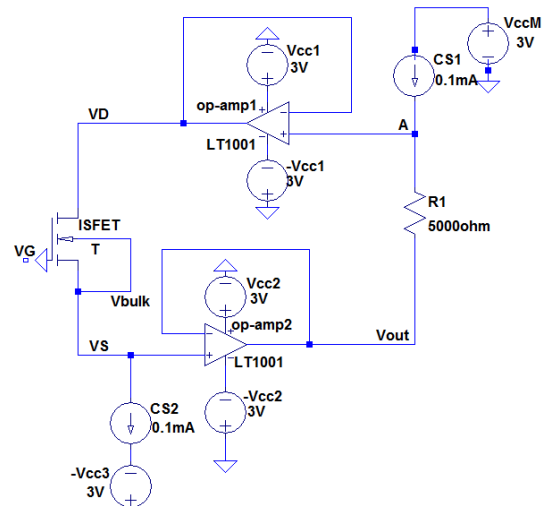

Fig.9. Schematic design using LTspice to get the simulation analysis

The data obtained from the simulation is shown in table.1 and the value at each node is clearly stated. The output voltage (Vout) from the circuit is -1.3065V. This is the voltage that represents the ionic concentration in the solution in case of using ISFET sensor. The voltage dropped at the resistor is the same as the voltage dropped at Vds. Resulting that the resistor is controlling the constant voltage of CVCC circuit at Vds terminal. A variable resistor is placed in the hardware instead of the complementary one to control the voltage at Vds. The value at each node was as expected and that proves that the CVCC circuit is able to measure the ionic concentration.

--- Operating Point ---		
V(vd):	-0.806503	voltage
V(vs):	-1.30651	voltage
V(a):	-0.806504	voltage
V(n002):	3	voltage
V(p001):	-3	voltage
V(vout):	-1.3065	voltage
V(p002):	3	voltage
V(n003):	-3	voltage
V(n001):	3	voltage
V(n004):	-3	voltage
I(Cs2):	0.0001	device_current
I(Cs1):	0.0001	device_current
Id(Isfet):	0.0001	device_current
Ig(Isfet):	0	device_current
Ib(Isfet):	-5.10003e-013	device_current
Is(Isfet):	-0.0001	device_current
I(R1):	0.0001	device_current

Table.1. Simulation result of CVCC circuit with the values at each node.

The reading from the hardware has many differences. On the other hand it is still correct. The ROIC was tested to measure three types of PH solution to determine the H<sup>+</sup> ions concentration. The reading is:

Solution	ROIC reading from ISFET
PH4	- 0.268V
PH7	-0.356V
PH10	- 0.383V.

Table.2. Reading of CVCC ROIC from ISFET sensor for different PH level.

As can be noted, three levels of PH solutions are having different voltages. These voltages are the presentation of the ionic concentration. By taking a known value of the concentration in the solution and calibrate it with the output voltage, an equation can be made to find other concentrations. Even though measuring the ionic concentration is not an easy thing to do since the concentrations keep changing due to temperature and other parameters. In addition, the circuit components might draw some of the voltages from the sensor. The CVCC still have a good sensitivity to read the ionic concentration from ISFET.

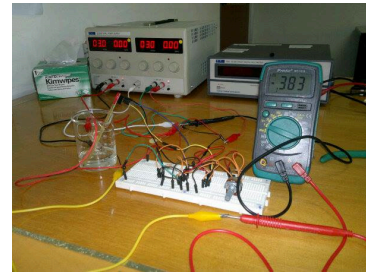

Fig.10. Hardware testing for CVCC circuit with ISFET to measure PH4 solution.

#### IV. ANALYSIS

The ISFET behavior under different conditions was tested to show how it reacted and how the result is affected by the conditions surrounding it or in the fabrication of IFET itself. The analysis made by the simulation varied different parameters. Since the ISFET was replaced with NMOS, the ionic concentration changes refer to changes in Vth. Therefore, Vth was changed to see how the Vout changes as well. Table2, shows the value of Vout at different Vth. The graph in Fig.11 is corresponding to Table.2. By increasing the Vth, the Vout decreased as well.

Vth	Vout
0.4	-1.0065
0.6	-1.2065
0.7	-1.3065
0.8	-1.4065
1	-1.6065
1.2	-1.80648
1.4	-2.00529
1.6	-2.0656
1.8	-2.06663
2	-2.06679

Table.3. Data obtained of Vth vs. Vout from the simulation software.

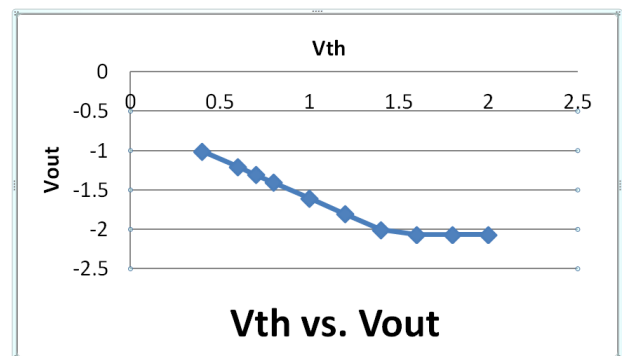

Fig.11. Graph result of Vth vs. Vout

Other condition was on varying the resistor value. In the hardware design, a variable resistor was implemented to control it manually to have more control on the circuit and the constant value Vds and as well as seeing how the output varies with the circuit. According to table.4, different value of R was tested to see what the output value of each. The graph was

plotted in Fig.12 according table.4. Form the graph, it can be obtained that the CVCC circuit interfaced with ISFET started to have a steady value when it is nearly 5Kohm. Therefore, one of the important parameters in the CVCC circuit to interface it with ISFET is that the resistor value has to be 5K or more. Even though the R value increases, the effect on the Vout is too small and negligible.

R	Vout
100	-2.0654
500	-2.06464
1000	-2.0628
3000	-1.44887
5000	-1.3065
7000	-1.29475
9000	-1.29245
15000	-1.28571
20000	-1.28026

Table.4. Data obtained of VR vs. Vout from simulation software

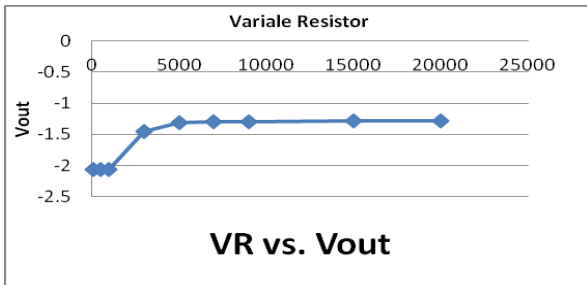

Fig.12. Graph result of VR vs. Vout.

ISFET might have different fabrication process and one of the things that might change is the length and width of the ISFET itself. Using the simulation software to test NMOS, the length and width can be varied. Table5. Shows the value of the width and length with ratio and how Vout changed due to width and length of the transistor. Fig.13 was plotted according to data in table.5. The result of this can lead to one thing that increasing the width and length ratio will increase the Vout from the ROIC CVCC.

W/L	ratio W/L	Vout
10u/1u	10	-1.1222
5u/ 1u	5	-1.3065
4u/1u	4	-1.39563
3u/1u	3	-1.54417
5u/2u	2.5	-1.66301
2u/1u	2	-1.84092
5u/3u	1.6667	-2.01666
3u/2u	1.5	-2.06225
4u/3u	1.3333	-2.06457
5u/4u	1.25	-2.06525

Table.5. Data obtained of Vth vs. Vout from the simulation software.

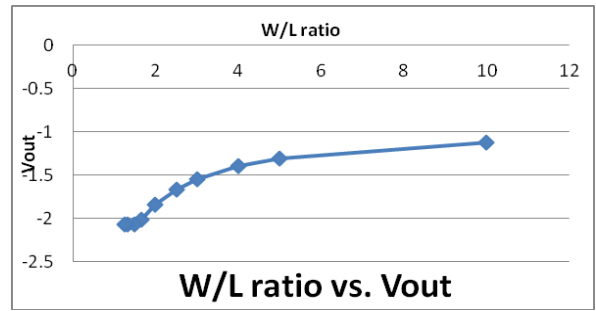

Fig.13. Graph result of W/L ratio vs. Vout.

Apart from testing the Vout of CVCC ROIC, there are other parameters that are tested. First was how the variable resistor controls the constant voltage Vds in the circuit. As explained before, the circuit was designed in a way to monitor the Vth changes of the circuit and nothing else. Therefore, Vds was set to certain value set by the resistor and preventing it from interfering with Vth value. Table.6 Shows what is the resistor value and Vds value correspond to it. to be noted that the current source is set to 100uA. The graph in Fig.14 shows a linear relationship between VR and Vds.

VR	VDS
1000	0.1V
3000	0.3V
5000	0.5V

Table.6. Data obtained of VR vs. Vout from simulation software

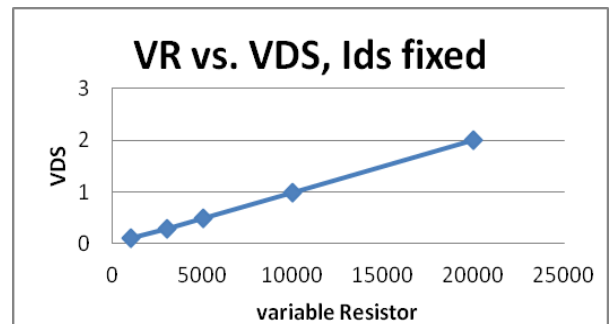

Fig.14. Graph result of VR vs. Vds.

The changes of the ionic concentrations change the Vth of the sensor. However in the circuit, these changes are seen at the VS terminal and sent to the Vout node. Table.7 shows different value of ionic concentration and what the value of Vds are. Fig15. Is the graph plotted to these data. It can be proven from the graph that the Vds keeps at constant voltage even if concentration increases.

VS	VDS
0.1V	0.5V
0.2V	0.5V
0.3V	0.5V

Table.7. Data obtained of Vth vs. Vout from the simulation software.



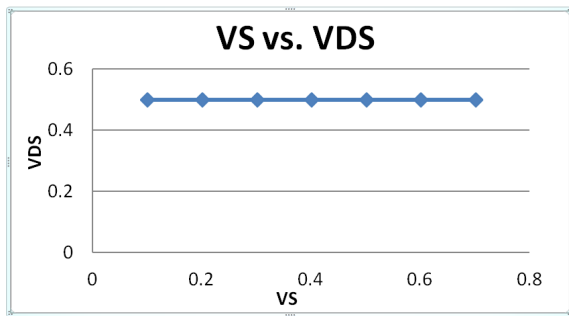

Fig.15. Graph result of VR vs. Vds.

Last investigation was on ISFET and how the temperature affected its output. From the graph in fig.16 shows the graph of temperature increases and the output from the ROIC. As the temperature increases, the Vout decreases. The ISFET reading has to be made at different times to know what the value is of each reading since the temperature changes the output.

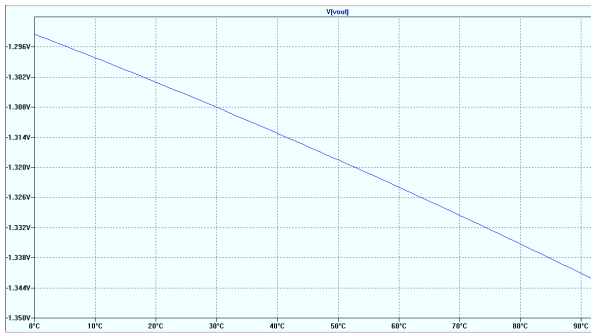

Fig.16. graph of temperature vs. Vout from the ROIC interfaced with ISFET.

## V. CONCLUSION

Over all, ISFET is an effective sensor to detect the ionic concentration in the solution. The CVCC ROIC was designed and built to interface with ISFET. The CVCC circuit proved that it has the ability to measure the ionic concentration. The ISFET with ROIC has been tested under different conditions as well as different fabrication of ISFET and different value of components of CVCC ROIC. To conclude, the ROIC that is CVCC, has the ability to interface highly with ISFET to measure the ionic concentration and thus will give huge benefits in many fields of research and developments.

## ACKNOWLEDGMENT

The author of this paper would like to express his great gratitude to DR. wan Fazlidah Halim Abdullah for her help, support, advice and guidance. He would like also to thank FKE of UiTM Shah Alam to allow him to use their labs and equipments to complete his work.

## REFERENCES

[1] Bergveld, P., "Development of an Ion-Sensitive Solid-State Device for Neurophysiological Measurements," *Biomedical*

*Engineering, IEEE Transactions on*, vol.BME-17, no.1, pp.70,71, Jan. 1970.

[2] P. Bergveld, "Thirty years of ISFETOLOGY: What happened in the past 30 years and what may happen in the next 30 years," *Sensors and Actuators B: Chemical*, vol. 88, pp. 1-20, 2003.

[3] Toumazou, C.; Georgiou, P., "Piet Bergveld - 40 years of ISFET technology: from neuronal sensing to DNA sequencing," *Electronics Letters*, vol.47, no.26, pp.S7,S12, December 22 2011.

[4] Ravezzi, L.; Conci, P., "ISFET sensor coupled with CMOS read-out circuit microsystem," *Electronics Letters*, vol.34, no.23, pp.2234,2235, 12 Nov 1998.

[5] P. Bergveld, "ISFET, Theory and Practice," in *IEEE Sensor Conference*, Toronto, 2003, pp. pp 9-10.

[6] Rani, R.A.; Syono, M.I.; Marzuki, M.R., "Operational of ISFET as a pH Sensor by Using Signal Modulated Reference Electrode," *Information and Multimedia Technology, 2009. ICIMT '09. International Conference on*, vol., no., pp.548,550, 16-18 Dec. 2009

[7] Abdullah, W.F.H.; Othman, M.; Ali, M.A.M., "Chemical field-effect transistor with constant-voltage constant-current drain-source readout circuit," *Research and Development (SCORed), 2009 IEEE Student Conference on*, vol., no., pp.219,221, 16-18 Nov. 2009.

[8] Hon-Sum Wong; White, M.H., "A CMOS-integrated 'ISFET-operational amplifier' chemical sensor employing differential sensing," *Electron Devices, IEEE Transactions on*, vol.36, no.3, pp.479,487, Mar 1989.

[9] Humenyuk, I.; Palomar, S.; Lagrange, D.; Assie, S.; Franck, B.; Marcoul, P.; Medale, D.; Martinez, A.; Temple-Boyer, P., "Study On pH-ISFET Temperature Effect Using Implemented MOS Transistor," *Mixed Design of Integrated Circuits and System, 2006. MIXDES 2006. Proceedings of the International Conference*, vol., no., pp.528,532, 22-24 June 2006.

[10] Mayorga V., O.; Aldana A., G.; Rodriguez P., H., "Microcontroller-based system for multiple ISFET characterization using a single reference electrode," *Engineering in Medicine and Biology Society, 1997. Proceedings of the 19th Annual International Conference of the IEEE*, vol.6, no., pp.2361,2364 vol.6, 30 Oct-2 Nov 1997.

[11] Liu, Y.; Al-Ahdal, A.; Georgiou, P.; Toumazou, C., "Minimal readout scheme for ISFET sensing arrays based on pulse width modulation," *Electronics Letters*, vol.48, no.10, pp.548,549, May 10 2012.

[12] Jamasb, S.; Churchill, J.N.; Collins, S.D.; Smith, R.L., "Accurate continuous monitoring using ISFET-based biosensors based on characterization and modeling of drift and low frequency noise," *Engineering in Medicine and Biology Society, 1998. Proceedings of the 20th Annual International Conference of the IEEE*, vol.6, no., pp.2864,2867 vol.6, 29 Oct-1 Nov 1998.

[13] Rani, R.A.; Sidek, O., "ISFET pH sensor characterization: towards biosensor microchip application," *TENCON 2004. 2004 IEEE Region 10 Conference*, vol.D, no., pp.660,663 Vol. 4, 21-24 Nov. 2004.

[14] Hashim, U.; Haron, M. N., "Design of digital display system for ISFET pH sensor by using PIC microcontroller Unit (MCU)," *Quality Electronic Design, 2009. ASQED 2009. 1st Asia Symposium on*, vol., no., pp.148,152, 15-16 July 2009.