

# **TRANSFORMERLESS POWER SUPPLY FOR LOW VOLTAGE APPLICATION**

**This report is presented in partial fulfilment for the award of the  
Bachelor of Electrical Engineering (Hons.)  
Universiti Teknologi MARA**



**FAZLINA HANIM BT NORDIN  
Faculty of Electrical Engineering  
UNIVERSITI TEKNOLOGI MARA  
40450 SHAH ALAM, SELANGOR**

# ACKNOWLEDGEMENT

## **In the Name of Allah S.W.T**

All praises be to Almighty Allah S.W.T, the Merciful and Beneficent for the strength and blessing me throughout the entire research and completion of this project. Peace is upon our prophet Muhammad S.A.W; whose has given light to mankind.

I would like to express my sincere gratitude to my supervisor, Prof. Madya Zulkifli B. Abd. Majid for his support, suggestion, guidance, comments and encouragement during the preparation of this project. Also, I would like to thank all the laboratory personnel for their involvement and assistance in making this project successful.

My appreciation also goes to my beloved parent, Almarhum En. Nordin B. Md Noor and Pn. Che Liah Bt. Ismail for their guidance and love in nurturing me to be who I am today. Also to my brothers and sisters through their caring, motivations and understanding, they have taught me to have the courage to believe in myself even more.

My sincere and deepest thanks to all my colleagues, friends, lecturers, staffs of the Faculty of Electrical Engineering for their support and cooperation for completion of this thesis.

## ABSTRACT

In most non-battery applications, the power supply to the electronic circuits can be built using a step-down transformer connected to the ac supply line to step the ac voltage to desired amplitude, then rectifying that ac voltage, filtering with a capacitor or RC filter, and finally regulating the dc voltage using zener or an IC regulator. However, in many smaller low-cost applications, the cost size of the transformer becomes the key factor in the system. Under these circumstances, the step-down transformer is normally not used in order to reduce the cost as well as the size. The power supply is a simple one-way rectifier with very few components. The output voltage is regulated by using a zener diode. Despite its simplicity and low cost, it is still able to deliver enough current to the electronic and application circuit.

In this thesis report presents a proposed a design of transformerless power supply for low voltage application. The scope of work will involve the design, simulation (using PSPICE), fabrication and test of the circuit. The main target is to achieve a low cost in overall design and fabrication without sacrificing the performance.

The circuit presented in this paper is a transformerless power supply capable of providing 9V at 50mA, but can be easily modified for other output voltages.

# TABLE OF CONTENTS

CHAPTER	DESCRIPTION	PAGE
	<b>DECLARATION</b>	i
	<b>ACKNOWLEDGEMENT</b>	ii
	<b>ABSTRACT</b>	iii
	<b>TABLE OF CONTENTS</b>	iv
	<b>LIST OF FIGURES</b>	vii
	<b>LIST OF TABLES</b>	ix
	<b>LIST OF ABBREVIATIONS</b>	x
<b>1</b>	<b>INTRODUCTION</b>	1
	1.1 Introduction	1
	1.2 Scope of Work	2
	1.3 Scope of Thesis	3
<b>2</b>	<b>BASIC POWER SUPPLY</b>	4
	2.1 Introduction	4
	2.2 The Basic Power Supply Overview	4
<b>3</b>	<b>TRANSFORMERLESS POWER SUPPLY OVERVIEW</b>	6
	3.1 Introduction	6
	3.2 Basic Transformerless Power Supply	6
	3.3 Rectification (AC to DC)	7
	3.3.1 Half Wave Rectifier	7

# CHAPTER 1

## INTRODUCTION

### 1.1 Introduction

The electronic power supply takes commercial ac voltage and converts it to dc voltage demonstrated in Figure 1. Internally the power supply consists of several electronic devices.

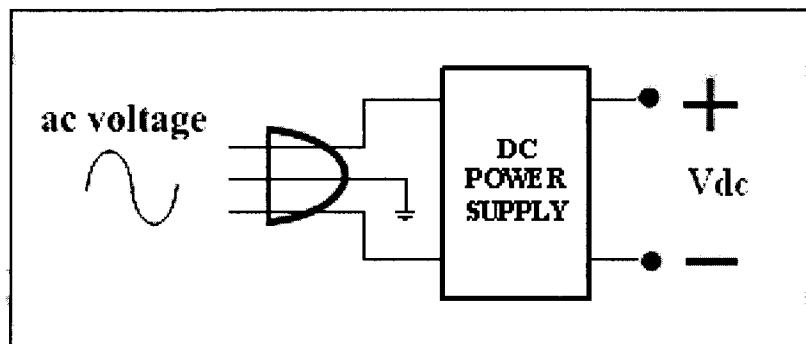

Figure 1.1: Block diagram of a DC power supply

Power supplies are built into equipment where commercial ac is available and dc voltage is required. This is a very convenient and inexpensive way to provide dc voltage for continuous use. Batteries are much more expensive and need replacing or recharging on a regular basis. A power supply produces dc voltage as long as the circuit has ac voltage into it. Also, different dc voltages can be provided by the power supply to feed different circuits in the equipment that require different dc voltages.

In most non-battery applications, the power to the electronic equipment is normally supplied using a wall mounted transformer, which then rectified, filtered