

The Development of an IoT-Based Air Quality Monitoring System Using the Blynk Application

Nurzaid Muhd Zain^{1*}, Muhammad Amir Rusyaidi Mohd Rozi², Mahfudzah Othman³, Zulfikri Paidi⁴

^{1,2,3,4}College of Computing, Informatics and Mathematics, Universiti Teknologi MARA Perlis Branch, Arau Campus, 02600 Arau, Perlis, Malaysia

ARTICLE INFO

Article history:

Received: 31 January 2024

Revised: 13 February 2024

Accepted: 14 February 2024

Online first: 1 March 2024

Published 1 March 2024

Keywords:

Air Quality

IoT

Monitoring System

Blynk Application

DOI:

10.24191/jcrinn.v9i1.426

ABSTRACT

This paper discusses designing and developing an Arduino-based air quality monitoring system utilizing the Blynk application. The aim is to design an IoT-based air quality monitoring system that allows users to check current air quality precisely and promptly via their mobile phones in real-time. The construction of the application involves three phases: design, prototype development, and system testing. The design and development phases involved various setups and configurations of MQ135 gas sensor and microcontroller NodeMCU to assess air quality in parts per million (ppm) and allow data transmission via Wi-Fi to users' mobile phones with the Blynk application. System testing has shown accurate results in the MQ135 gas sensor among five different gases, which led to the efficiency of the prototype system in detecting air quality based on air quality level (ppm). As a result, the Red LED illuminates, and the Buzzer emits a warning sound when the air pollution level exceeds 150ppm.

1. INTRODUCTION

Air pollution is a significant contaminant that is wreaking havoc on the environment in this age of globalization where the problem of global warming results from air pollution, which exacerbates natural disasters and puts our planet at risk (Carrington, 2018). Air pollution is the presence of gases, liquids, or particles in the atmosphere that alter the biological and chemical composition of the atmosphere (Mustakim et al., 2023). Mustakim et al. (2023) added that air pollution is caused by smoke emissions from vehicles, industrial facilities that emit smoke or toxins, and the uncontrolled use of charcoal or wood stoves, which can have many negative consequences for all life on the planet.

According to Kwan et al. (2023), air pollution has various adverse effects on humans, including damage to the respiratory system. When pollutants and superfluous gases pollute the air, it becomes difficult for humans to breathe. For instance, suffocating gases such as carbon monoxide can cause drowsiness, exhaustion, and diminished lung function by suffocating the blood's oxygen delivery system (Kwan et al., 2023). Additionally, plants also suffer necrosis and stunted growth due to the consequences. Inhaling

^{1*} Corresponding author. *E-mail address:* nurzaid@uitm.edu.my
<https://doi.org/10.24191/jcrinn.v9i1>

polluted air or ingesting toxic plants will cause harm to animals as well (Sylvester et al., 2023). In a study conducted by the World Health Organization (WHO), it has been discovered that air pollution claims the lives of three million people each year. It represents a threefold increase in the number of collisions that they cause. As a result of globalization, the World Health Organization (WHO) has highlighted and taken air pollution seriously, initiating several initiatives to address the problem (WHO, 2023).

For instance, an initiative by Dhingra et al. (2019) introduces IoT-Mobair, a mobile application that aids users in forecasting the level of air pollution in customized surrounding areas. By using ESP8266 and air pollution index (API) values integrated with the mobile application, the system will display "air pollution" that can assist people suffering from chronic respiratory illness. Besides that, a project that utilizes a microcontroller based on Arduino technology to monitor air quality was developed and implemented by Pal et al. (2017) to display the pollution level in parts per million (ppm). To detect harmful gases in the environment, the MQ135 gas sensor and a NodeMCU board connected to a firebase database can be used together (output). Via this system, the pollution level in an Android application can be displayed with the help of a Firebase database. It will also display the air quality in parts per million (ppm) and indicate whether it is good, dangerous, or weak. The accuracy and efficiency of wireless transmission have both improved due to the project. This project will be highly beneficial if it successfully monitors air pollution in our surrounding area. However, this application has limitations in that it is limited to a single location, and the application interface could be more organized.

Meanwhile, in Malaysia, it has been reported that the air quality is deteriorating. Malaysia's Ministry of Natural Resources and Environment reports that various factors, including development activities, industrial development, transportation effects, power generation, widespread open burning, and forest fires, cause air pollution (Mustakim et al., 2023). In recent years, an increasing number of people have become aware of the harmful effects of air pollution on their health. Maintaining a healthy API reading is critical to protect human health and avoid problems. When API values increase, it indicates that the air is hazardous to humans. If the API value is hazardous, it can have various adverse health effects on humans (Payus et al., 2022; Mazlan et al., 2023).

Nevertheless, the complexity of operating genuine air pollution detection systems and the system's cost are significant issues (Malleswari & Mohana, 2022). Additionally, the system is extensive, necessitating a sizable staff (Malleswari & Mohana, 2022). Moreover, governments and large corporations with industrial holdings own most of these systems used to monitor air quality. Malaysia's government focuses on health issues as a critical challenge in urban and rural areas as air quality deteriorates (Nawawi et al., 2022). However, the previous API system flaws can now be addressed by implementing several enhancements. As a result, this project was conceived and designed to develop a more straightforward, affordable, and secure air quality monitoring system based on the internet-of-things (IoT) concept with the Arduino and Blynk applications.

2. BACKGROUND OF STUDY

2.1 The Internet of Things (IoT)

The Internet of Things, or IoT, is a cutting-edge technology that functions on several levels and can enable an intelligent network. Howells (2019) claimed that IoT technologies, when combined with sensors and ubiquitous mobile networks, will potentially provide cost-effective methods of improving the air quality in our surroundings. For example, a mobile application with IoT features, such as IoT-Mobair by Dhingra et al. (2019), can publish values of the API in real-time, publish API forecasts daily, and

recommend the best time to engage in outdoor activities with special reports on air quality measurements. These reports were generated based on the user's location and air quality maps.

Additionally, Al Ahasan et al. (2018) have designed and implemented an Arduino-Based Air Quality Monitoring and Air Pollution Monitoring System capable of measuring and sharing air quality in various settings, including in urban and rural areas. The MQ-135 air quality sensor was used to determine the pollution level in each area. This microcontroller-based sensor detects various gases, including O₃, CO, CO₂, and NO₂. The Arduino system will be wired to a computer, and the data collection process begins with the sensor and continues with the Arduino microcontroller. The data will then be transferred to specialized software for real-time documentation and plotting. The fact that the hardware and software in this system are small and simple to operate is one factor contributing to its ability to detect a large amount of gas effectively.

2.2 The Blynk Application

Lincy and Sasikala (2021) described the Blynk application as a platform that allows users to quickly create interfaces for controlling and monitoring their hardware projects from an iOS or Android device. Blynk is free and allows users to create project dashboards by downloading the Blynk app and placing buttons, sliders, graphs, and other widgets on the screen after installation (Lincy & Sasikala, 2021). The widgets allow the user to control pins by turning them on and off or displaying sensor data. Using the Blynk application and the Arduino board, an Internet of Things-enabled air pollution meter can monitor air quality on a user's smartphone. Ong (2021) added that Blynk is an Internet of Things (IoT) platform that allows users to control Arduino, Raspberry Pi, and other similar devices anywhere in the world. A digital dashboard for users' smartphones, provided by Blynk, displays real-time air quality readings for the immediate surroundings in this project. The Blynk server oversees all communication between the smartphone and the hardware components. Several professional businesses, such as the beer brewing industry, have adopted Blynk as a standard operating procedure (Ong, 2021). This project will utilize the Blynk application, sensors, and Wireless Sensor Network (WSN) technologies. The WSN technology used in this project is intended to provide warnings and notifications about the current air pollution rates if they are elevated.

2.3 Measuring Air Pollution Using the Gas Sensor

Based on the project done by Dhingra et al. (2019), the air quality monitoring system comprises gas sensors continuously monitoring the air. In controlled and uncontrolled situations, it can detect pollutants in oxidised or reduced gases inside and outdoors Dhingra et al. (2019). Furthermore, Dhingra et al. (2019) added that gas detectors are frequently combined with access control to detect gas in a specific area. When a leak occurs or the air quality deteriorates, users may be informed by on-site gas detectors, allowing them to evacuate the area (Dhingra et al., 2019). According to Idrees and Zheng (2020), numerous gases can threaten biological life, including humans and animals, making the technology highly beneficial and necessary. Gas detectors can detect flammable and poisonous gases, oxygen depletion, and flammable and hazardous gases. This type of technology is widely utilised in industry and is frequently found on-location, such as oil rigs, to monitor industrial processes and emerging technologies, such as photovoltaics (Idrees & Zheng, 2020).

This study made use of the MQ135 air quality sensor. This sensor detects various substances, including ammonia, nitrogen oxides, alcohol, benzene, smoke, and carbon dioxide. It is suitable for office and industrial use. The MQ135 gas sensor detects smoke or other dangerous gases due to its outstanding sensitivity to ammonia, Sulphur, benzene vapors, smoke, and other hazardous gases. It is a low-cost sensor that is well-suited for air quality monitoring applications.

2.4 Microcontroller - NodeMCU ESP8266

Microcontrollers are small electronic devices with a CPU, a small amount of memory, and programmable input-output peripherals dedicated to completing a single task and running a single application (Siregar et al., 2022). Experts say microcontrollers are a crucial component of embedded systems (Sobrinho, 2020). A microcontroller is simply a low-cost, single-chip computer with a few additional features that can be found in various products, including those used in the household, telecommunications, the car industry, and aerospace applications (Sobrinho, 2020). It is common for designers to use a microcontroller to gather data from several sensors, analyze it, and launch a sequence of activities (Siregar et al., 2022).

According to Astutik et al. (2019), NodeMCU is an almost clean microcontroller with an embedded Wi-Fi ESP8266 module. The ESP 8266 was chosen for this project since it is the most cost-effective Wi-Fi MCU. The ESP 8266 is the most advanced Wi-Fi system available today, using 5mm x 5mm. Moreover, NodeMCU is an open-source firmware that may be used to build Internet of Things (IoT) devices. It can potentially be very beneficial (Astutik et al., 2019). The ESP8266's characteristics include intense onboard processing and adequate storage to coordinate with sensing devices while requiring little programming and loading when used with GPIOs (General Purpose Input/output) (Abdul Jalil et al., 2021).

3. METHODOLOGY

This study involved three main phases, which are i) design, ii) prototype development, and iii) system testing. The elaboration of each phase is described as follows:

(i) Design

The primary goal is to design an air monitoring quality system that can detect air quality utilizing the Blynk application over a WSN connection, collect data in a centralized location, and alter people's impressions of the surrounding air environment. Therefore, an architecture of the system with hardware and software requirements is being designed and proposed, as depicted in Fig. 1.

The system's hardware requirements are the NodeMCU ESP8266, gas sensor MQ135, buzzer, LED, and 220-ohm resistors. Meanwhile, Arduino IDE and Blynk application are the required software for the system development. This air quality monitoring system is designed to allow users to check current air quality precisely and quickly via the Blynk App on their mobile phones in real time.

The project will assess air quality in parts per million (ppm) by connecting an MQ135 gas sensor to a microcontroller NodeMCU and transmitting data through Wi-Fi. Additionally, users can monitor air quality using their phones and the Blynk App.

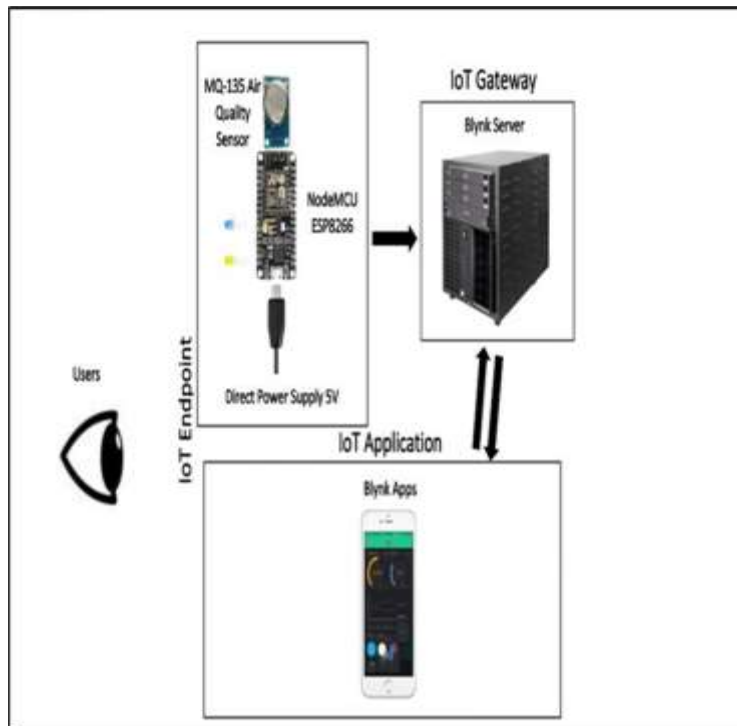

Fig 1. Proposed architecture of the air quality monitoring system

(ii) Prototype Development

Developing an air monitoring system with the Blynk application entails several multi-step techniques for efficient construction. The first step involves NodeMCU ESP8266 setup and configuration, followed by the MQ-135 Gas Sensor setup and configuration. After both setup and configurations were successfully configured, the Blynk application was constructed to simplify communicating with a microcontroller via Wi-Fi. This application was created specifically for numerous Internet of Things (IoT) applications. It can remotely control hardware, display sensor data, store data, visualize data, and perform various other tasks. The Blynk application for Android and iOS makes it easier to manage the MQ135 gas sensor, LED lights, and buzzer. Additionally, this air quality monitoring system can only be monitored and operated effectively via smartphone.

(iii) System Testing

The MQ135 gas sensor's sensitivity is tested using the measurement accuracy of specific locations and materials. Five test objects will be used to determine the MQ135 gas sensor's sensitivity, including carbon dioxide gas from automobiles, alcohol from hand sanitizer, butane gas from a lighter, smoke from burning paper, and aerosol from mosquito repellent. Additionally, the distance is varied to determine the sensor's sensitivity. The Blynk application will then reveal all reading results.

4. RESULTS AND DISCUSSION

4.1 Block Diagram and Fritzing Diagram

Based on the design of the system's architecture in Fig. 1, the hardware and software components of the system and the flow and operations associated with them are then represented by a block diagram and

a fritzing diagram. In electronics, block diagrams describe the system and its transition configuration, and they are also used to represent the system. Meanwhile, the fritzing diagram is prepared to illustrate the connection of the prototype's hardware components. Fig. 2 and Fig. 3 show the block diagram and fritzing diagram designed for the air quality monitoring system.

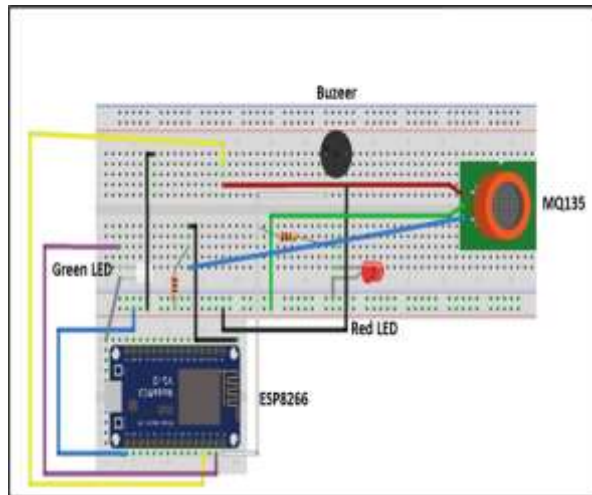

Fig. 2. Block diagram for the air quality monitoring system

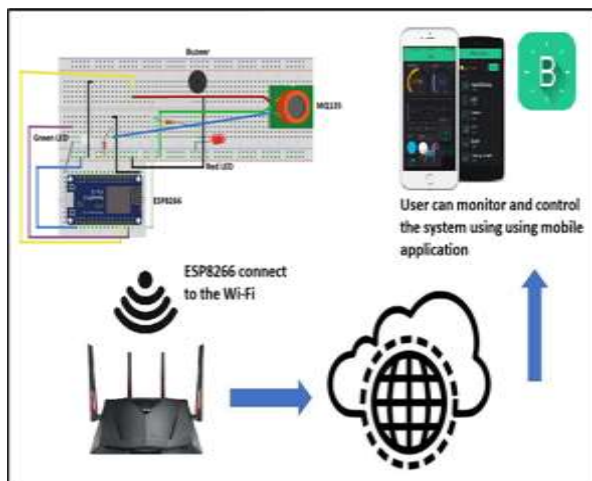

Fig. 3. Fritzing diagram for the air quality monitoring system

4.2 The assembled prototype of the air quality monitoring system

A dedicated space was required to house the breadboard and the NodeMCU ESP8266 to create a prototype for this system. In this instance, a simple box was used to prototype the air quality monitoring system. The MQ135 Gas Sensor was constructed in a suitable medium-sized box. A gas sensor was mounted at the top of the box, which serves as this project's focal point. The box inside contains the breadboard, buzzer, NodeMCU ESP8266, and Red/Green LEDs, while the outside contains only the MQ135. The transparent mounting board glows the same colour as the green and red LED lights that indicate the current level of air quality. A hole was drilled in the bottom of the prototype to allow the USB

<https://doi.org/10.24191/jcrinn.v9i1>

Micro B cable from the power supply to be connected to the NodeMCU ESP8266 board inside the box. Another hole was drilled in the bottom of the prototype to allow the USB Micro B cable from the power supply to be connected to the NodeMCU ESP8266 board inside the box. Fig. 4 shows the assembled air quality monitoring system prototype, where the Blynk application output displays air quality, live ppm, and pollution level detected from the sensors.

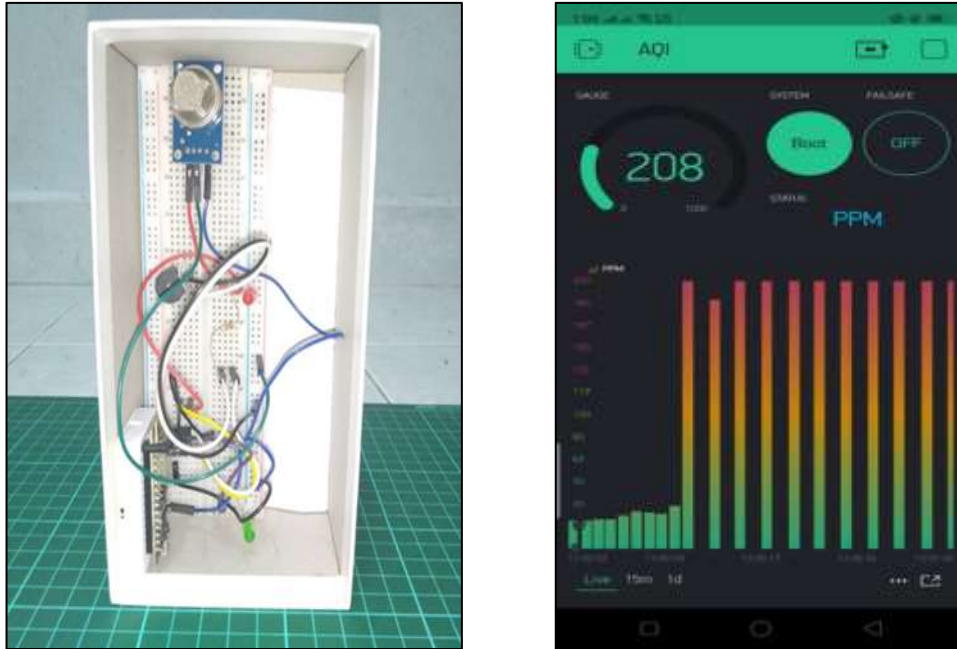

Fig. 4. The assembled air quality monitoring system prototype and the Blynk application output with air quality, ppm value and pollution level display

4.3 The MQ135 gas sensor's sensitivity testing

The MQ135 gas sensor test findings were calculated as an average of the ten times it is tried and reported in the manner described in Table 1.

Table 1. MQ135 Gas Sensor Sensitivity Test

No	Type of Gas	Test Object	Accuracy	Value (ppm)
1	Carbon Dioxide	Car	Accurate	243
2	Alcohol	Hand Sanitizer	Accurate	356
3	Butane	Lighter	Accurate	439
4	Smoke	Burning Paper	Accurate	218
5	Aerosol	Mosquito Repellent	Accurate	331

According to the data in Table 1, the MQ135 gas sensor provides high and accurate readings for all the gases tested. Specifically, temperature and humidity are both critical factors in determining the value of the air pollution index, which is utilized by the MQ135 gas sensor. Since the MQ135 sensor detects gases in the air environment through heat, this affects accuracy. If the sensor is heated, its value can be determined by measuring the reaction of burning gas toward a hot plate. When the MQ135 sensor is exposed to high

<https://doi.org/10.24191/jcrinn.v9i1>

humidity, the reading will be lower, while when the sensor is exposed to low humidity, the reading will be higher.

4.4 The prototype system testing

The functioning of each hardware component produced to ensure the operation of the Air Quality Monitoring System is tested using a prototype. This test is performed to determine whether the prototype output can be seen on the Blynk Application display and whether the system can provide an emergency alert to the user. It was also to monitor whether the prototype could deliver alerts via buzzer when air quality levels surpassed the system's preset limits of more than 115 ppm. In addition, because of the network latency of the internet connection, the output data in the Blynk application will constantly change. The output from the Blynk application for air quality, live ppm, and pollution level in Fig. 4 is similar to the results shown in Table 2. All the other sensors and hardware are in good condition.

Table 2. Prototype System Testing

No	Air Quality Level (ppm)	Red LED	Buzzer	Results
1	115	Off	Off	Success
2	208	On	On	Success
3	184	On	On	Success
4	316	On	On	Success

5. CONCLUSION

In conclusion, the project was a success and met the project objectives. The IoT-based air quality monitoring system was designed and developed using the Blynk application, which can provide real-time results and be more cost-effective. Furthermore, the prototype developed in this project functions well as a real-time air quality identifier system. The MQ135 gas sensor is placed in the target area to periodically determine the pollution rate. The Red LED can illuminate, and the Buzzer emits a warning sound when the air pollution level exceeds 150 ppm, proving the efficiency of the prototype system in detecting air quality based on air quality level (ppm).

Nevertheless, the prototype was not adequately tested in the proper location, such as the factory area, by not conducting a face-to-face demonstration. Furthermore, due to financial constraints, air quality monitoring is limited to monitoring air quality levels only. The project can be further improved by including an LCD output, making it easier for users to see the readings and ensuring that the owner remains informed about air quality while the system operates. Furthermore, this project can be improved by adding air quality sensors, such as MQ2, MQ5, and MQ7. Additionally, increasing the amount of sensor gas used will be necessary to improve and enhance the level of air quality monitoring from various angles.

6. ACKNOWLEDGMENTS

The authors thank the Universiti Teknologi MARA (UiTM) Perlis Branch, Arau Campus, Malaysia, for supporting the project's development. We would also like to thank ISTECoSQA 2023 for the opportunity to present our research findings.

7. CONFLICT OF INTEREST STATEMENT

The authors agree that this research was conducted without any self-benefits or commercial or financial conflicts and declare the absence of conflicting interests with the funders.

8. AUTHORS' CONTRIBUTIONS

Author 1 carried out the research and wrote and revised the article. Author 2 conceptualised the central research idea and provided the theoretical framework. Author 3 supervised the research progress, and Author 4 was responsible for the prototype development and analyses of results. Authors 1 and 2 anchored the review and revisions and approved the article submission.

9. REFERENCES

- Abd Jalil, A.M., Mohamad, R., Anas, N.M., Kassim, M & Suliman, S.I. (2021). Implementation of vehicle ventilation system using NodeMCU ESP8266 for remote monitoring. *Bulletin of Electrical Engineering and Informatics*, 10(1), pp. 327-336.
- Al Ahasan, M.A., Roy, S, Saim, A.H.M., Akter, R., & Hossain, M.Z. (2018). Arduino-Based Real-Time Air Quality and Pollution Monitoring System. *International Journal of Innovative Research in Computer Science & Technology*, 6 (4), pp. 81–86. <https://doi.org/10.21276/ijircst.2018.6.4.8>.
- Astutik, Y., Murad, M., Putra, G.M.D. & Setiawati, D. A. (2019). Remote monitoring systems in greenhouse based on NodeMCU ESP8266 microcontroller and Android. *In AIP Conference Proceedings (Vol. 2199, No. 1)*. AIP Publishing. <https://doi.org/10.1063/1.5141286>
- Carrington, D. (Ed.) (2018). *Air pollution*. Retrieved May 4, 2023, from <https://www.theguardian.com/environm2023,2018/nov/05/air-pollution-everything-you-should-know-about-a-public-health-emergency>.
- Dhingra, S., Madda, R., Gandomi, A.H., Patan, R. & Daneshmand, M. (2019). Internet of Things Mobile – Air Pollution Monitoring System (IoT-Mobair). *IEEE Internet of Things Journal*, 6(3), 5577–5584. <https://doi.org/10.1109/JIOT.2019.2903821>.
- Howells, J. (2019). Can IoT help us tackle air pollution? *Orange Business Services*. Retrieved May 4, 2023, from <https://www.orange-business.com/en/blogs/can-iot-help-us-tackle-air-pollution>.
- Idrees, Z. & Zheng, L. (2020). Low-cost air pollution monitoring systems: A review of protocols and enabling technologies. *Journal of Industrial Information Integration*, 17, 100123. <https://doi.org/10.1016/j.jii.2019.100123>
- Kwan, S.C., Zakaria, S., Ibrahim, M.F., Mahiyuddin, W.R.W., Sofwan, N.M., Wahab, M.I.A., Ahmad, R.D.R., Abbas, A.R., Woon, W.K. & Sahani, M. (2023). Health impacts from TRAPs and carbon emissions in the projected electric vehicle growth and energy generation mix scenarios in Malaysia. *Environmental Research*, 216, 114524. <https://doi.org/10.1016/j.envres.2022.114524>
- Lincy, F.A. & Sasikala, T. (2021). Smart dustbin management using IOT and Blynk application. *In 2021 5th International Conference on Trends in Electronics and Informatics (ICOEI)* (pp. 429-434). IEEE Xplore. <https://10.1109/ICOEI51242.2021.9452988>
- Malleswari, S.M.S.D. & Mohana, T.K. (2022). Air pollution monitoring system using IoT devices. *Materials Today*. In Kumar & Shrivastava (Eds.). *Materials today: Proceedings: 5th International Conference on Trends in Electronics and Informatics (ICOES)* (pp. 1147–1150). ScienceDirect. <https://doi.org/10.1016/j.matpr.2021.07.114>
- Mazlan, N., Zaki, N., Narashid, R., Talib, N., Manokaran, J., Arshad, F., Fauzi, S., Dom, N., Valipour, M, Dambul, R., & Blenkinsop, S. (2023). COVID-19 restriction movement control order (MCO) impacted emissions of peninsular Malaysia using Sentinel-2a and Sentinel-5p satellite. *Earth Systems and Environment*, 7(1), 347–358.

- Mustakim, N., Ul-Saufie, A.Z., Shaziayani, W.N., Noor, N.M. & Mutalib, S. (2023). Prediction of Daily Air Pollutants Concentration and Air Pollutant Index Using Machine Learning Approach. *Pertanika Journal of Science & Technology*, 31(1), 123 -135.
- Nawawi, M. N., Samsudin, H., Saputra, J., Szczepańska-Woszczyna, K., & Kot, S. (2022). The effect of formal and informal regulations on industrial effluents and firm compliance behavior in Malaysia. *Production Engineering Archives*, 28(2), 193–200.
- Ong, D. (2021, June 8). Brand new Blynk IoT Platform released, with official support for Wio Terminal! *Latest Open Tech from Seeed Studio*. Retrieved August 2023 at <https://www.seeedstudio.com/blog/2021/06/03/brand-new-blynk-iot-platform-released-with-official-support-for-wio-terminal/>.
- Pal, P., Gupta, R., & Tiwari, S. (2017). Iot Based Air Pollution Monitoring System Using Arduino. *International Research Journal of Engineering and Technology (IRJET)*, 04(10), 2395–0056. <https://www.irjet.net/archives/V4/i10/IRJET-V4I10207.pdf>.
- Payus, C.M., Syazni, M.N., & Sentian, J. (2022). Extended air pollution index (API) as tool of sustainable indicator in the air quality assessment: El-Nino events with climate change driven. *Heliyon*, 8(3), e09157.
- Siregar, I. M., Siagian, N. F., & Siregar, V. M. M. (2022). A Design of an Electric Light Control Device Using Arduino Uno Microcontroller-Based Short Message Service. *Internet of Things and Artificial Intelligence Journal*, 2(2), 98–110.
- Sobrinho, A. S. F. (2020). An Embedded Systems Remote Course. *Journal of Online Engineering Education*, 11(2), 01-07.
- Sylvester, C.I., Adams, O.I., Baturh, Y., Glory, R. (2023). Chapter 7 - Impact of air quality as a component of climate change on biodiversity-based ecosystem services. In Srivastav, A., Dubay, A., Kumar, A., Narang, S. S., & Khan M. N. (Eds.), *Visualization techniques for climate change with machine learning and artificial intelligence* (pp.123-148). Springer. <https://doi.org/10.1016/B978-0-323-99714-0.00005-4>.
- WHO (2023). *WHO ambient air quality database, 2022 update: Status report*. World Health Organization, pp 1-34. Retrieved May 4, 2023, from <https://www.who.int/publications/i/item/9789240047693>.



© 2024 by the authors. Submitted for open access publication under the terms and conditions of the Creative Commons Attribution (CC BY) license (<http://creativecommons.org/licenses/by/4.0/>).