

SPMC – STUDY OF PASSIVE FILTER FOR APPLICATION ON THE SPMC OPERATE AS AC CHOPPER

Muhammad Azizi Bin Mohd Selam
Faculty of Electrical Engineering
Universiti Teknologi MARA
40450, Shah Alam, Malaysia
jje_2835@yahoo.com

Abstract:- This paper present application of single phase matrix converter (SPMC) as AC chopper by using different type passive filter design. MATLAB/simulink 7 will be use to develop the simulation model of the SPMC without and with filter and to study the behavior of the proposed converter. Sinusoidal pulse width modulation (SPWM) is used for a wave technique. Safe commutation was developed to avoid voltage spikes. To avoid this kind of problem, filter design represented by low pass RC filter and LC filter. Results of simulation are presented to verify the proposed technique is feasible.

I. INTRODUCTION

Matrix converter is an advanced topology that could perform many different converter functions. This topology capable of converting ac to ac, ac to dc, dc to ac and dc to dc. SPMC is used to step-up frequency, transformation and rectification. The single phase input and output are connecting with four bidirectional switches at the intersection.

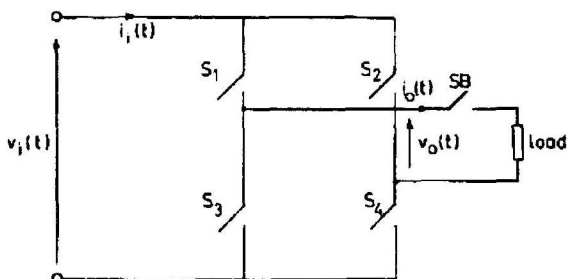

The basic of matrix converter are from a special class of Cycloconverter that was developed in the early 1930s [1]. In 1976, the ac-ac matrix converter topology was first investigated [2]. Venturini and Alessina was

introduced three-phase matrix converter (TPMC) in 1980. Obviously deal with three-phase circuit topology, control and protection. Zuckerberger was first realized that the single-phase variant denoted as SPMC [3]. Other SPMC studies include those by Saiful, Abdollah Khoei and Hossieni.

Theoretically the switching sequence in the SPMC must be instantaneous and simultaneous. Unfortunately it is impossible for practical realization due to the turn-off IGBT characteristic where the tailing-off of the collector current will create a short circuit with the next switch turn-on [4].

The main propose of this paper is to develop the new commutation technique which introduce the usage of several passive filter design into SPMC topology. A systematic switching sequence is required that lengthens the dead time between conduction of each IGBT's in SPMC to protect it from malfunction and damaged as a result of existence of voltage and current spike due to short circuit. The implementation of the filter in SPMC topology is to reduce the number of harmonic component at the SPMC output. Experimental simulation result with different type of filter design will be presented to verify the comparison between without filter and with filter.

II. THE SPMC

The single-phase matrix converter (SPMC) consists of a matrix of input and output lines with four bi-directional switches connecting the single-phase input to the single-phase output at the intersections. The ac-ac single-phase matrix converter is a power converter that is converts the ac input to the ac output with variable amplitude ant the different frequency. The ac-ac

single phase matrix converter can be illustrated schematically in Figure.

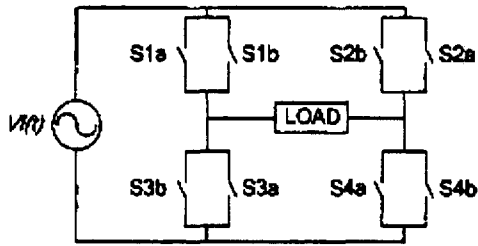

Figure 1 : SPMC circuit configuration

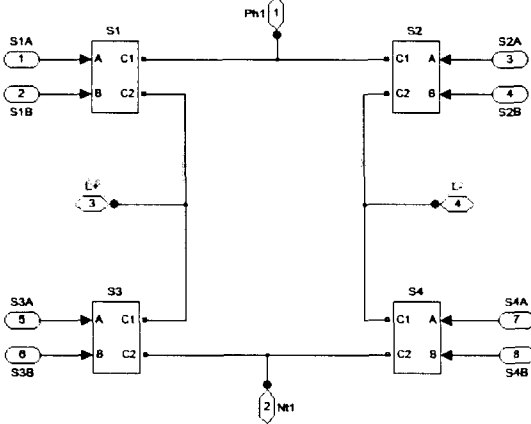

Figure 2 : SPMC circuit configuration using MATLAB simulink

III. SWITCHING STRATEGIES

The switching strategies used in these studies are based on implementation of SPWM. Power switches, comprising IGBTs in the SPMC circuit are controlled where the switching angles of the 4 bi-directional switches uses where 'a' and 'b' are representing drivers one and two respectively. The rules are then modified to incorporate the following new switching rules and are also tabulated in Table 1.

Table 1 : Switching strategies

Input Frequency	Output Frequency	Time Interval	State	Switch "ON"	Commutation Switch "ON"
50 Hz	50Hz	1	1	S1a & S4a	S2a
		2	2	S1b & S4b	S2b

When the supply voltage is positive the switch is in state 3. Here, S3b is the controlling

switch to synthesize the SPMW pattern, S1b and S2b are maintain as continuously ON during this cycle; S2b to complete the loop for SPMW return and acts in conjunction with S1b is turn OFF. Due to the nature of operation the commutation period has to extend over the dead-time period to allow for energy to dissipate and hence current reversal due to inductive load are eliminated. Similarly switching state 4 are used during negative cycle to produce the next half cycle. Implementation of those rules is best illustrated with Figure 3 for each switching state.

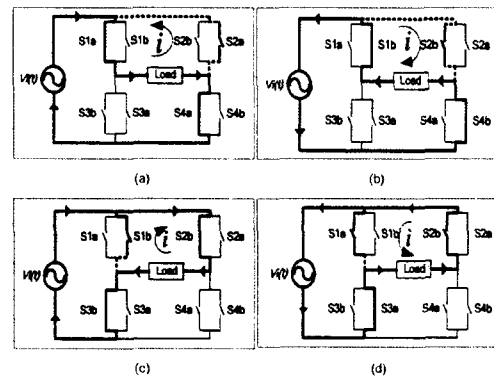

Figure 3 : Switching (a)state 1[positive cycle] (b)state 2 [negative cycle] (c)state 3 [positive cycle] (d)state 4 [negative cycle]

IV. THE SINUSOIDAL PULSE WIDTH MODULATION (SPMW)

The Sinusoidal Pulse Width Modulation (SPMW) is well known as wave shaping technique. For realization, a high frequency triangle carrier signal (Δ shape), V_c , is compared with a sinusoidal reference angle, V_r , as desired frequency. The output of SPMW is illustrated as Figure 4.

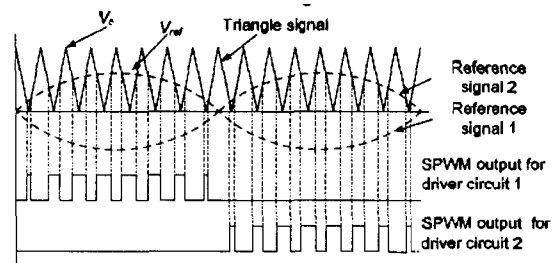

Figure 4 : Formation of SPMW

V. FILTER

There are many types of passive filter circuit which can be classified as variation of high-pass, low-pass and band pass. Low-pass filter will be use in this case study.

A low-pass filter only allows low frequency signal through its output. The pass-band of the low pass filter is below the cut off frequency and the stop band is above the cut off frequency. Figure 5 shows the schematic diagram of low-pass RL filter, RC filter and LC filter respectively.

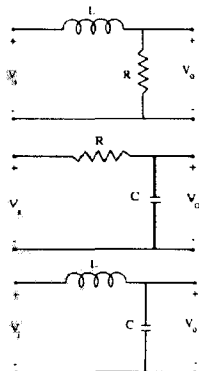

Figure 5 : Low-pass filter design

VI. COMPUTER MODEL AND SIMULATION SYSTEM

Figure 6 shows the overall circuit diagram of the AC chopper with filter by using MATLAB/simulink7.

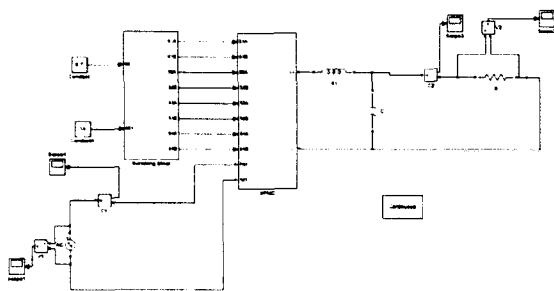

Figure 6 : Overall circuit diagram

Figure 7 shows the circuit diagram of switching block which is use to turn the SPMC as the AC chopper. The circuit diagram of the SPMC and switch are shown in Figure 8 and Figure 9 respectively.

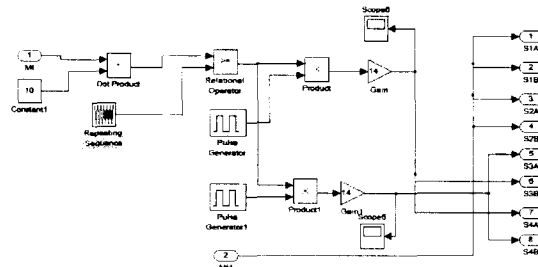

Figure 7 : Circuit diagram of switching block

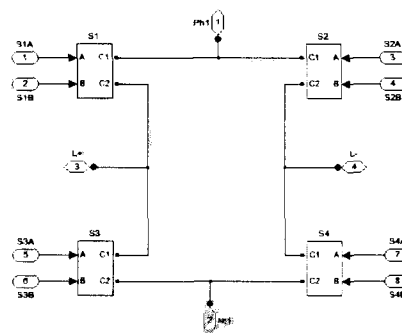

Figure 8 : Circuit diagram of SPMC by using MATLAB/Simulink7

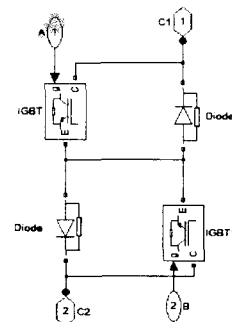

Figure 9 : Circuit diagram of switch by using MATLAB/Simulink7

The passive filter was installed at the output side to reduce the value of Total Harmonic Distortion (THD).

VII. RESULT

Simulation and experimental result of waveform synthesis of a SPMC are presented. Simulated input current and voltage waveform is shown in Figure 10 and Figure 11 respectively. Simulated

AC-AC SPMC waveform without safe commutation strategies is shown in Figure 12.

Table 2 : Parameters

Input source	50 V _{rms}
Reference frequency signal (f_r)	50 Hz
Modulation index	0.7
Load	100 Ω

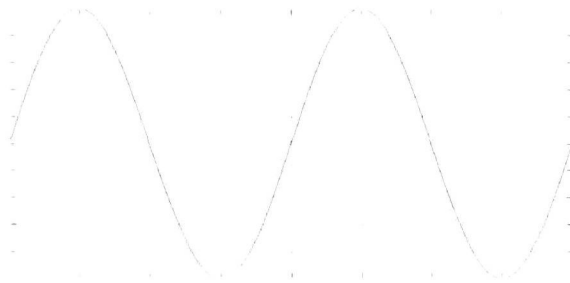

Figure 10 : Input voltage

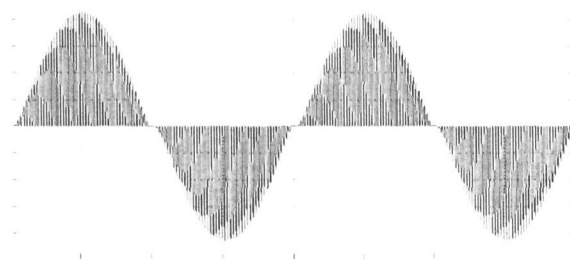

Figure 11 : Input current

Analysis without safe commutation

Simulated AC-AC SPMC without safe commutation is shown in Figure 12. It is shown that there is some voltage spike at the sinusoidal waveform at output voltage. At maximum frequency which 2000Hz, the value of total harmonic distortion (THD) is 6.53% as shown in Figure 13.

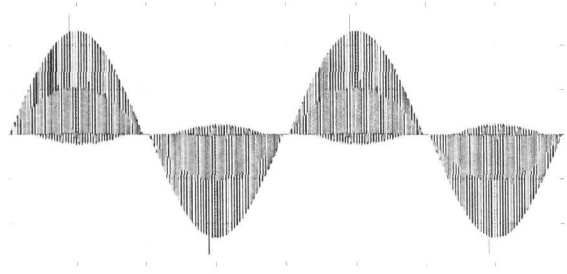

Figure 12 : Output voltage without filter

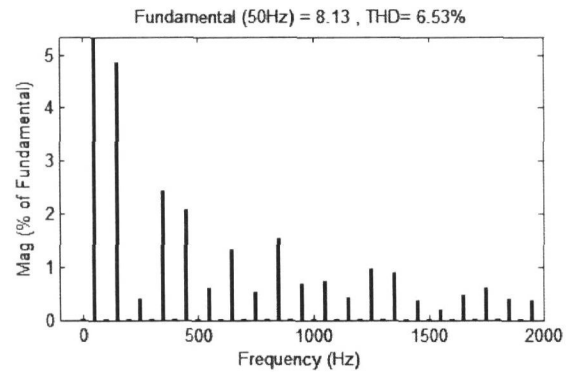

Figure 13: FFT analysis without safe commutation

The analysis was developed to reduce the voltage spike and reduce the value of total harmonic distortion (THD) by applying low-pass filter to the circuit. The analysis are shown as below with three different design of low-pass filter.

Safe commutation analysis with low-pass LC filter

Simulated AC-AC SPMC with safe commutation using LC filter design is shown in Figure 14. The waveform comes with proper sinusoidal. The SPMC was simulated and implemented based on parameters in Table 3.

Table 3 : Parameters for low-pass LC filter design

Inductance, L	5mH
Capacitance, C	1.267 μ F

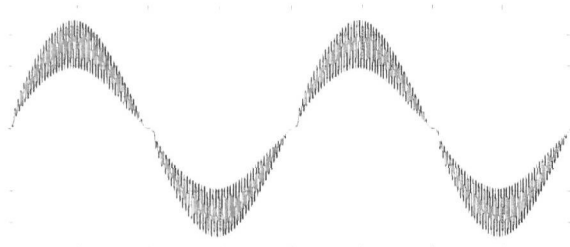

Figure 14 : Output voltage with LC filter design

At maximum frequency which 2000Hz, the value of total harmonic distortion (THD) for low-pass LC filter is 4.43% as shown in Figure 15.

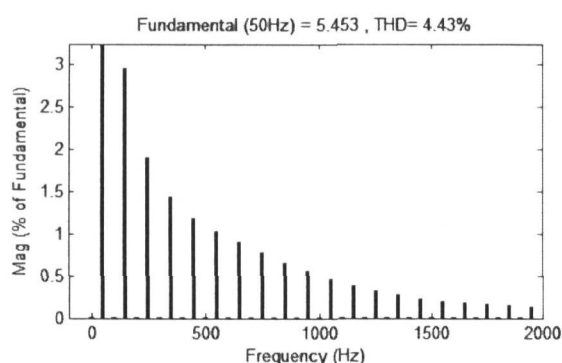

Figure 15 : FFT analysis for LC filter design

Safe commutation analysis with low-pass RC filter

Simulated AC-AC SPMC with safe commutation using RC filter design is shown in Figure 18. The waveform comes with some defects and not much different with analysis without safe commutation. The SPMC was simulated and implemented based on parameters in Table 5.

Table 4 : Paramaters for low-pass RC filter design

Resistance, R	50Ω
Capacitance, C	1.592μF

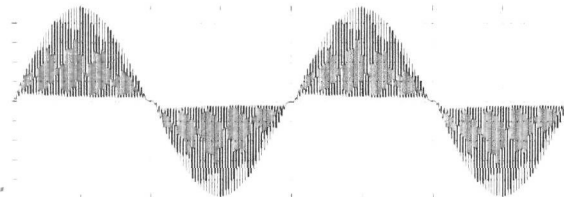

Figure 16 : Output voltage with RC filter design

At maximum frequency which 2000Hz, the value of total harmonic distortion (THD) for low-pass RC filter increase to 7.33% as shown in Figure 19 compare to the value without safe commutation.

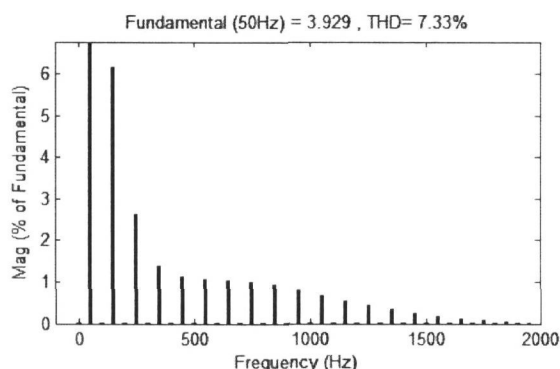

Figure 17 : FFT analysis for RC filter design

Analysis comparison

Analysis	THD (%)
Without filter	6.53
Low-pass LC filter	4.43
Low-pass RC filter	7.33

VIII. CONCLUSION

This paper has outlined and illustrated simulation model of an AC-AC SPMC using SPMW technique. Different type of filter design was implemented to avoid voltage spike. By adding passive filter into the circuit can improve the quality of output voltage. From the result obtained, the value of total harmonic distortion (THD) for analysis without commutation is 6.53%. By using low-pass LC filter design, the observation is getting better sinusoidal waveform and the value of THD is reduced to 4.43%. In the other side, the waveform by using

low-pass RC filter has some defect and the value of THD increased compare to without safe commutation which the value is 7.33%. As the conclusion, low-pass LC filter design is the feasible design in order to avoid voltage spike and reduce the value of THD for this case study.

In the future development, active filter also can be applied at the output of AC-AC SPMC. Future research may be needed in order to upgrade the SPMC by adding other algorithm either to control or to produce the complete filter design of SPMC.

IX. ACKNOWLEDGEMENT

Thanks to Allah who has given me the strength and ability to complete this paper. Gratefully acknowledgement to my project supervisor, Mrs Puteri Nor Ashikin bte Megat Yunus for the guidance and support throughout the development of this project. I would like to express my utmost gratitude to all who have been involved directly or indirectly.

X. REFERENCES

- [1] Saiful Firdaus; Mustafar Kamal Hamzah; "Modelling and Simulation of a Single-Phase AC-AC Matrix Converter Using SPWM", Universiti Teknologi Mara. Proceedings on Student Conference on Research and Development, (SCORED 2002), 16-17 July 2002, pp 286-289
- [2] Holmes D.G; Lipo T.A; "Implementation of a Controlled Rectifier Using AC-AC Matrix Converter Theory", University of Wisconsin-Madison
- [3] Zuckerberger, A. ; Weinstock, D. ; Alexandrovit, A., "Single Phase Matrix Converter", *IEEE Proc. Electric Power App*, Vol.144(4),Jul 1997 pp235-240
- [4] Zahiruddin Idris, Siti Zaliha Mohammad Noor & Mustafar Kamal Hamzah, "Safe Commutation Strategy in Single Phase Matrix Converter", IEEE Sixth International Conference PEDS 2005, Kuala Lumpur, Malaysia
- [5] Kwon, B.-H.; Min, B.-D.; Kim, J.-H.; "Novel Commutation Technique of AC-AC Converters", *Electric Power Application, IEE Proceedings-*, Volume: 145, Issue: 4, July 1998 Pages: 295-300.
- [6] Wheeler, P.W., Rodriguez, J., Clare, J.C., Empringham, L., Weinstein, A., "Matrix converters: a technology review," *IEEE Transactions on Industrial Electronics*, Vol. 49 (2), April 2002, pp. 276 – 28
- [7] Zahiruddin Idris, Mustafar Kamal Hamzah & Ahmad Maliki Omar "Implementation of Single-Phase Matrix Converter as a Direct AC-AC Converter Synthesized Using Sinusoidal Pulse Width Modulation with Passive Load Condition", IEEE Sixth International Conference PEDS 2005, Kuala Lumpur, Malaysia
- [8] Abdollah Koei & Subbaraya Yuvarajan, "Single-Phase AC-AC Converter Using Power Mosfet's," *IEEE Transaction on Industrial Electronics*, Vol. 35, No.3, August 1988 pp442-443
- [9] Cho, J.G., and Cho, G.H, "Soft-switched Matrix Converter for High Frequency direct AC-to-AC Power Conversion," *Int. J. Electron.*, 1992, 72,(4), pp. 669-680.
- [10] Oyama, J., Higuchi, T., Yamada, E., Koga, T., and Lipo, T., "New Control Strategies for Matrix Converter," *IEEE Power Electron. Spec. Conf. Rec.*, 1989, pp. 360-367.
- [11] M. D. Singh and K. B. Khanchandani, "Power Electronics", Publisher: Tata McGraw-Hill Publishing Company Limited 1998
- [12] Buane Hanselman, Bruce Littlefield, 1996, Mastering MATLAB a Comprehensive Tutorial & References,

Prentice Hall, The MATLAB Curriculum Series, New Jersey.

- [13] Hosseini, S. H.; Babaei, E, "A New Generalized Direct Matrix Converter", Industrial Electronics, 2001.