



DEPARTMENT OF BUILDING

FACULTY OF ARCHITECTURE, PLANNING, AND SURVEYING

UNIVERSITI TEKNOLOGI MARA

(PERAK)

THE CONSTRUCTION OF SOIL NAILING

PREPARED BY:

MUHAMMAD EIZZAM BIN MOHD ZIN

(2019807266)

DEPARTMENT OF BUILDING
FACULTY OF ARCHITECTURE, PLANNING AND SURVEYING
UNIVERSITI TEKNOLOGI MARA
(PERAK)

FEBRUARY 2022

It is recommended that the report of this practical training provided

By:

MUHAMMAD EIZZAM BIN MOHD ZIN

(2019807266)

THE CONTRUCTION OF SOIL NAILING

be accepted in partial fulfillment of requirement has for obtaining Diploma in Building.

Report Supervisor:

Ts Wan Nur Syazwani Binti Wan Mohammad

Practical Training Coordinator:

Dr. Nor Asma Hafizah Bt Hadzaman

Program Coordinator:

Dr. Dzulkarnaen Bin Ismail

DEPARTMENT OF BUILDING
FACULTY OF ARCHITECTURE, PLANNING, AND SURVEYING
UNIVERSITI TEKNOLOGI MARA
(PERAK)

FEBRUARY 2022

STUDENT'S DECLARATION

I hereby declare that this report is my own work, except for extract and summaries for which the original references stated herein, prepared during a practical training session that I underwent at Geostrength Engineering Sdn. Bhd. for duration of 17 weeks starting from 13 September 2021 and ended on 10 January 2022. It is submitted as one of the prerequisite requirements of BGN310 and accepted as a partial fulfillment of the requirements for obtaining the Diploma in Building.

.....

Name: MUHAMMAD EIZZAM BIN MOHD ZIN

UiTM ID No: 2019807266

Date: 10 JANUARY 2022

ACKNOWLEDGEMENT

Alhamdulillah, praise to Allah, the Most Merciful, the Most Graceful. I would like to extend my heartfelt gratitude for the guidance, advice and help rendered throughout the period of training by the following group of amazing individuals. First and foremost, I would like to thank Mr. Alif Aiman bin Dato Amran as a site engineer for the opportunity given, to conduct my training in his esteem company. His team of professionals comprising of En Izwad Idha as a site supervisor and En Mohamad Ikram as a stie safety supervisor, have enabled me to learn and develop my understanding, knowledge and feel of real time projects, and the theory involved in analysis of structures, slope and civil works. They are also responsible towards streamlining and assessing my training. It is an honor for me to be given the opportunity to ‘work’ with all of you.

I would also like to thank **ALL** the UiTM lecturers that have taught and nurtured me in becoming a better student and person. I would also like to extend my deepest appreciation to the lecturers who are directly involved during my training stint. To Ts Wan Nur Syazwani binti Wan Mohammad, Supervising Lecturer, En. Muhammad Naim Bin. Mahyuddin as an evaluation lecturer, Miss Azizah Bt Talkis and Dr Nor Asma Hafizah Bt Hadzaman as a practical training coordinator and Dr. Dzulkarnaean Bin Ismail, Program Coordinator. I value the time, effort, encouragement and ideas that they have contributed towards the successful completion of my training, this report and the valuable knowledge that have been shared over the last few semesters. Last but not least, my special thanks to my beloved parents for their sacrifices over the years. Thank you.

ABSTRACT

Soil nailing is a remedial construction measure to treat unstable natural soil slopes or as a construction technique that allows the safe over-steepening of new or existing soil slopes. This construction is to avoid the soil slopes from collapse. However, currently there is limited research conducted on proper construction of soil nailing. Therefore, this report will discuss about soil nailing and grid beam construction at repairing slope at SMK Desa Petaling, Jalan 3/125, Taman Desa Petaling, 57100 Kuala Lumpur, Wilayah Persekutuan Kuala Lumpur.

The objective of this report is to determine the construction of soil nailing and the method how to carry out. It will focus on the whole process starts from site clearance until construct nail head. In addition, the soil nailing construction has approximately 7 steps to follow starting from site clearance, setting out process, drilling, inserting steel bar, fill grout and pull-out test. It is also to investigate about the machinery and equipment that be used in soil nailing such as portable drilling rig, air compressor, control panel, power pack, grout mixer and others. This report is also to discuss about the problem that has been faced during the project such as the slope surface was collapse and the soil containing a hard rock. This report also to figure out the best solution to handle the problem and how to avoid that obstacle from repeat again.

As conclusion, soil nailing construction is very important to prevent the landslide especially to an area who has high risk such as residential area at the hillside and so on. Thus, by knowing the proper soil nailing methods it can help the contractors in other to strengthen their knowledge in soil nailing construction for the future.

CONTENTS	PAGE NO
Acknowledgements	1
Abstract	2
Contents	3
List of Tables	4
List of Figures	5
CHAPTER 1.0 INTRODUCTION	
1.1 Background of Study	6
1.2 Objectives	8
1.3 Scope of Study	8
1.4 Methods of Study	9
CHAPTER 2.0 COMPANY BACKGROUND	
2.1 Introduction of Company	11
2.2 Company Profile	13
2.3 Organization Chart	14
2.4 List of Project	15
2.4.1 Completed Projects	15
2.4.2 Project in Progress	16
CHAPTER 3.0 CASE STUDY	
3.1 Introduction to Case Study	17
3.2 Methods of soil nailing	19
3.3 Problems and solutions	26
CHAPTER 4.0 CONCLUSION	
4.1 Conclusion	27
REFERENCES	28

LIST OF TABLES

Table 2.4.1	List of Completed Projects	15
Table 2.4.2	List of Progress Projects	16

LIST OF FIGURES

Figure 2.1. Logo of Company	11
Figure 2.2. logo of company	13
Figure 2.3 Photo of company organization chart	14
Figure 3.1.1 Photo of site plan	17
Figure 3.1.2 Photo of site barrier	18
Figure 3.2.1 Photo of site clearance	19
Figure 3.2.2 Photo of setting out	19
Figure 3.2.3.1 Photo of drilling process	20
Figure 3.2.3.2 Photo of Drilling process	20
Figure 3.2.4.1 Photo of steel bar installation	21
Figure 3.2.4.2 Photo of detail about soil nail	22
Figure 3.2.5 Photo of Grouting process	22
Figure 3.2.6 Photo of Pullout test	23
Figure 3.2.7.1 Photo of reinforcement work	23
Figure 3.2.7.2 Photo of installing steel plate for nail head	23
Figure 3.2.8 Photo of installation formwork for grid beam	24
Figure 3.2.9 Photo of concreting grid beam	24
Figure 3.2.10.1 Photo of construction of nail head	25
Figure 3.2.10.2 Photo of nail head and grid beam	25

CHAPTER 1.0

INTRODUCTION

1.1 Background of Study

The title of this report is about soil nailing. Soil nailing is a method that has been used for repairing slope to protect the slope from collapse and prevent landslide. Soil nailing is a remedial construction measure to treat unstable natural soil slopes or as a construction technique that allows the safe over-steepening of new or existing soil slopes. The technique involves the insertion of relatively slender reinforcing elements into the slope – often general-purpose reinforcing bar or rebar although proprietary solid or hollow-system bars are also available. Solid bars are usually installed into pre-drilled holes and then grouted into place using a separate grout line, whereas hollow bars may be drilled and grouted simultaneously by the use of a sacrificial drill bit and by pumping grout down the hollow bar as drilling progresses. Kinetic methods of firing relatively short bars into soil slopes have also been developed.

Soil nailing is important for the slope because it can hold the soil from collapse especially for an area near the residential area. This construction will prevent an accident that can cause the loss for the country and also the people. The first step of soil nailing is doing site clearance and then doing setting out process to marked the placed or point that will be drill. After that, the drilling process can be start and drill the soil to make a hole following the depth that has been stated on the contract. The steel rebar will be insert in the hole after the drilling process and then will be filled with grout. Next, after the grout are reach the maturity ages which is 28 days, pull out test need to be done to test either the nailing can accommodate the load that has been plan or not. The finishing of the soil nailing process has a few types such as grid beam and guniting. In this report, the grid beam finishing has been chosen to make it looks beautiful and tidy, it is because this project is located at the school and it can make the school looks more greenish and cheerful.

The types of finishing can be chose based on the location of the project. The guniting or shortcrete process is simpler than grid beam and the cost also cheaper but the cosmetic value of

the guniting process is lower than grid beam. So, the guniting process is more suitable for the project at the mountain or the hill.

Thus, the aims of study are to observe the methods that has been used in soil nailing construction and to learn about the slope remedial. Other than that, this study also to determine the time and cost to construct a soil nailing and the problems that usually be faced during the construction.

1.2 Objectives

- i. To determine the methods of soil nailing construction

- ii. To investigate the problems occurred and solutions taken to solve the problems

1.3 Scope of Study

The scope of study was carried out at SMK Desa Petaling, Jalan 3/125, Taman Desa Petaling, 57100 Kuala Lumpur, Wilayah Persekutuan Kuala Lumpur. The project was started on 1st of July 2021 and the completion date is on 21st of May 2022. This project cost for over 1 million Ringgit Malaysia which is RM 1,573,305.00. This project is currently on going. Therefore, the focus of study is to investigate the methods of soil nailing construction. Hence, this project containing 569nos of soil nailing and 1253nos of grid beam. During this period, it is an opportunity to see the method that has been used to prevent landslide. Furthermore, the problems and the solution also include in this study. Even so, the study did not concentrate on the quantity of manpower or labors and the duration matters. In order to fulfill the data, there were three methods need to be carried out which is observation, interview, and document reviews. In conclusion, all further explanation relating the above methods were explained as below.

1.4 Methods of Study

1.4.1 Observation

The observation is a way of collecting data through observing. The observation is about how the soil nailing construction process starting from the drilling process until filled with grout. The average time taken for the process is an approximately around 1 hour per one point but this period also depends on the type of soil of the slope which is if the soil is compact and hard it will take more time for the drilling process. Meanwhile, for the finishes which is grid beam and nail head it will take around a week because this project is use cast in-situ grid beam. So, there are a few processes need to be done before the concreting process can be start which is we have to install the reinforcement bar on one point to another point and then install formwork following to the drawing plan. After that, the formwork has to be checked by client to make sure that an alignment is straight. Then, the concreting process can be proceed and it will take 3 days to dismantle formwork. If the concrete has a defect, the rectification work should be taken as soon as possible.

1.4.2 Interview

The interview is one of the methods to collect the construction data by doing the structured or semi structured interview with the responsibility person for the project. The interview can be carried out while doing an observation and while doing the work at the site. The interview was conducted with the company manager, the contractor who is responsible for handling the project on the construction site. This interview was also done to the workers who were at the construction site while doing soil nailing process. Semi-structured interviews were also conducted with the contractor responsible for conducting the project each week in the office and usually carried out around 10 – 15 minutes. The semi-structured interview recorded through short notes.

1.4.3 Document Review

The document review is the method that has been used to get the data about soil nailing process which is from the drawing plan, progress report, site diary, and also from the Bills of quantity document of the project. The data will be noted and be combined and put it in the note book for the review in the future.

CHAPTER 2.0

COMPANY BACKGROUND

2.1 INTRODUCTION OF COMPANY



Figure 2.1.1 logo of company

Source: geostrength engineering sdn. Bhd. 2021

GEOSTRENGTH ENGINEERING SDN BHD is a company that was founded in September 1997 by Dato Hj Amran Mohamad, Hj Khairul Azam Zahidi, and Ir. Sir Hj. Hamdan Sopian. The company is registered under Companies Commission of Malaysia (SSM) with a paid-up capital of RM 3,000,000.00. This company is expertise in geotechnical and civil engineering was one of the key factors that began the contract with the Public Works Department (JKR) as early as 1999, in relation to the evaluation of work performance, **GESB** is listed among the permanent contractors in the construction and repair sector for agencies such as Bekalan Air Selangor, TNB, PLUS, UEM ministries and private institutions and even local authorities. Geostrength Engineering sdn bhd 2021.

Having been in the engineering industry specializing in geotechnical for more than 20 years has opened up **GESB**'s potential to expand the scope of existing projects with the upgrading to CIDB to G7 grade and ISO 9001:2015 quality certification by regulatory bodies that enable **GESB** to carry out construction scopes in a more mega-direction. UEM's award-winning 2017 Bumiputera Contractor Award as well as JKR Malaysia's excellent 2018 Contractor Empowerment Award 2017 by UEM and the JKR Malaysia Excellent 2018 Contractor Award have put **GESB** at a higher level in terms of producing quality work. Geostrength Engineering sdn bhd 2021.

As a step towards enhancing the company's performance and capabilities, **GESB** has taken the initiative by opening a highly-trained training center since 2017 in the past to help the contractors from G1 to G7 acquire certain basic skills sets under geotechnical aspects. It is expected that **GEOSTRENGTH ENGINEERING SDN BHD** will remain outstandingly competitive and strive for excellence in the upcoming future in line with the company's stated vision and mission. Geostrength Engineering sdn bhd 2021.

2.2 COMPANY PROFILE



Figure 2.1.1 logo of company

Source: geostrength engineering sdn. Bhd. 2021

NAME : GEOSTRENGTH ENGINEERING SDN BHD

REGN. NUMBER : 1997001030782 (446281-T)

ADDRESS : No. 34-5-1, Jalan 2/101C, Batu 5, Jln Cheras, Cheras Business Centre,
56100 Cheras

MISSION : “To provide efficient services, quality and productive for client”

VISION : To be one of the top specialists in geotechnical engineering in the global
arena

(Source: Geostrength Engineering sdn bhd 2021)

2.3 company organization chart

CARTA ORGANISASI

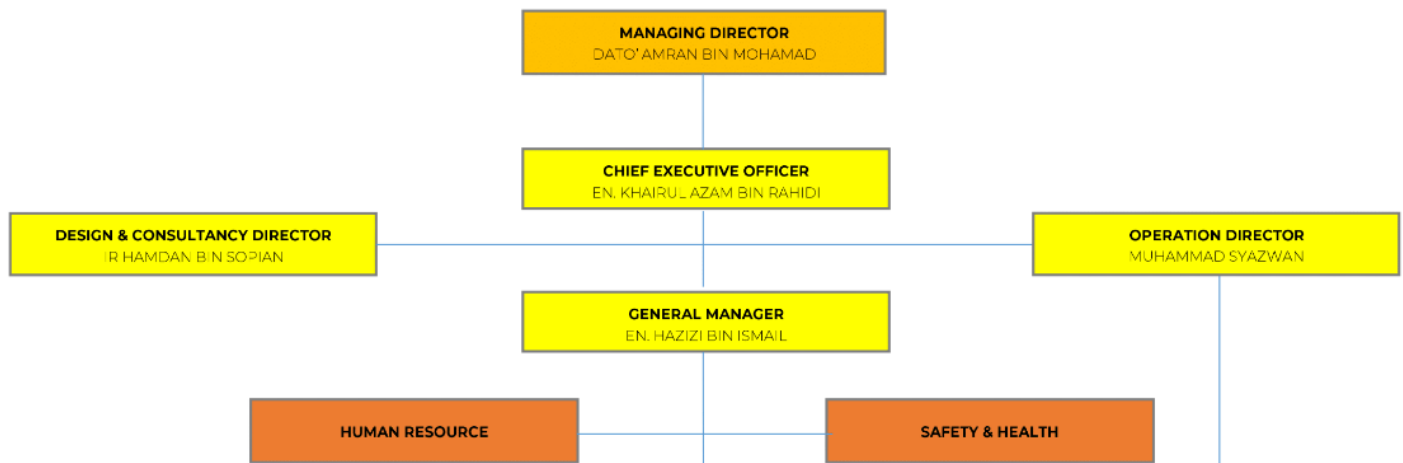

Figure: 2.3 organization chart

(Source: Geostrength Engineering sdn bhd 2021)

2.4 List of projects

On the table 2.4.1 there are a few completed projects that has been carried out by Geostrength Engineering Sdn Bhd on the last few years. Other than that, on the table 2.4.2 there are four projects who are in the progress.

2.4.1 completed project

N O	PROJECT TITLE	SCOPE OF WORK	CONTRACT VALUE	DURATION	CLIENT
1	Kerja-kerja pembaikan mendapan tanah bagi grid maintenance (Selangor), grid maintenance, bahagian grid TNB-pakej A-PMU Pandamaran	Micropile	RM1,141,720	16/10/2020-13/2/2021	Temavista Sdn Bhd
2	Pakej B: cadangan kerja pembaikan cerun di menara no.9 SGRI-BGJH,Lumut, perak bagi Jabatan Grid Maintenance bahagian Grid TNB	-soil nailing -guniting work -horizontal drain -hydroseeding	RM687,300	3/12/2019-31/5/2020	TNB
3	NKEA 'greater kuala lumpur klang valley' River Of Life (ROL) kerja pembaikan struktur sungai sepanjang 10.7m sg. klang – sg. Gombak	-micropile -ground anchor -grouting	RM8,425,870	28/6/2018-20/1/2019	HCH-Engineering Sdn Bhd
4	Kerja-kerja pembaikan cerun menggunakan kaedah reprofile, hydroseeding, soil nailing dang uniting di laluan A006, seksyen5.90 CR, Jalan sumpitan-ijok, hulu Perak, Perak.	-earthwork -soil nailing -drainage -guniting -hydroseeding	RM1,076,543	10/4/2019-24/7/2019	Pintas Utama Sdn Bhd

Table 2.4.1 list of completed project Geostrength Engineering sdn bhd 2021

2.4.2 project in progress

NO	PROJECT TITLE	SCOPE OF WORK	CONTRACT VALUE	DURATION	CLIENT
1	Kerja pembaikan cerun (tower foundation stabilizer) di Grid Maintenance South (Subzone Kluang), bahagian grid TNB, pakej C-TN58-132Kv KLID-MSNG	-Excavation -soil nailing - hydroseeding -guniting -drainage	RM497,545	On going	TNB
2	Cadangan pindaan dan tambahan bangunan stesen atas 1 tingkat sediaada kepada 2 tingkat, di atas lot 250, Bandar bukit bendera, daerah timur laut, Pulau Pinang	Micropile	RM1,070,225	On going	Persada Satria (M) Sdn Bhd
3	Projek pembaikan cerun dan kerja-kerja berkaitan di SMK Desa Petaling, Kuala Lumpur.	-backfilling -soil nailing -grid beam -close turfing -drainage	RM1,573,305	On going	KI Engineering Sdn Bhd
4	Projek kerja-kerja pembaikan cerun runtuh fasa 1 dan fasa 2 di Istana Negara, Kuala Lumpur.	-Excavation and filling -buttress wall -micropile -soil nailing -drainage	RM2,197,185	On going	KI Engineering Sdn Bhd

Table 2.4.2 list of projects in progress, Geostrength Engineering sdn bhd 2021

CHAPTER 3

CASE STUDY

3.1 INTRODUCTION TO CASE STUDY

The case study is about the soil nailing construction to repair the slope at SMK Desa Petaling, jalan 3/125, Taman Desa Petaling, Kuala Lumpur, 57100 Wilayah Persekutuan Kuala Lumpur. This project was started 1st of July 2021 and will be completed on 21st of May 2022. The cost of this project is RM 1,573,305.00. Currently, this project is still on progress. Thus, the study will be explained not only regarding installation but including the machinery and tools, the time that have been carry out and the problem and solution of the construction.

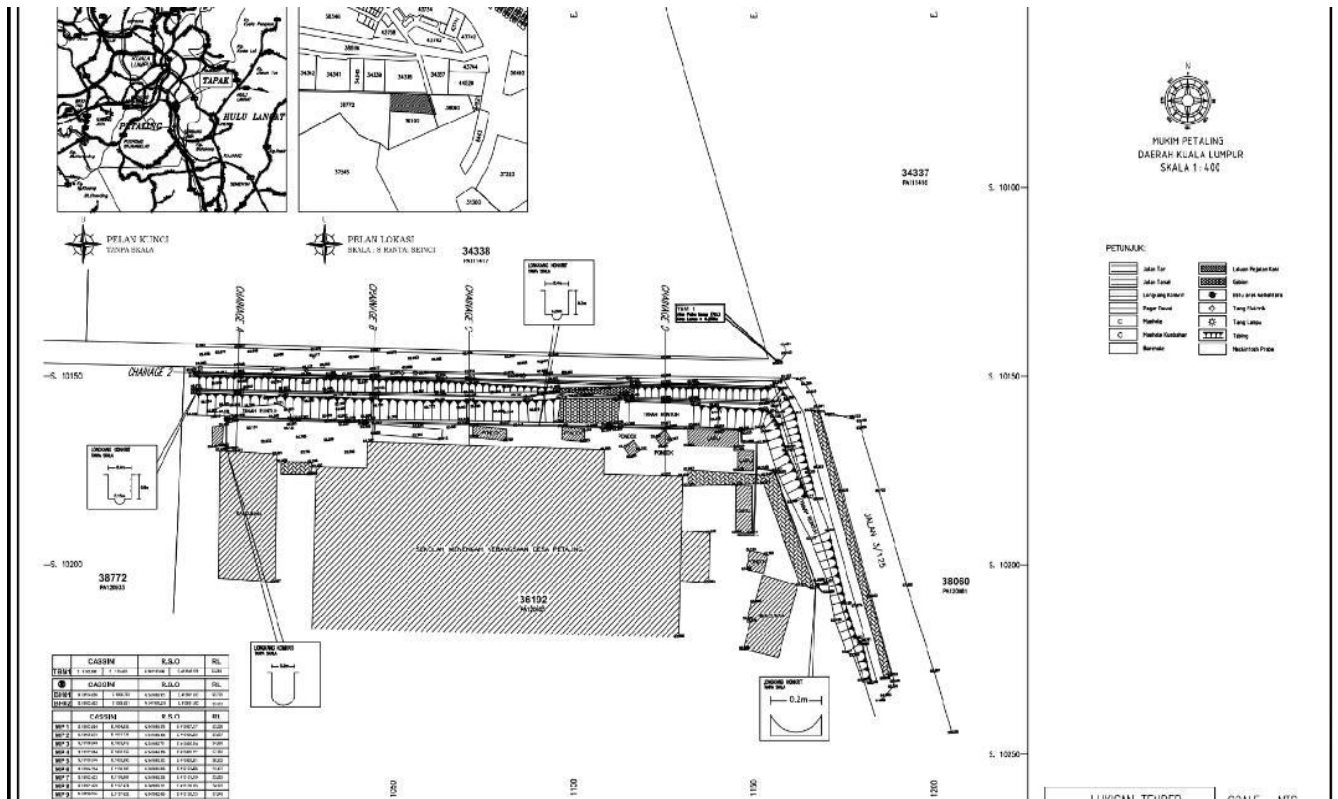

Site plan (figure 3.1.1)

The location of the project is located inside the school area. So, the safety of the student should be taken seriously to avoid an incident who involve the students. The site area was covered by hence and barrier to prevent the student from entering the site area.



Site covered by barrier (figure 3.1.2)

The activities that have been carried out on the site is soil nailing construction. This work should be taken by the contractors that have an experience and skill workers. It is because it needs to use some kinds of specialist machine such as portable drilling rig, Air Compressor ,Control Panel (used to contol the drilling rig during drilling process), Power Pack, Mechanical Grout Mixer, Air Hose, Hydraulic Hose, Welden Pump and Sprilit Level to Measure the inclination of borehole.

Next, the time is very important for the success of the construction. By referring the drawing plan, the area of the slope is around 2160m² and has 569nos of soil nailing. It has been divided into 4 section which is Section A, B, C, and D. It also has a two steps of the slope upper slope and below slope. Before the drilling process the point of the nailing need to be marked first to avoid an error during the drilling process. The length of each nailing point is approximately 1.5 to 1.7 meters.

3.2 METHODS OF SOIL NAILING

3.2.1 Site clearance



Figure 3.2.1 workers cutting the tree

First, site clearance is important to make sure that the site was tidy and did not have an obstacle such as the trees that can disturbing the progress of work in the future. During site clearance, the supervisor need make sure that the area that will be use is clear and safe to work. For this process, it was took time around two weeks and the cost approximately RM10,000.00.

3.2.2 Setting out



Figure 3.2.2 workers doing setting out

Setting out process is to determine the point of nailing and will be marked to make sure that the alignment and length of each point are following the plan. This process usually will be finished in around 3 days. There are a few benefits for doing this process such as it will help the workers to work more efficient and faster and it will avoid the soil nailing point will scattered.

3.2.3 drilling



Figure 3.2.3.1 installing scaffold

Before the drilling process can be start, the staging should be installed as a platform for the portable drilling rig and for the workers to walk during the process. Installing scaffolding is a complicated process because it has a lot of components to be connect and tighten. This process will take around 1-2 days. The scaffold should be examined by scaffolder before it can be approved to use.



Figure 3.2.3.2 drilling process

The drilling process can be start following the marking point that has been pointed. The depth of the hole is 9m following the plan that has been given by the client. This drilling process will take approximately 30 to 40 minutes per points. However, there is a few points who take more time because the soil was hard and containing the rock.

3.2.4 Steel bar installation



Figure 3.2.4.1 steel bar who has been installed

The steel bar which is T25 bar was holstered with corrugated and centralizer (figure 3.2.4.2) before it will insert into the hole, this method is to prevent the bar from rusty for a short term. This process will take only a few minutes because the procedure is not involved with any machines. The prices for the soil nailing process is approximately RM850.00 for each and the total of the soil nailing is 569nos.

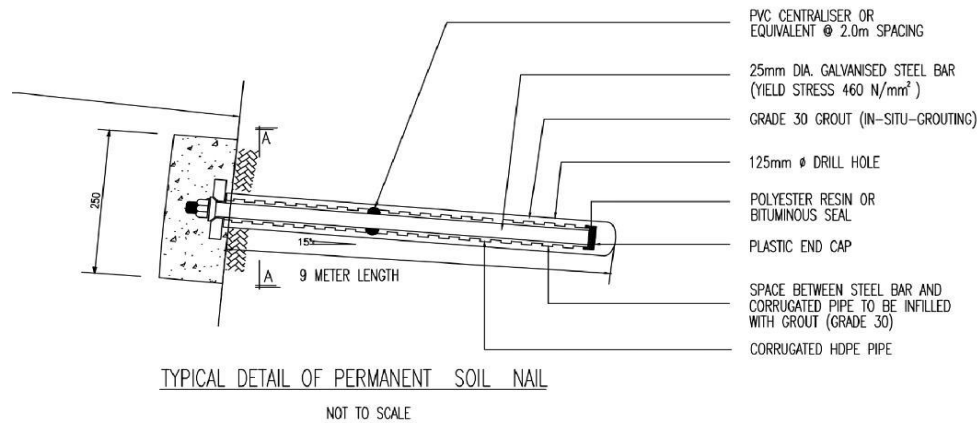

Figure 3.2.4.2 detail drawing about soil nailing

3.2.5 Grouting process



Figure 3.2.5 grouting process

Grouting is the process to fill the hole that has been drill. The grouting process is important in soil nailing construction because it function to holding the nailing into the ground to make sure that nailing can accommodate with the load that has been set for each nailing. This process usually takes 5-10 minutes per point. The machinery that been used for this process is air compressor, grout mixer, and others.

3.2.6 Pull-out test



Figure 3.2.6 pullout test

Pull-out tests are typically performed to assess the anchorage or pull-out capacity of geosynthetics. This capacity is important in situations such as retaining walls, slopes and bridging over voids, where the geosynthetic is anchored into stable ground that is outside the zone of failure. The test can also be used to assess interface shear resistance and stiffness properties for applications where soil is moving relative to the geosynthetic. Pull out test can be done after the maturity ages of the grout which is 28days after the grouting process. This test is important because it can prove that the nailing is following the specification that has been state on the plan such as the length of the steel bar and so on. If the length did not follow the specification so the test will be failed and a new nailing should be insert again.

3.2.7 Reinforcement work



Figure 3.2.7.1 reinforcement work



figure 3.2.7.2 install steel plate

Reinforcement work is a process for construct grid beam. The reinforcement bar should be installed to connect from one point to another point. The preparation for this process will take around 3-4 days and then the installing process will take around 2-3 days. Then, the installation of steel plate for nail head will be continue before installing the formwork (figure 3.2.7.2).

3.2.8 Installation of formwork for grid beam



Figure 3.2.8 install formwork

The formwork for grid beam will be installed after the reinforcement work have done. It is because the formwork needs to follow the alignment of the reinforcement bar. The space of the formwork should be 150mm to make sure that the size of the grid beam is similar to each other and followed the drawing plan. Formwork is one of the challenging parts in soil nailing construction because it functioning as a mold for concrete, if it was installed tilted the final product will be tilted too and the clients will unsatisfied. The formwork can be installed 20nos per day.

3.2.9 Concreting of grid beam



Figure 3.2.9 concreting work

For grid beam, the grade of concrete that has been use is G25 with the ratio 1:1.5:3. During the concreting process, a concrete vibrator machine was being used to compact the concrete to avoid the defect after dismantle formwork. For each grid beam it will cost approximately RM220.00 and the total of grid beam is 1253nos.

3.2.10 Construction of nail head



Figure 3.2.10.1 construct nail head

For the nail head, the mold will to be made following the size on the drawing plan which is 250mm x 250mm, then it will be installed at the grid beam after dismantle formwork and proceed for concrete. The grade of concrete for nail head is the same with the grid beam which is G25. Finally, after 3 days the formwork of nail head can be removed and will be like below (figure 3.2.10.2). this cap or nail head cost for each is approximately RM100 and the have the same numbers with the soil nailing number which is 569nos.



figure 3.2.10.2 nail head

3.3 PROBLEMS AND SOLUTIONS

It is a common thing when it comes to construction there will be a problem at the site during the construction process such as the insufficient material on site, un-skill workers, weather forecast and others. In this project, the problems that has been faced is about the workers did not follow the instruction from the supervisor and the lack of carpenter.

3.3.1 Workers did not follow the instruction

This problem happens because the foreign worker did not understand the language so there is miscommunication between the workers and the site supervisor. This problem will affect the plan progress that has been made for them which is they are not followed the schedule and doing what they think its suitable for them.

Due to this issue, the supervisor was making a mind map with easy to understand for the workers who did not understand the languages and was patch it at in front of site cabin. The workers who understand the mind maps need to explain to other workers using their languages so that the problems will not repeat it again.

3.3.2 Lack of carpenter

The carpenter is one of the high salary jobs, that is why the sub-contractor did not want to hired skill workers of carpenter to doing the job because it will affect their profit. The daily salary of one carpenter is same with 3 normal workers. The big issue of this problem was affected the progress because the concreting process of grid beam cannot be approved by a client. It is because the alignment of the form work was tilted.

This problem is a huge issue but there is a solution for this problem which is we are call the sub-contractor to discuss about the payment of the project again to make sure that the sub-contractor will agree with the payment and can hired the skill carpenter

CHAPTER 4

CONCLUSION

In conclusion, this report is explained about the soil nailing construction at SMK Desa Petaling, Taman Desa Petaling, Kuala Lumpur. The objective of this report is investigated the methods of soil nailing construction, to identify the time and cost of constructing soil nailing and also to determine the problems occurred and solution taken to solve the problems. This study was based on my own observation on site, document review such as drawing plan and bills of quantities and also an interview with site supervisor, Project manager and an engineer. From this report, it is explained on how to construct the soil nailing from the beginning until the project completed. This studies also describe about the time and the averages cost that needed to running the project. On the other hand, this report is also discussed about the problems and their best solution to overcome that problem to make sure that the issues did not repeat again. Through the soil nailing construction on site, it can be seen clearly and understanding the whole process to construct the soil nailing and grid beam and the best way to overcome the problems to make the last product will be tidy and satisfied for the client. I really hope that this report will help the others to understand about soil nailing and how to construct it with the true methods in the future.

REFERENCES

Web Site:

- <https://geostrength.com.my/>
- https://en.wikipedia.org/wiki/Soil_nailing
- <https://www.google.com/search?q=soil+nailing&oq=soil+nailing&aqs=chrome..69i57.2298j0j9&sourceid=chrome&ie=UTF-8>
- <https://www.sciencedirect.com/topics/engineering/pullout-test>
- <https://www.deepexcavation.com/en/products/snail-plus-soil-nailing-software/design-of-soil-nail-walls-information>
-