

## MICROCONTROLLER BASED WATER TANK MANAGEMENT MONITORING SYSTEM

\*Siti Aishah Che Kar, Nur Idawati Md Enzai, Ahmad Faidhi Mohd Hatim, Aqib Fawwaz Mohd Amidon, Ahmad Faris Firdaus Mohd Sapawi

Faculty of Electrical Engineering  
Universiti Teknologi MARA (UiTM) Terengganu  
23000 Dungun, Terengganu, Malaysia

\* Corresponding author's email: [sitia2500@tganu.uitm.edu.my](mailto:sitia2500@tganu.uitm.edu.my)

*Submission date: 15 July 2017      Accepted date: 30 Sept 2017      Published date: 30 Nov 2017*

### Abstract

The water quality and quantity monitoring system is designed to give an early warning detection of home water tank. The design of this project is based on ATmega328P microcontroller as the main controller for the whole system. The ultrasonic sensor and pH probe are used as inputs to the system. All the signal inputs from Ultrasonic sensor and pH probe will be transmitted to the microcontroller. The microcontroller will process the inputs and determine the consequence outputs. The 16 x 2 character LCD display, buzzer and the LEDs are used as outputs. The LCD will display the remaining water level in the tank and water quality continuously. The three LEDs are used as indicator in this project to indicate three stages of water level which are: high level, medium level or low level. Lastly, a buzzer is used as an alarm and will be activated when the water level is at the lowest level. Basically, this system is designed to aid home owners in monitoring supply and safety of water tap in their home.

**Keywords:** Microcontroller; Ultrasonic Sensor; pH Probe; LCD; Water tank;

### 1.0 INTRODUCTION

In our daily life, clean water supply is vital to us for daily needs such as drinking, washing, bathing and food preparation. The water tap must contain clean water that is free from any harmful germs and chemical for human consumption. Without the clean water supply, people will face many difficulties especially for domestic use. A research has identified one of the main factors which influence the health implications in the developing world that is inadequate clean water supply (Bartram & Cairncross, 2010).

Commonly, most of the home water tanks are located higher than ground to make sure the water supply chain is under high pressure. Thus, this condition indirectly makes it difficult for the user to check their water tank. The tank owner needs to climb up just for checking the condition of water level every time to ensure the water supply is in good condition or simply relying on water tank float system. Basically, most of the home water tanks are equipped with water tank float and valve to avoid the overflowed water. However there is no simple mechanism to detect if the water level is too low. Normally, they only assume the quality of water is in good condition until they found something odd or there is a foul smell. Thus, this project can make sure that these two main difficulties can be solved as well as reducing tedious work.

The main objective of designing this water quality and quantity monitoring system is to give an early warning detection of home water tank. The ATmega328P microcontroller is used as the main controller for the whole system. The ultrasonic sensor and pH probe are used as inputs to the system. All the signal inputs from Ultrasonic sensor and pH probe will be transmitted to the main controller. The microcontroller will process the inputs signal and determine the consequent outputs. The outputs of this system are LCD 16 x 2 character LCD display, buzzer and LEDs. The LCD will display the remaining water level and also water quality in the tank continuously. The three LEDs are used as indicator in this project to indicate three stages of water level namely high level, medium level and low level. A buzzer is used as an alarm and will be activated when the water level is at the lowest level. This will alert the consumers to be well prepared in advance. Generally, the benefit of this project is to make sure the safety and water level in the reserve tank can be continuously monitored.

### 1.1 Objectives of the Study

The main objective of this project is to design a system that will help to manage the domestic water tank more efficiently. Specifically the project's objectives are:

1. To measure the level of water in the tank by using ultrasonic sensor.
2. To measure the water pH value in the tank by using pH sensor.
3. To display water level using LCD with alarm warning system.

### 1.2 Scope and Delimitation of the Study

The project is focused on designing a microcontroller-based system for monitoring water quantity and quality. The scope of this project is mainly for domestic storage water tank. The main objective of this project is to measure the quantity of water level and the quality of water in the storage tank that is used in residential houses nowadays. This project is set to measure quantity of water only by three levels which are maximum level, half level and minimum level. Next, for the quality of water, the project only focuses on water pH sensing by using pH probe to measure the water pH value.

## 2.0 LITERATURE REVIEW

The uncontaminated water supply is vital for our good health and domestic use (Hunter et al., 2010). It is important to make sure the water comes from a domestic water tank which is safe for consumption. The consumers have to make sure the water supply is safe and minimize the risk of waterborne diseases from contaminated tank water. Water contamination can cause dangerous illness such as diarrhea which can be particularly dangerous for infants and people with very low immune systems.

The normal range for pH in water supply is 6.5 up to 8.5. Thus, water with pH less than 7 is considered acidic while water with pH more than 7 is considered alkaline. The measurement of alkalinity and pH is needed to determine the corrosivity of the water (Oram, 2015). There are possibilities when the water gets exposed to the carbon dioxide in the atmosphere; the pH value is changed to 5.2. This is due to association of pH with atmospheric gasses and heat; therefore it is strongly recommended that the water be tested as soon as possible (Harris & Tech, 2016).

Water with low pH value less than 6.5 could be acidic or corrosive water could be caused by leaking heavy metal ions such as iron, copper, lead, and zinc from the old plumbing and piping systems. Therefore, water with low pH could contain contaminated metals which will affect human health. Furthermore it also can cause damages to the mechanical and metal piping system (Pahlen, 2015). Meanwhile the water with pH reading higher than 8.5 could indicate that the water is alkaline. Even

though the alkaline water does not pose any health risk, this situation can lead into aesthetic problems such as precipitate on piping, can affect the water pressures, decreases the diameter of piping and reduces the effectiveness of washing (Oram, 2015).

Therefore, to address these two main difficulties, the water quality and quantity monitoring system is designed to give an early warning detection of home water tank. The design of this project is based on ATmega328P as the main controller in the system. The microcontroller has been selected in this project because it offers a lot of benefits such as low cost, simple design and ease of modification for battery-powered operation (Fisher & Sui, 2013).

An ultrasonic sensor and pH probe are used as inputs to the system. The ultrasonic sensor operates by transmitting ultrasonic signals towards an object and returns an echo reflection after impacting the object. The elapsed time between pulse transmission and echo time are correlated to the distance between these two objects. Fisher and Sui (2013) developed a system using the ultrasonic sensing for monitoring the water level in evaporation pans for irrigation setting. Kuantama et al. (2012) also employed ultrasonic sensors to measure water level in their early flood alerts system.

All the signal inputs from Ultrasonic sensor and pH probe will be transmitted to the microcontroller. The microcontroller will process the inputs and determine the resulted outputs. The LCD char 16 x 2 display, buzzer and the LEDs are used as outputs. The LCD will display the remaining water level and also water quality in the tank continuously. The three LEDs are used as indicator in this project to indicate three stages of water level namely: high level, medium level and low level. Lastly, a buzzer acts as an alarm and will be activated when the water level is at the lowest level.

### 3.0 METHODOLOGY

#### 3.1 Hardware Architecture and Implementation

The main components that make up this system are a microcontroller, ultrasonic sensor and pH probes. The other components that are also used are: Liquid Crystal Display (LCD) 16x2 char, a buzzer and three Light Emitting Diodes (LEDs). In this project ATmega328P is used as main core controller. The microcontroller is a high-performance Atmel 8-bit AVR RISC with 32KB flash memory, 1024B EEPROM and 23 general purpose Input/Output lines. It also has 32 general purpose working registers, three flexible timer/counters, byte-oriented 2-wire serial interface, serial port and a 6-channel 10-bit A/D (Bharani et al., 2014).

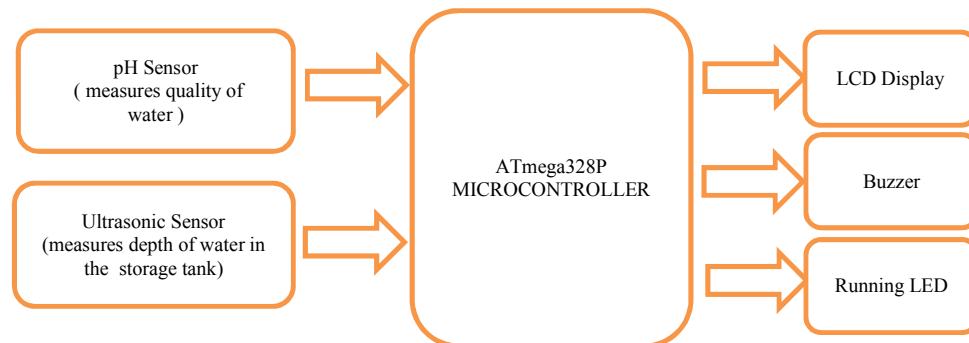

Figure 1 Block diagram of water quality and quantity monitoring based on Atmega328p microcontroller

### 3.2 Flowchart of Water Level Detection Using Ultrasonic Sensor

Figure 2 shows the flowchart of water level detection using ultrasonic sensor. The ultrasonic sensor will continuously monitor the water level in the tank by sending the ultrasonic signals. Then, the input signals will be transmitted to the microcontroller to process the data and provide the subsequent steps. The LCD will display different status according to the current water level status in the tanks as shown in Figure 2.

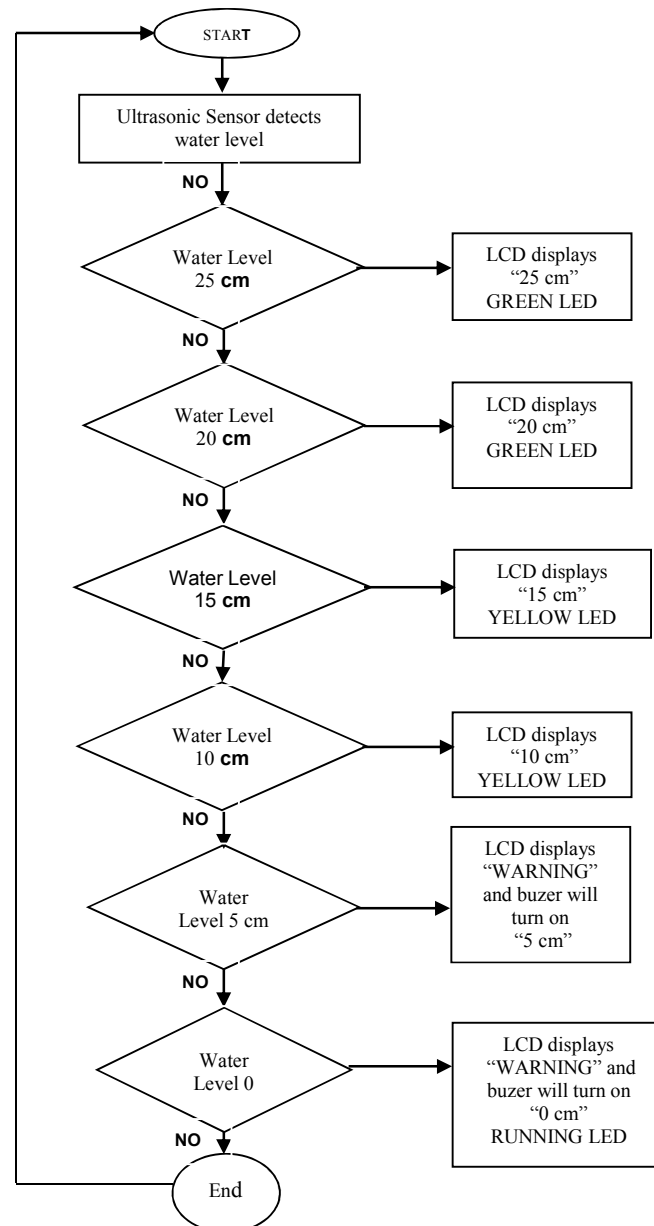

Figure 2 Flowchart of water level detection using ultrasonic sensor

### 3.3 Flowchart of Water Quality Detection Using pH Probe

Figure 3 shows the flowchart of water quality detection using pH probe. The pH probe will measure the pH value of water in the tank continuously. After that, the data from the sensor will be sent to microcontroller. The microcontroller will process the data and produce the consequent output to the output devices such as LCD, LEDs and buzzer. The LCD will display the value and the quality of water continuously.

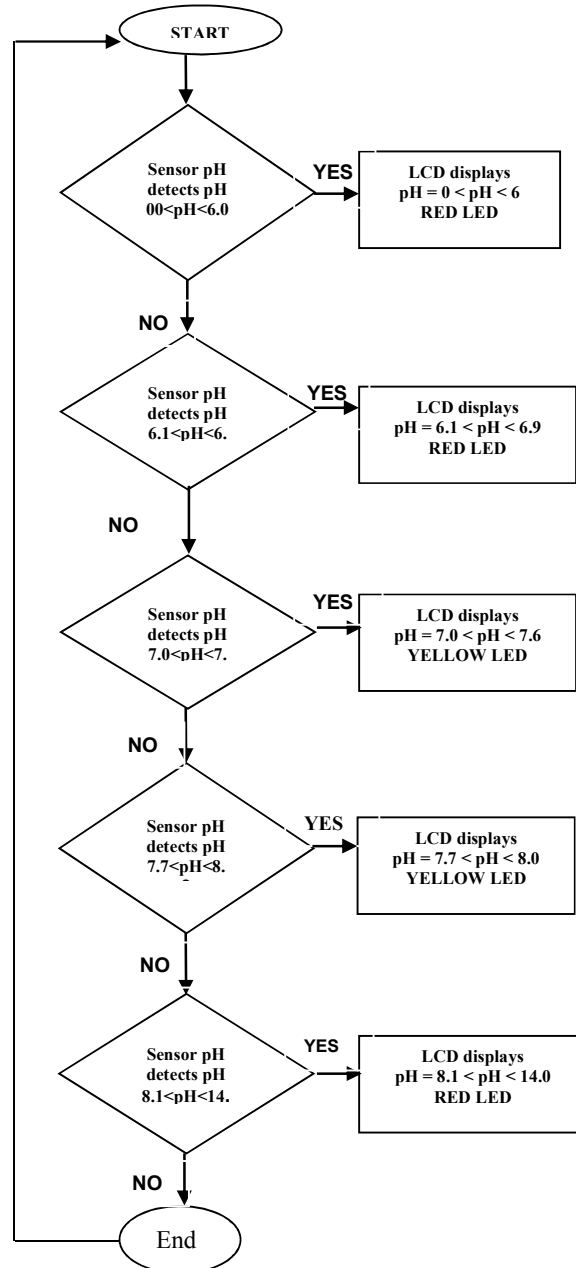

Figure 3 Flowchart of water quality detection using pH probe

## 4.0 RESULTS AND DISCUSSIONS

### 4.1 The project

The schematic diagram and the project simulation shown Figure 4 is done using Proteus 7 ISIS Professional software. The Arduino Uno board is used to substitute the basic circuit for ATmega328P microcontroller. The water level and pH probe sensors are interfaced with Arduino Uno board and the measured value is displayed using the LCD. In this project, the ultrasonic sensor is used as water level sensor. Then, the LCD which acts as output for this project will display the water level and pH values automatically.

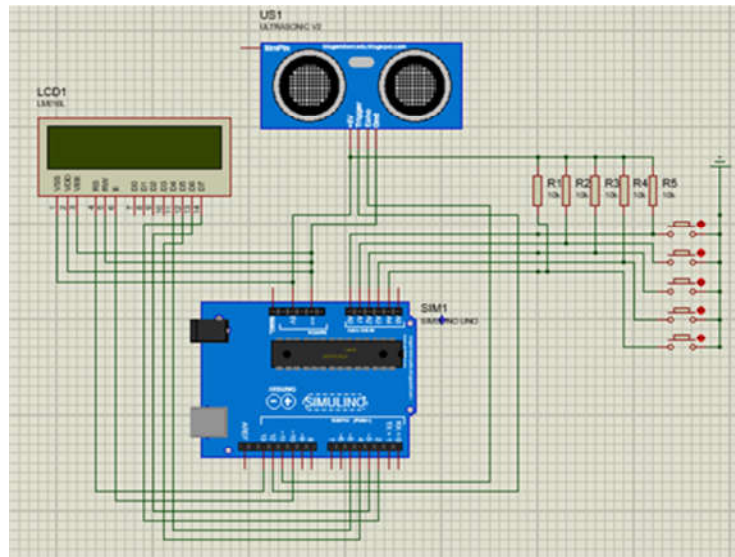

Figure 4 The schematic circuit for water level with ultrasonic sensor and pH sensor by using ATmega328P

### 4.2 System Components

1. Programmable Interface Controller (PIC): The microcontroller is a high-performance Atmel 8-bit AVR RISC with 32KB flash memory, 1024B EEPROM and 23 general purpose Input/Output lines. It also has 32 general purpose working registers, three flexible timer/counters, byte-oriented 2-wire serial interface, serial port and a 6-channel 10-bit A/D (Bharani et al., 2014).
2. pH probe: A sensor measures the water pH level. This pH probe has two basic components which are moving-coil meter (one with pointer against scale) and digital meter (one with a number display)
3. HC-SR04 ultrasonic sensor: The sensor consists of a transmitter and a receiver which are used to detect water level by sonar to determine distance of water level and change it to electrical signal. This sensor will be able to detect level of water between 2cm – 400cm which surely can detect water level in house tank.
4. Liquid crystal display: LCD is a thin, flat electronic visual display that uses the liquid crystal. The LCD output is used to display pH value and level of water simultaneously. Meanwhile, 2x16 LCD can display 16 characters with only two layers suitable for this project to display water level and pH.

## 5.0 CONCLUSION

This project can benefit the consumers to monitor the water level and quality in their homes continuously. This system is portable, convenient and consumes less power. However in this project, the limitation is the usage of battery as power supply to the circuit. This can be solved by using solar panel which is part of green technology as an alternative to limited power resources problem. Furthermore, enhancements can also be implemented on the system such as wireless monitoring systems or using remote control system or can also be intergrated through internet, thus making it possible to monitor the system anywhere and anytime.

## References

- Bartram, J., & Cairncross, S. (2010). Hygiene, sanitation, and water: forgotten foundations of health. *PLoS Med*, 7(11), e1000367.
- Bharani, M., Elango, S., Ramesh, S. M., & Preetilatha, R. (2014). An Embedded System Based Monitoring System For Industries By Interfacing Sensors With ATmega Microcontroller. *International Journal of Advanced Research in Electronics and Communication Engineering (IJARECE)*, 3, 1472-1474.
- Fisher, D. K., & Sui, R. (2013). An inexpensive open-source ultrasonic sensing system for monitoring liquid levels. *Agricultural Engineering International: CIGR Journal*, 15(4), 328-334.
- Harris, T., & Tech. W.F., (2016). Solid State Electronics. Retrieve from [http:// electronics .howstuffworks.com /led.htm](http://electronics.howstuffworks.com/led.htm)
- Hunter, P.R., MacDonald, A.M., & Carter, R.C. (2010). Water Supply and Health. *PLoS Med* 7(11): e1000361. doi:10.1371/journal.pmed.1000361
- Kuantama, E., Setyawan, L., & Darma, J. (2012). Early Flood Alerts Using Short Message Service (SMS). In *System Engineering and Technology (ICSET), 2012 International Conference on* (pp. 1-5). IEEE.
- Pahlén AB., (2016). The pH water pH and Chlorine values for good water quality. Retrieve from <http://www.pahlen.com/users-guide/ph-and-chlorine>
- Oram, B., (2015). The pH water. Retrieve from [http://www.waterresearch .net/index.php/ph](http://www.waterresearch.net/index.php/ph),