

CHARACTERISATION OF PRESSURE AND VELOCITY OF AIR FLOW THROUGH PERFORATED PIPE: EXPERIMENTAL AND COMPUTATIONAL APPROACH

*Helmisyah Ahmad Jalaludin,²Mohd Daniel Bakri Omar, ²Ow Chee Seng

*Faculty of Mechanical Engineering
Universiti Teknologi MARA (UiTM) Cawangan Terengganu, Bukit Besi Campus
23200 Dungun, Terengganu, Malaysia

² Faculty of Mechanical Engineering
Universiti Teknologi MARA (UiTM) Cawangan Selangor
40450 Shah Alam, Selangor, Malaysia

*Corresponding author's email: helmisyah@uitm.edu.my

Submission date: 02 Jan 2017 Accepted date: 22 February 2017 Published date: 15 May 2017

Abstract

Air flow distribution has become one of the most important components that contribute to Heating, Ventilation and Air Conditioning (HVAC) system. Recently, perforated pipe has been chosen to be included into the air flow distribution system due to its effectiveness in distributing air through perforated holes. In this paper, characteristics of air flow through perforated pipe are measured by experiment and computational simulation in order to investigate the pressure distribution as well as velocity distribution along the pipe. Basic equations such as momentum and continuity equations are used to calculate the air flow characteristics. Air flow characteristics through perforated pipe depends on many parameters such as pipe materials, size of hole, pipe diameter and fan speed which could lead to the variation of air flow characteristics. This research has been carried out to investigate the characteristics of the air flow through perforated pipe for the fan speed of 5, 10, 15 and 20 m/s. Also, the dimension for the apparatus has been scaled to a certain ratio that is going to be suitable for experimental investigation. Results show increment in the value of velocity through all four fan speeds. The pressure readings show pressure drop occurs from the inlet to the end of the perforated pipe. Surface roughness of inner pipe and turbulence characteristic at the end of pipe could be the cause of pressure drop and velocity fluctuation.

Keywords: *perforated pipe; airflow; distribution; pressure; velocity*

1.0 INTRODUCTION

Heating, Ventilation and Air-Conditioning (HVAC) system are major and vital components that have been widely used in building nowadays whether in residential or commercial premise. For modern and future time, as the density of growth is getting higher mostly in a metropolitan city, the need for proper HVAC design increases rapidly (Rezwan et al., 2012). From the statement, it is not only the needs using of HVAC that leads to good quality life, but the design of the HVAC is firstly needed to be considered before installing in a building. It is important to maintain a good indoor air quality and surrounding for a better way of living.

Air flow distribution is the characteristic of air according to a particular space or condition. A previous study has been done on investigating the effect of localizing air conditioning with occupancy control in an open office. The project was set to be created an isolated environment using a multiple slot diffuser to supply the air and a return vent to control the spreading out of air movement. Before the air flow mixes with the air in a room or space, it will pass through a supply grille. The supply grille is then spreads the air according to the design of the grille with certain velocity and pressure. It is said that the design of grille might lead to an amount of noise at the outlet of the grille. Deficiencies in duct design could result in systems that operate incorrectly. Poor design or lack of system sealing could produce inadequate air flow rates at the terminal, leading to discomfort, loss of productivity, and even adverse health effects. Lack of sound attenuation might lead to objectionable noise levels as well. Proper duct insulation eliminates excessive heat gain or loss (Lo & Novoselac, 2010; Khalil, 2012).

2.0 BACKGROUND/LITERATURE REVIEW

Existing ducting system has been generally updated from the aspects of effectiveness, cost, service and maintenance etc. Recently, the usage of perforated pipe has been consumed in the HVAC system due to its effectiveness in the distribution of air flow through the perforated holes. Commonly, before the invention of perforated type ducting, a direct air flow distribution has been used where the air treated is supplied from the power source to the air distributor such as diffuser and grill (Wulfinghoff, 2011; Gurav, Gaikwad & Purohit, 2012).

Analytically, the characteristic of the air flow through perforated pipe should be studied and investigated in order to predict the velocity distribution as well as the pressure distribution along the length of the pipe. However, it is sufficient for the study to apply only a part of the length that can be taken into consideration in order to validate the investigation. Basic equations for the study such as conservation of mass, energy and continuity equations should be used in order to analyze the air flow characteristic. Even though these equations are only applied for a fully developed flow of air where the scenario might not be seen in perforated pipe, however the equations provide a very useful result in terms of important parameters such as velocity and pressure along the pipe (Farajpourlar, Janaun & Kariman, 2015).

Previous study about perforated ducting that was made by researchers is regarding on effect of changing the blockage ratio (BR) of the multi-perforated tubes. Also, the study also means to study the effect changing the thickness on the tube on the exit flow characteristics. The study is done by conducting an experimental procedure and analytical simulation. The result for the experiment shows that the internal and external flow characteristics are influenced by the geometrical variables as the value of the BR by changing the pressure inside the tube. For the effect of thickness of multi-perforated tubes on the characteristics of air flow, the result obtained shows that, when the thickness of the tube used is 10mm, it results in a higher flow rate compared to the tubes of size 2mm with a tendency of more uniform flow rate distribution between the orifices or the perforation. The slope of the flow rate distribution is almost the same for both cases (Lee, Moon & Lee, 2011).

Another previous study was conducted on the principles of energy and momentum conservation to analyze and model air flow for perforated ventilation ducts. This study was done by developing a theoretical modeling in order to predict the pattern of the air distribution where the design is needed for the perforated ventilation installed with a fan. For a more approximated result, there are several experiment methods tested and compared besides using an appropriate tools such as piezometric flush tape and thermo-anemometer to measure the air pressure of the duct and the air flow at the outlet respectively. Also, regardless of the frictional losses, the air flow performance for the perforated ventilation ducts was formulated based on the equations of energy momentum and conservation of momentum in order to evaluate the outlet discharge angle and the duct angle regain coefficients. The

results were compared between four wooden perforated ventilation ducts with the aperture ratios of 0.5, 1.0, 1.5, and 2.0. There was a 9% maximum error from the result where the flow in the ventilation ducts was operated under turbulent flow conditions (Lee et al., 2011).

In analysis of fluid flow in the pipe, the law of conservation of mass and energy state that for any system closed to all transfers of matter and energy whereby the mass of the system must remain same over the period as the quantity of the mass cannot be changed if it is not be removed or added. It is becoming the default in the closed system since there is no mass leaves or enters the system. For steady flow processes, the equation can be modified as:

$$\sum m_{in} - \sum m_{out} = 0 \quad (1)$$

And for the flow through a pipe or duct, the mass flow rate is related to the velocity by:

$$\dot{m} = \rho VA = \frac{VA}{v} \quad (2)$$

In the conservation of momentum of fluid flow analysis, the common equation used in the calculation is linear momentum equation. Newton's Second Law for a system of m subjected is expressed as:

$$\sum \vec{F} = m\vec{a} = m \frac{d\vec{v}}{dt} = \frac{d}{dt}(m\vec{v}) \quad (3)$$

which are $m\vec{v}$ is the linear momentum of the system. By considering the density and velocity may change from point to another point in the system, Newton's Second Law can be expressed as:

$$\sum \vec{F} = \frac{d}{dt} \int \rho \vec{v} dV \quad (4)$$

Since most flow systems are analyzed using control volume formulation, the Reynold's Transport Theorem is expressed for linear momentum as:

$$\sum \vec{F} = \frac{d}{dt} \int \rho \vec{v} dV + \int \rho \vec{v} (\vec{v} \cdot \vec{n}) dA \quad (5)$$

According to Bernoulli's Principle, which enables to determine the relationship between the pressure, density and velocity at every point in a fluid, shows that as the velocity of fluid flow increases, its pressure will decrease. The sum of pressure, P , the kinetic energy per unit volume $\frac{1}{2}\rho v^2$ and the gravitational potential energy per unit (ρgy) has the same value all points along a streamline. The equation can be expressed as:

$$P_1 + \frac{1}{2}\rho v_1^2 + \rho gy_1 = P_2 + \frac{1}{2}\rho v_2^2 + \rho gy_2 \quad (6)$$

Velocity is expressed as the rate of change of distance with respect to particular time (Cengel & Cimbala, 2010). For the study of velocity for the air flow, the velocity can be described as the range values of speed that contributes to the different types of air flow characteristic. The characteristic of the air flow can be measured through the application of Reynold Number principle. Reynold number stated that there are three types of flow which are laminar, transitional and turbulence flows. These flows can be differentiated between the characteristic. For Reynold number characteristic in circular pipe are as follow:

$Re \leq 2300$:Laminar flow
$2300 \leq Re \leq 4000$:Transitional flow
$Re \geq 4000$:Turbulence flow

Reynold number can be calculated by using the following equation:

$$Re = \frac{\text{Inertial Forces}}{\text{Viscous forces}} = \frac{V_{avg}D}{\nu} = \frac{\rho V_{avg}D}{\mu} \quad (7)$$

where the cross-sectional area for the pipe is:

$$A = \pi r^2 \quad (8)$$

Pressure at any point at the same in a fluid will be equal even though there is no direct horizontal path between those points. In piping system for HVAC, a method called static regain method is used in order to apply the similar method as above. The static regain method the air velocity systematically in the direction of flow in such a way that the increase or regain in static pressure. This method is suitable for the case of high velocity from the inlet, control volume systems having long runs of duct with many takeoffs. Some formula for pressure that is used in this project is the static pressure and total pressure.

$$\text{Total pressure} = P_{static} + \frac{1}{2}\rho + V^2 \quad (9)$$

3.0 METHODOLOGY

In this paper, characteristics of air flow through perforated PVC pipe are measured by experiment and computational simulation in order to investigate the pressure distribution as well as velocity distribution along the pipe. Basic equations such as momentum and continuity equations are used to calculate the air flow characteristics. Air flow characteristics through perforated pipe depends on many parameters such as size of hole, pipe diameter, fan speeds and others as shown in Table 1, which could lead to the variation of air flow characteristics. This research has been carried out to investigate the characteristics of the air flow through perforated pipe for the fan speed of 5, 10, 15, and 20 m/s.

Table 1 Parameters of Perforated Pipe for Experimental and Simulation Approach

Length Without Hole (mm)	278.0
Diameter Per Hole (mm)	13.5
Total Pipe Length (mm)	2106.0
Fan Speed (m/s)	5, 10, 15, 20
Inlet Pressure (Pa)	Depend on fan speed
Pipe Diameter (mm)	1100
Pipe Roughness (μm)	1.29
Totak Number of Hole	16
Air Flow Density (kg/m^3)	1.2
Dynamic Viscosity (Pa.s)	0.0002

In this research, ASHRAE Standard 70-2006 is used to measure the parameters of the air flow characteristics. Pitot tube is used to measure the pressure at the specific location where the manometer is connected to the Pitot tube by means of wire tube and readings were recorded by the difference in level of oil in the manometer. For the velocity measurement, hotwire anemometer is used by placing the hotwire probe at the specific location. Also, the dimension of the duct was designed and fabricated according to

the standard where the length for the duct from the inlet fan must be minimum at least triple length of the diameter for the duct as shown in Figure 1.

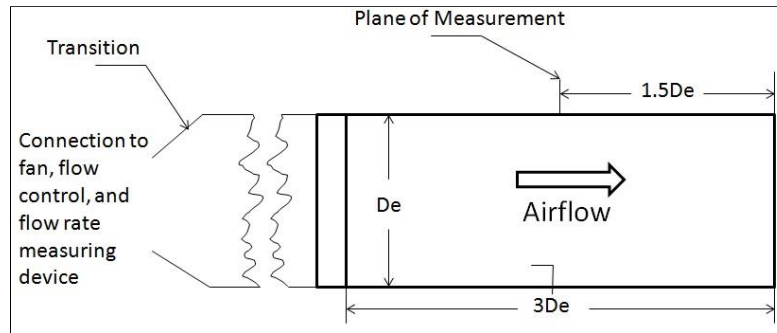

Figure 1 Schematic for minimum length for pipe installation

Experimental investigation are carried out as all of the assembly between the pipe and the blower already done as shown in Figure 2(a). This experiment is done at the fluid mechanics lab where the surrounding is suitable for the purpose of setting up and conducting experiment for the investigation of characteristics of air flow distribution through perforated pipe. Surface roughness is neglected during pressure and velocity measurement. The first section of the pipe is about 1100 mm because it is the minimum length for the pipe with the diameter size of 110 mm to achieve a fully developed flow before it reaches the perforated holes. The pipe is drilled for 8 holes on the both sides with size of approximately 13.5 mm each. All of the readings for the velocity and pressure are taken from the 8 holes. The pipe is connected with a fan to feed air supply at one end of the pipe, while at the other end of the pipe is closed with pipe stopper which is at the same section with perforated holes.

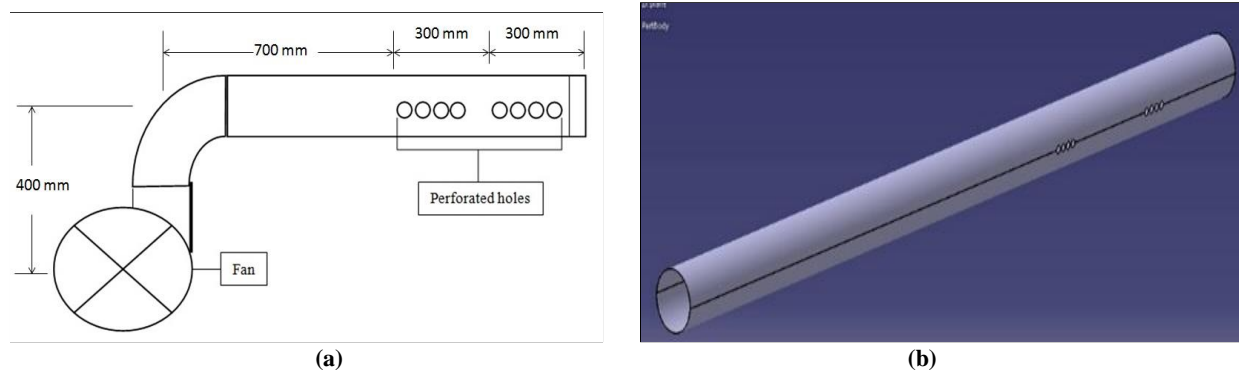

Figure 2(a) Schematic diagram for pipe installation for experiment, and (b) Model of Perforated Pipe for Simulation

Computer simulation is carried out after the pipe modelling is designed using CATIA V5R20 software. The model of perforated pipe is design as the same dimensions and parameters as the experimental one as shown in Figure 2(b). Even though equations derived are based on fully developed flow of air through pipe in which it may not occur in case of perforated pipe, the equation derived are useful for providing baseline values of important parameters such as pressure and velocity along the pipe which is helpful in designing an air flow distribution system through perforated pipe. Since the flow inside the perforated pipe may not always be fully developed flow throughout the pipe, results obtained may vary from the theoretical study. The result from the experiment is mainly to discuss about the value of pressure and velocity at the perforated holes. It is also to discuss the comparison between the results from the analysis simulation using the computer software with the experimental investigation.

4.0 RESULTS AND DISCUSSION

Figure 3(a) shows almost the same pattern for fan with speed of 5, 10, and 15 m/s, where the readings area continuously increasing throughout the pipe. However, for the fan speed of 20 m/s, the graph is fluctuated at the end of the end of the perforation where the value is drastically decreased from 4th to the 5th perforation. This might because of tendency of turbulence flow generation during air hitting pipe stopper. Speed of air at the perforated holes continues to increase till the end of the perforated holes.

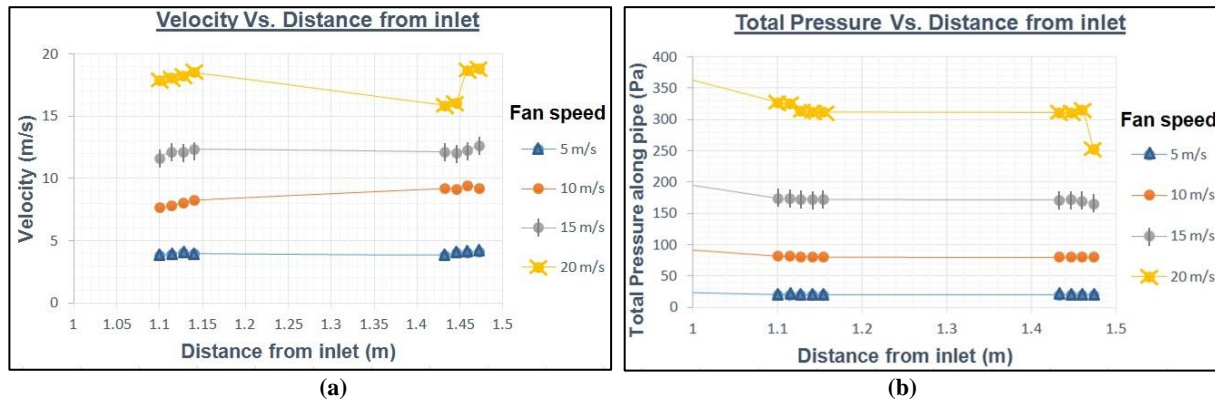

Figure 3 (a) Graph of velocity at the perforated holes, (b) Graph of total pressure distribution along the pipe

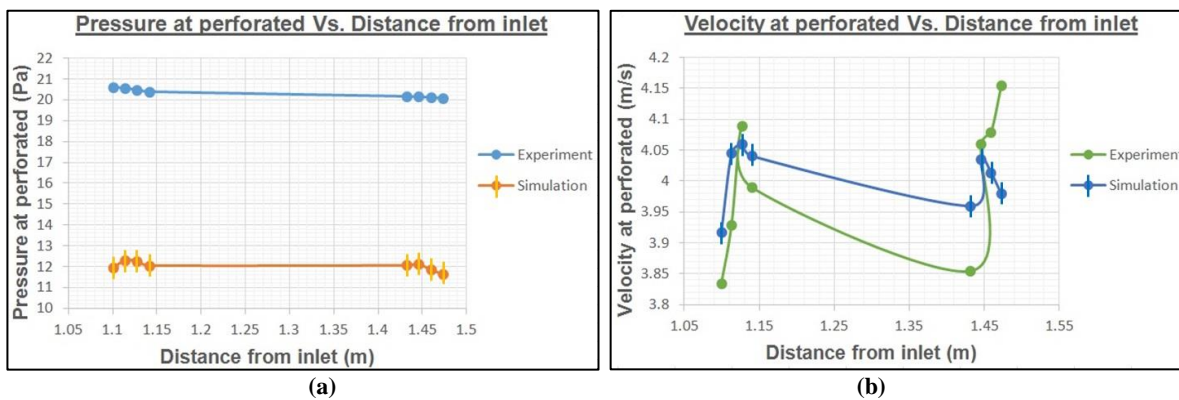

Figure 4 (a) Pressure distribution comparison between experimental and simulation at 5 m/s, (b) Velocity distribution comparison between experimental and simulation at 5 m/s

For the pressure reading along the perforated holes with fan speed of 5, 10, and 15 m/s, Figure 3(b) shows almost the same pattern for all where the readings area continuously decrease throughout the pipe. However, for the fan speed of 20 m/s, pressure drop occurs at the two last perforations. The speed of air at the perforated holes continues to decrease till the end of the perforated holes for all of the fan speed since air might be leak out through perforation.

Almost the same pattern for each pressure distribution during 5 m/s fan speed where the readings area continuously decreasing throughout the pipe for both experiment and simulation methods as shown in Figure 4(a). However, for the experimental, the value is high ranging from 20.6 to 20.1 Pa with a pressure drop of 0.5 Pa while for the simulation shows there is also a decrement from 11.9 to 11.6 with a pressure drop of 0.3 Pa. Surface roughness of inner pipe might be the cause of different pressure since there is no roughness set for simulation.

In Figure 4(b), the velocity at perforated both experimental and simulation show almost the same reading. The velocity for the simulation is ranging from 3.91 to 4.01 m/s while the speed for experiment is ranging between 3.83 to 4.15 m/s. However, the speed could not be achieved the original value which is 5 m/s for both simulation and experiment cases since there might be condition constraint on the simulation.

5.0 CONCLUSIONS

As a conclusion, the velocity of the air flow through perforated pipe post the similar pattern of graph although the fan speed is changed from 5 to 20 m/s. There are increments in the value of velocity through each fan speeds. However, the 20 m/s speed shows a complex characteristic at the end of the perforation. Ironically, the pressure reading is decreased from the inlet to the end of the perforated pipe.

For the comparison between the simulation and experiment, the pattern of the graphs for the pressure and velocity are similar for both cases. The pressure reading for the experiment is higher than the simulation result by 9 Pa. The velocity for the simulation and pressure also show the same result where the ranges for the reading are the same for 3.8 to 4.16 m/s. However, the reading for the two last perforated experiment is increased while decreased for the simulation. Surface roughness of inner pipe and turbulence characteristic at the end of pipe could be the cause of pressure drop and velocity fluctuation.

References

- Cengel, Y.A. & Cimbala, J.M. (2010). *Fluid Mechanics: Fundamentals and Application* (2nd ed.). Singapore: Mc-Graw Hill.
- Farajpourlar, M., Janaun, J. & Kariman, A. (2015). Gas flow through vertical pipe and perforated vertical pipe. *Int. Journal of ChemTech Research*, 7(6), 2589-2595.
- Gurav, R., Gaikwad, S. & Purohit, P. (2012). Duct Design Using Equal Friction Method and CFD. International Conference on Recent Technology (pp. 1-7).
- Khalil, E.E. (2012). Energy Efficient Hospitals Air Conditioning System. *Open Journal of Energy Efficient 1, Scientific Research*, 1-7.
- Lee, S., Moon, N. & Lee, J. (2011). A Study on the Exit Flow Characteristics Determined by the Orifice Configuration of Multi-Perforated Tubes. *Journal of Mechanical and Science Technology*, 26(9), 2751-2758.
- Lo, L.J. & Novoselac, A. (2010). Localized air-conditioning with occupancy control in an open office. *Energy and Buildings*, 42(7), 1120-1128.
- Rezwan, A.A., Kabir, T.M.H., Arefin, A.K.M.H., & Sarkar, M.A.R. (2012). Numerical Investigation of Flow Characteristics inside a HVAC Duct: The case study in a commercial building. Proceeding of the 6th International Mechanical Engineering Conference & 14th Annual Paper Meet. Dhaka, Bangladesh.
- Wulinhoff, D.R. (2011). Multiple-zone HVAC: An Obsolete Template. *Energy Engineering*, 108 (2), 44-56.