



UNIVERSITI  
TEKNOLOGI  
MARA



# Globalising Knowledge and Information

## SCIENCE TECHNOLOGY

## NATIONAL SEMINAR ON

## SCIENCE TECHNOLOGY & SOCIAL SCIENCES

## 2006

30-31 May 2006

Swiss Garden Resort & Spa  
Kuantan, Pahang

## STRESS ANALYSIS OF *Acacia Mangium* FURNITURE BY COMPUTER AIDED DESIGN AND ENGINEERING ANALYSIS

Mohd Ariff Jamaludin  
Mansur Ahmad  
Kamarulzaman Nordin

### ABSTRACT

A finite element analysis of a simple design chair was carried out in this study. A vertical static load was applied at the centre point of the seat and another horizontal static load was applied on the centre point of the backrest simultaneously. Three sets of load of 900N (90kg) and 380N (38kg); 1800N (180kg) and 760N (76kg); and 3600N (360kg) and 1520N (152kg) were applied on the seat and on the backrest respectively. The maximum stresses for these three different load levels were 5.9173N/mm<sup>2</sup>, 11.8346N/mm<sup>2</sup> and 23.6698 N/mm<sup>2</sup> respectively. The load versus stress relationship indicated that the yield stress was proportional to the applied load. At higher load level the yield stress on the modelled chair was also higher. Stress concentration occurred at the end joints; at the centre of the backrest and the seat, and the mid span of the front and back seat rails. Stress located nearer to the end joint had higher stress values than the stress located away from the end joint. The chair fulfilled the performance criteria in BS 4875(1985) and BS 5873 (1980, 1991) for the chair size mark 4 and 5 under normal and severe rating. The modelled chair did not fail even when the applied load had been increased to twice of the load requirements in the BS 4875(1985) and BS 5873 (1980, 1991) tests standard.

### Introduction

CAE analysis will be a new approach in furniture design. Currently, furniture manufacturers study stresses in furniture through mechanical tests. These tests are destructive, time consuming and not economically practical. This method of CAD and CAE analysis has several advantages. FEM module within the CAE software is capable of handling non-homogeneous problems in wood furniture. The test environment can be specified in FEM analysis, therefore the main sources of error such as site factors can be controlled. The boundary condition can be represented in FEM. CAE is a virtual stress analysis which does not actually apply real loads on real test specimens until failure. As a result, the cost due to destructive research can be minimised. FEM also is able to suggest minor changes in the furniture design to get better performance from the stress analysis prior to the construction of the real furniture. In mechanical test, stress analysis can only be done on stress concentration in selected points using sensors but by using FEM in CAE analysis, the region of stress can be differentiated visually from all parts of the furniture based on the stress contour output.

Currently, furniture designers do not use CAE software in furniture designing. This project was a preliminary study of CAE software application in furniture designing. The main objective of this project was to study the distribution of stresses in *Acacia mangium* furniture as it reacts to an applied load on the seat rest and the backrest using the CAE analysis software prior to construction.

### Materials and Methods

The chair design chosen for this research was based on a commercial design intended to conform to BS 4875 (1985) and BS 5873 (1980,1991) performance criteria. The chair was 840.0mm in height, 420.8mm in width and 416.0mm in depth. This chair was modelled in a CAD software and analysed using a CAE software package.

The members of the front rail joint assembly were modelled using three- dimensional four node tetrahedron (3D 4N) solid elements. The properties of each member of the front rail joint assembly were taken into account. The Poisson's ratio effects were  $\nu_{xy}$ ,  $\nu_{xz}$ ,  $\nu_{yx}$ ,  $\nu_{yz}$ ,  $\nu_{zx}$  and  $\nu_{zy}$  which were expressed in terms of their local co-ordinates as  $\nu_{LT}$ ,  $\nu_{LR}$ ,  $\nu_{TR}$ ,  $\nu_{TL}$ ,  $\nu_{RL}$  and  $\nu_{RT}$ .

The construction of furniture was assumed to be perfect. The global X-axis was along the horizontal plane of the front rail along the length. The global Y-axis was in the vertical plane along the length of the legs. The global Z-axis was perpendicular to the X and Y-axes along the side rail. The global axes were with respect to the whole chair whereas the local axes were with respect to each component. The local co-ordinates system x, y, z for each component were parallel to the longitudinal direction of the grain, radial to the direction of growth ring and tangential to the direction of growth ring, respectively. These three directions are as shown in Figure 7. The legs were restrained in X-, Y-, Z- translations and in X-, Y-, and Z- rotations. For this study, the bottoms of the legs were

restrained from moving in any directions to simulate that the chair was placed on the floor and is not moving.

It was assumed that the body weight of a person sitting on the chair would be distributed along various parts of the furniture. A majority of this weight would be exerted on the rails, which hold the seat. In the CAE analysis, one vertical static load was applied to the centre point of the seat for seat static load test and another horizontal static load was applied on the centre point of the backrest for back static load test simultaneously, which represented a seated person. This was done in accordance to BS 4875 (1985) and BS 5873 (1980,1991) standard for educational furniture tests performance criteria for chair size mark 4 and 5 in normal and severe rating service conditions, respectively.

Two solid cylinders measuring 20.0mm in radius and 20.0mm in height were designed conjointly on the loading points of the modelled chair to imitate the load cells in seat and back static load tests whereby the loads were applied on the surface of the cylinders. The stresses that was induced in these two cylinders was not recognised as stress distribution in the modelled chair. In this study, three sets of loads of 900N (90kg) and 380N (38kg); 1800N (180kg) and 760N (76kg); 3600N (360kg) and 1520N (152kg) were applied on the surface of the cylinders on the seat and the backrest respectively.

In the CAE analysis, the material used for analysing the modelled chair was assigned to the mesh. The material properties for *Acacia mangium* were created in the materials matrices in the finite element analysis. The input data for MOR, MOE, ultimate stress and mass density were obtained from literatures cited whereas the input data for the Poisson's ratio was obtained from a simple test that was conducted prior to the CAE analysis (Table 5). The other input parameters in

**Table 1** : Poisson's ratio of *Acacia mangium*

	Strain in the direction perpendicular to load	Strain in the direction of load	Poisson's ratio
Specimen A	1.823	3.043	$\nu_{LR} = 0.5991$
	0.201	3.145	$\nu_{LT} = 0.0639$
Specimen B	31.719	57.432	$\nu_{RL} = 0.5523$
	2.364	38.528	$\nu_{RT} = 0.0614$
Specimen C	36.255	70.787	$\nu_{TR} = 0.5122$
	2.843	54.219	$\nu_{TL} = 0.0524$
Poisson's Ratio (Average)	$\nu = 0.3069$		

Note:

Appendices 3, 4, 5, 6, 7, 8 and 9

**Table 2** : Material Properties for *Acacia mangium*

Parameter	Value
Young's Modulus, N/mm <sup>2</sup> (MOE)	10891 <sup>a</sup>
Poisson's Ratio, $\nu$ [MC = 12%]	0.3069
Mass Density, kg/m <sup>3</sup>	570 <sup>b</sup>
Ultimate Stress, N/mm <sup>2</sup>	48.49 <sup>c</sup>
Maximum Yield Stress, N/mm <sup>2</sup> (MOR)	97 <sup>d</sup>

Note:

<sup>a</sup> Razali and Hamami (1992)

<sup>b</sup> Razali and Hamami (1992)

<sup>c</sup> Tham (1979)

<sup>d</sup> Razali and Hamami (1992)

slats were experiencing higher stresses at locations nearer to the end joints than locations away from the end joints (Figures 16 and 17). The stresses at the joints between the side slats and the front legs were lower than the stresses at joints between the side slats and the back legs. This occurred as a result of the displacement of the backrest and the back legs induced by the horizontal static load that was applied at the centre of the backrest. The load induced stresses and displaced the backrest and back legs in Z- direction (backward). The end joints between the side slat and the front leg were under compression whereas the end joints between the back legs and the side slats were under tension. The end joints of both of the seat side rails and side slats would tend to slip due to the abusive or improper sitting practices. For example, sitting on the chair with two front legs hanging.

The modelled chair did not fail after being tested by a set of horizontal static load of 760N and vertical static load of 1800N. Therefore, this modelled chair had passed the backrest and seat static tests for educational furniture size marks 4 and 5 for both normal and severe rating under BS 4875 (1985) and BS 5873 (1980,1991) performance criteria.

The modelled chair did not fail also when the load applied was twice of the load requirement in BS 4875(1985) and BS 5873 (1980, 1991) for the chair size mark 4 and 5 under severe rating. The applied loads were 3600N (360kg) for the backrest and 1520N (152kg) for the seat rest. Evidently, the chair might be over designed in which it had been modelled by using excessive material.

## Conclusion and Recommendation

The maximum stress recorded for the set of applied load of 380N horizontal load and 900N vertical load was 5.91730N/mm<sup>2</sup> whilst the maximum displacement was 1.50241mm. The maximum stress recorded for the test by a set of horizontal static load of 760N and 1800N vertical static load was 11.8346N/mm<sup>2</sup> and the maximum displacement was 3.00483mm. The maximum stress recorded for the test by a set of horizontal static load of 1520N and 3600N vertical static load was 23.6698N/mm<sup>2</sup> and the maximum displacement was 6.00952mm. Based on the results, it can be concluded that the predicted yield stress is increased due to the increment of the applied load.

The size of mesh element can be reduced to minimise the maximum computed errors in the stress analysis. This increases the confidence levels and accuracy of the stress analysis results. The stress analysis of the modelled chair can be further improved by analysing the modelled chair by introducing the six Poisson's ratios of *Acacia mangium* in three different load directions that are  $\nu_{LR}$ ,  $\nu_{LT}$ ,  $\nu_{RT}$ ,  $\nu_{RL}$ ,  $\nu_{TR}$  and  $\nu_{TL}$ . As such anisotropic characteristics of *Acacia mangium* will be taken into account in the stress analysis and thus generate a better results.

The chair fulfilled the performance criteria of BS 4875(1985) and BS 5873 (1980, 1991) for the chair size mark 4 and 5 under normal and severe rating. The modelled chair did not fail eventhough the applied load had been increased to twice of the load requirements in the BS 4875(1985) and BS 5873 (1980, 1991) tests standard. Based on the result, it can be concluded that the modelled chair had been over designed and the design of the chair can be further enhance by reducing the dimension of the parts and components.

This modelled chair had been designed with the assumption that all the parts and components were jointed continuously face to face. Therefore in future research, fasteners and dowels can be modelled into the modelled chair to study the stress distribution at the critical joint areas.

Besides that, the restraints that had been fixed at the bottoms of the modelled chair can be altered into restraints only at one edge of the back legs. This will take into consideration the stress distribution in an *Acacia mangium* chair due to improper sitting posture because it is a habit for some people to sit on the chair abusively.

The CAE software analysed the modelled chair and the induced stresses were presented as predicted values. The induced stress distribution can be validated by comparing it to the results from an actual laboratory experiment.

## References

- Anon, 1983. *Mangium and Other Acacias for the Humid Tropics*. National Research Council, Washington D.C.: National Academy Press.
- Anon, 1998. Poisson's Ratio. <http://ipddev.hp.ac.sg/lcs1/poisson.htm>. Download of article : 30<sup>th</sup> May 1999.
- Jamaludin, M. A. & P. R. Arora, 1999. Strength Evaluation Of Two Seater Sofas, Part-1A Finite Element Analysis Study, In *Proceedings of World Engineering Congress 1999 – Mechanical and Manufacturing Engineering*; 369-371: Universiti Putra Malaysia.
- Mohd Zin J., Jewan, D and M. H. Sahri 1991. Physical And Mechanical Properties Of *Acacia mangium* Willd. Of selected ages grown in Malaysia. In *Recent Developments in Tree Plantations of Humid/Subhumid Tropics of Asia*, eds. Sheikh Ali Abod et al. ; 774–781 Proc. Of a regional symposium held June 5-9, 1989 in Serdang, Malaysia. Serdang: Universiti Putra Malaysia.

Razali A.K & M. Hamami.S, 1992. Processing and Utilization of *Acacias*, focussing on *Acacia mangium*. In *Tropical Acacias in East Asia and he Pacific*, eds. Kamis Awang and D.A. Taylor; 86-89. Proc. Of a first meeting of the Consultative Group for research and Development of *Acacias* (COGREDA) held in Phuket, Thailand, June 1-3, 1992, Bangkok: Winrock International

Russ J.C, 1995. Poisson's Ratio in VIMS. Chapter 6, II, C. [http://vims.ncsu.edu/contents/CH.06/Section.11/Subsection c/](http://vims.ncsu.edu/contents/CH.06/Section.11/Subsection.c/).Download of article : 30<sup>th</sup> May 1999.

---

MOHD ARIFF JAMALUDIN, Research Scientist, Institute of Tropical Bio-Composite, 43400 UPM Serdang, Selangor Malaysia

MANSUR AHMAD AND KAMARULZAMAN NORDIN, Lecturer, Faculty of Applied Sciences, Universiti Teknologi MARA. 40450 Shah Alam. Selangor. Malaysia.

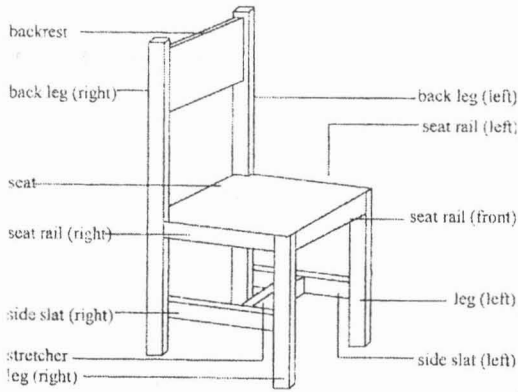

Fig 2: Design of the Acacia Mangium chair.

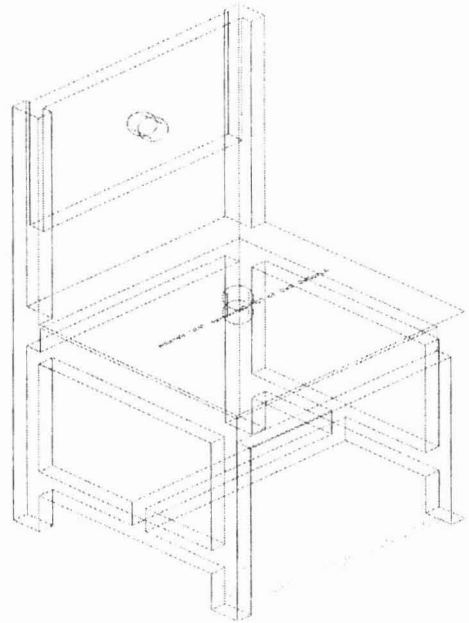

Fig 3: The chair as in the CAD software.

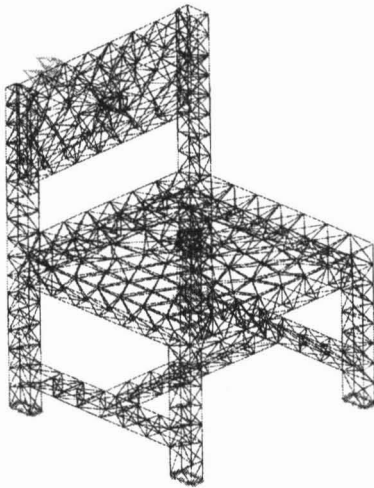

Fig 4: The isometric view of the meshed modelled chair in CAE package.

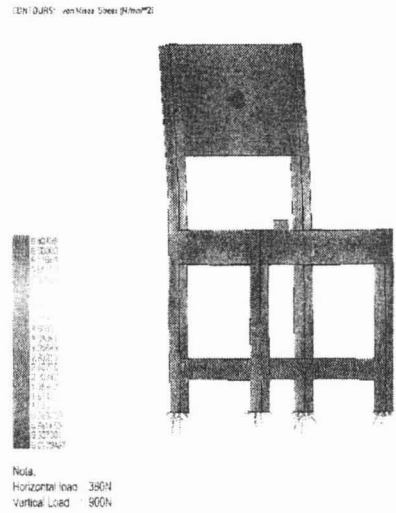
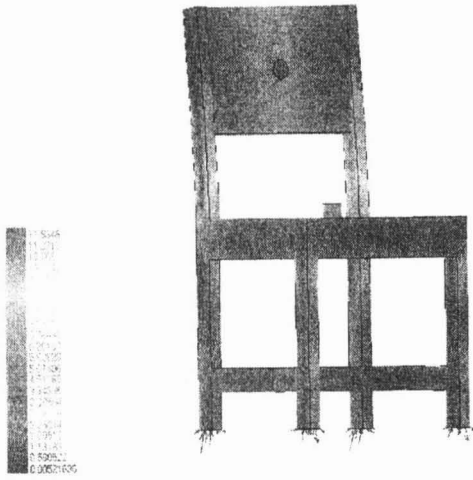

Fig 5: Front isometric view of the modeled chair with the Von Mises Stress contour induced by a set of 380 (backrest) and 900N (seat) loads.

CONTOURS: von Mises Stress (N/mm<sup>2</sup>)



Note:  
Horizontal load : 760N  
Vertical Load : 1800N

Fig 6: Front isometric view of the modeled chair with the Von Mises stress contour induced by a set of 700N (backrest) and 1800N (seats) loads.

CONTOURS: von Mises Stress (N/mm<sup>2</sup>)

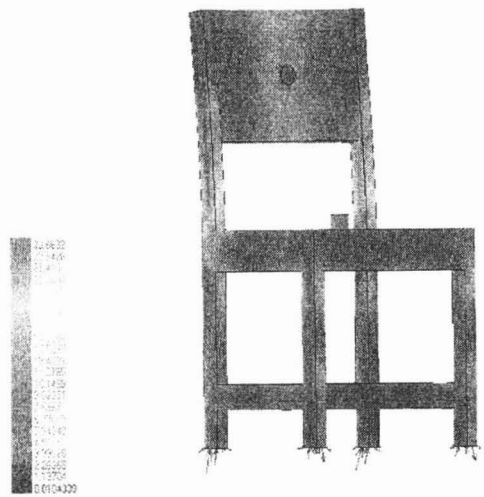

Note:  
Horizontal load : 1520N  
Vertical Load : 3600N

Fig 7: Front isometric view of the modeled chair with the Von Mises stress contour induced by a set of 1520N (backrest) and 3600N (seats) loads.

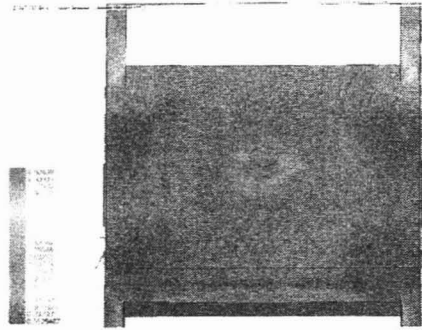

Note:  
Horizontal load : 380N  
Vertical Load : 900N

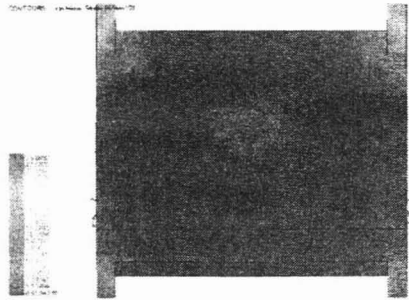

Note:  
Horizontal load : 380N  
Vertical Load : 900N

Fig 9: Comparison of Von Mises stress contour of the modeled chair with two different load levels (top isometric view focused on the seat).

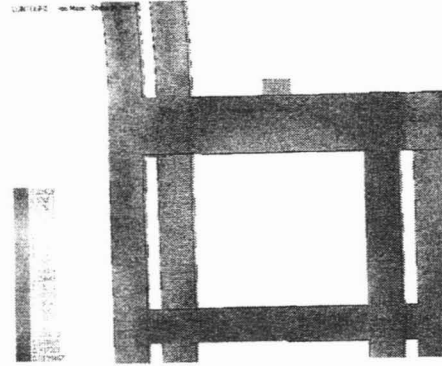

Note:  
Horizontal load : 380N  
Vertical Load : 900N

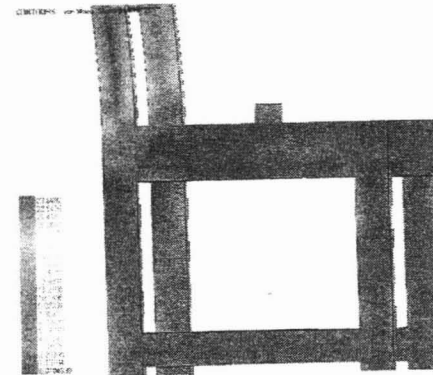

Note:  
Horizontal load : 1520N  
Vertical Load : 3600N

Fig 8: Comparison of Von Mises stress contour of the modeled chair with two different load levels (left isometric view near the seat rails).



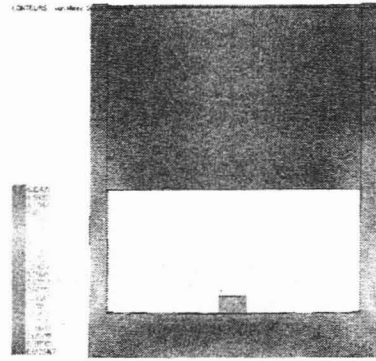

Note:  
Horizontal load : 380N  
Vertical Load : 900N

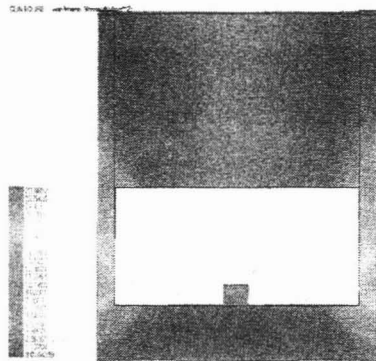

Note:  
Horizontal load : 1520N  
Vertical Load : 3600N

Fig 11: Comparison of Von Mises stress contour of the modeled chair with two different load levels (back view focussed on backrest, the back legs and the back seat rails)

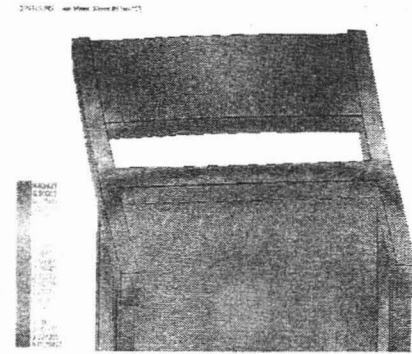

Note:  
Horizontal load : 380N  
Vertical Load : 900N

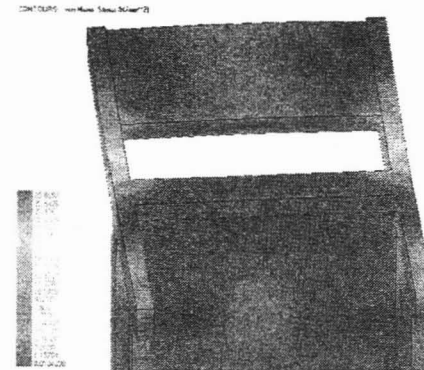

Note:  
Horizontal load : 1520N  
Vertical Load : 3600N

Fig 10: Comparison of Von Mises stress contour of the modeled chair with two different load levels (bottom isometric view).

CONTOURS von Mises Stress (N/mm<sup>2</sup>)

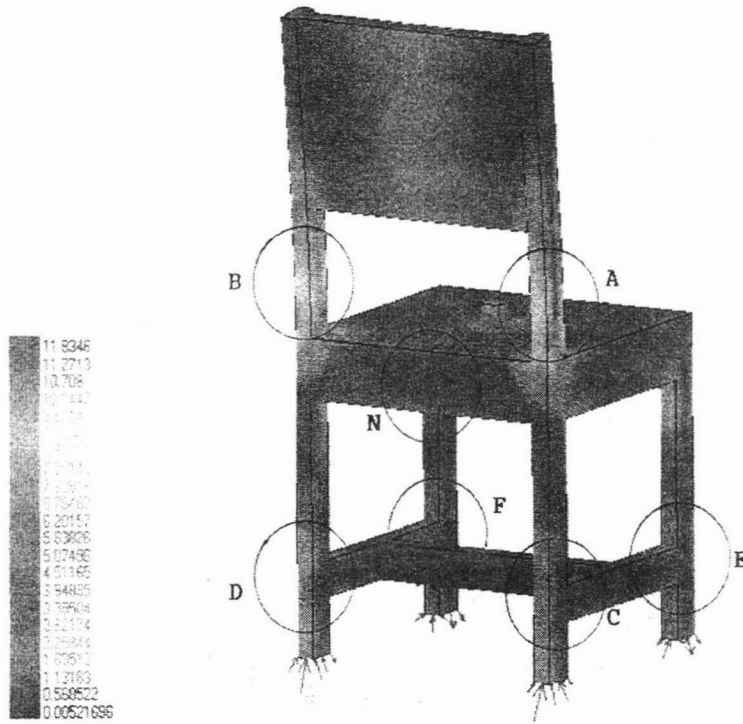

Note:  
Horizontal load : 760N  
Vertical Load : 1800N

Fig 13: Back isometric view of the modeled chair Von Mises stress contour

CONTOURS von Mises Stress (N/mm<sup>2</sup>)

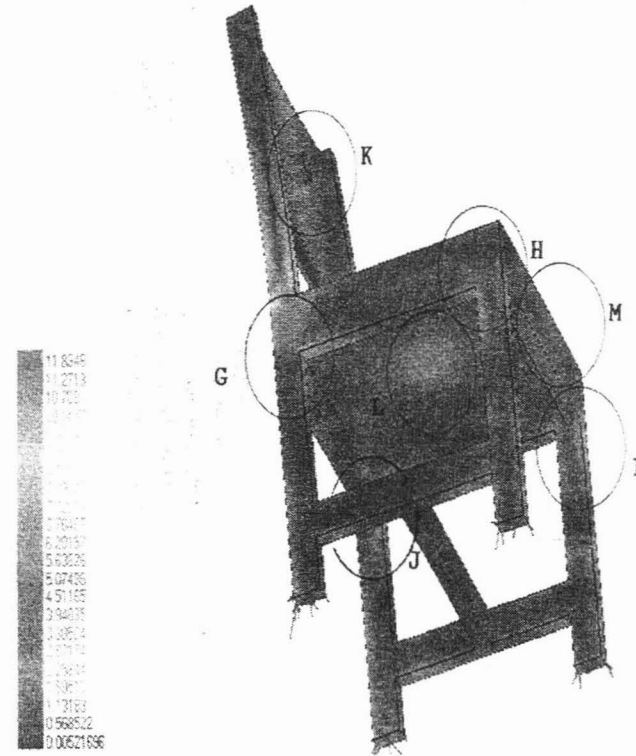

Note:  
Horizontal load : 760N  
Vertical Load : 1800N

Fig 12: Bottom isometric view of the modeled chair Von Mises stress contour