

**COMPARATIVE STUDY OF FUZZY LOGIC CONTROLLER
AND PROPORTIONAL INTEGRAL DERIVATIVE
CONTROLLER ON DC-DC BUCK CONVERTER**

This is presented in partial fulfilment for the award of the

Bachelor in Electrical Engineering (Hons)

UNIVERSITI TEKNOLOGI MARA (UTM)



MUHAMMAD JAMHURI BIN YUSOFF

FACULTY OF ELECTRICAL ENGINEERING

40450 SHAH ALAM, SELANGOR DARUL EHSAN

ACKNOWLEDGEMENTS

In the name of ALLAH, Most Generous and Most Merciful.

It is with the deepest sense of gratitude of the Almighty ALLAH who gives strength and ability to complete this thesis project. All good aspirations, devotions and prayers are due to ALLAH whose blessing and guidance have helped the author throughout to entire project.

The author would like to express a gratitude to his supervisor, Mr. Nik Fasdi Nik Ismail, for his support, belief, patience, fairness and for his feedback. The author would like to thank him for the opportunities and knowledge that he has given to the author over the year.

To the author's beloved father, mother, sister and brother, deepest thank you for your pray and always being supportive in whatever the author has done.

Sincere thank also goes to all the author's friends including everyone who helped the author directly and indirectly in completing this project.

ABSTRACT

The dc-dc converters are used to supply power to different system with highly efficient and have nonlinear behavior. The variations on the main parameter gave affected on the stability, thus desired amount of voltage couldn't be supply. As a solution, controller is added to the system in order to achieve a simple control circuit in regulating the output of the dc-dc converters. There are two strategies are used in this paper. First a knowledge based on fuzzy is studied and another control strategy is linear Proportional Integral Derivatives controller is applied. The main objective of this document is to compare the performance between Fuzzy Logic controller (FLC) and Proportional Integral Derivative controller (PIDC) in improving the performance of DC/DC Buck Converters. The evaluation of the output has been carried out and compared by software simulation using MATLAB Simulink. Fuzzy logic controller has been implemented to the system by developing fuzzy logic control algorithm. The signals will be processed based on the fuzzy logic rules-based and produce the output.

TABLE OF CONTENTS

ITEMS	PAGES
DECLARATION	ii
DEDICATION	iii
ACKNOWLEDGEMENTS	iv
ABSTRACT	vi
TABLE OF CONTENTS	vii
LIST OF FIGURES	ix
LIST OF TABLES	x
LIST OF SYMBOLS AND ABBREVIATIONS	x
ABBREVIATIONS	xi
CHAPTER 1: INTRODUCTION	1
1.1 Background of Study	1
1.2 Problem Statement	3
1.2.1 Problem Identification	3
1.2.2 Significant of Study	3
1.3 Research Objectives	3
1.4 Scope of Work	4
1.5 Thesis Organization	4
CHAPTER 2: LITERATURE REVIEW	5
2.1 Introduction	5
CHAPTER 3: THEORY AND MODELING	9
3.1 Introduction of Power Electronic Converter	9
3.2 DC-DC Buck Converter	11
3.2.1 Circuit Description	11
3.2.2 Basic Circuit Operation	13
3.3 Buck Topology	16
3.3.1 The Effect of Inductor Current	16
3.3.2 Continuous Conduction Mode	16
3.4 Switching Technique	21
3.4.1 Power Switching Diodes	21
3.4.2 Power MOSFET	22
3.4.3 Pulse-Width Modulation (PWM)	23
CHAPTER 4: METHODOLOGY	24
4.1 Introduction	24
4.1.1 Proportional Integral Derivative (PID) Controller	25
4.1.2 Fuzzy Logic Controller	28

CHAPTER 1

INTRODUCTION

1.1 BACKGROUND OF STUDY

Task of power electronics is to process and control the flow of electrical energy by supplying voltages and currents that suited for optimally load's user. Figure 1.1 shows a power electronic system block diagram. The output of power processor is as desired by load. Generally, the feedback controller compares the output of the power processor unit with reference value, and the error between this two is minimized by the controller [1].

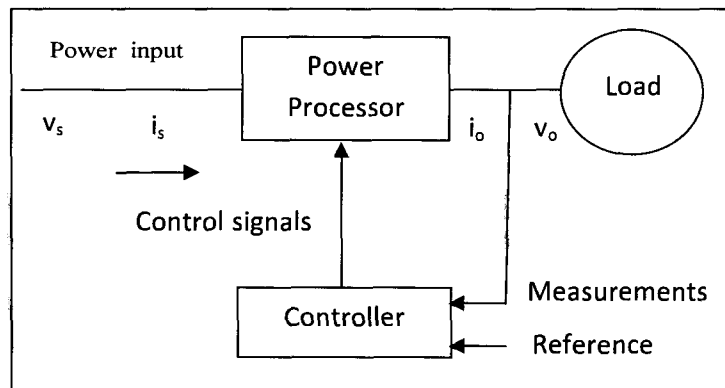

Figure 1.1: Block diagram of Power Electronic System

Power electronics are based on the switching of the power semiconductor devices. With the development of power semiconductor technology, the power handling capabilities and the switching speed of the power devices have improved tremendously [2]. The development on controller consists of linear