

# USEFULNESS AND APPLICATIONS OF ENTROPY MEASUREMENT

Muhamad Arif Hashim and Roshidi Din  
University Utara Malaysia, 06010, Sintok, Kedah

*Abstract:* Basically, entropy is a measure of uncertainty, a mathematical equation in defining the between certainty and uncertainty. Although the term has been around the world for a long time, there still lack in literature for better understanding of its usefulness and applications. In this paper, we mainly focus on the entropy by clarifying the real meaning of it in a simple and understandable mathematical way from a communication field point of view. The entropy properties and rules will be discussed in detail and we try to relate it with logarithm measure for a better understanding of entropy scenario. Some usefulness and applications of entropy in various fields such as communication, thermodynamic will be presented. We conclude this paper and state some challenges in applying entropy measurement. Hopefully, it will bring a new and better understanding of entropy not just to researcher and mathematician, but also to other related individual such as engineer and academician in applying this powerful measurement tool in their field.

Keywords: Entropy, Uncertainty, Application of entropy

## INTRODUCTION

Entropy is an average measurement of uncertainty. The term was borrowed from thermodynamics area which been used for measuring heat and perfectly applied in communication area and etc. The communication pioneer of entropy, Claude Shannon, in his paper, "A Mathematical Theory of Communication", had discussed and related the entropy to every sort of communication items. Entropy in the sense of communication is the average of information. It measures whether the information is reliable or not based on the level of uncertainty [7].

For instant, an entropy  $H(S)$  that would express the intuitive idea of the "average amount of information" contained in one symbol. The main observation about the entropy  $H(S)$  is that it depends only on the statistics of the source  $S$ . The corresponding unit is called a *bit*. Observe that if  $S$  has only two symbols, then

$$H(S) = \frac{1}{2} \log_2 2 + \frac{1}{2} \log_2 2 = 1 \text{ bit}$$

Thus, one bit is like the entropy of flipping an ideal coin once. There will be only two concrete results whether tail or head. The uncertainty of what will happen next, is entropy main dealing focus. Let say, we flip the coin but this time we flip it twice. The concrete results will increase due to the increasing level of uncertainty of what will happen from the first time flip till the second time flip. The result will be among 4 concrete results: head and head, head and tail, tail and head or tail and tail. The first time flip of coin is like binary bit case, it will be whether 0 bit or 1 bit. The sequence of first time flip and second time flip is similar to sequence of binary bit.

When entropy is adopted as measure of information, it does not include semantic and pragmatic aspects of information. But when it comes to deal with structural (syntactic) aspects of systems, it can be used for measuring the degree of constraint among variables of interest, thus comprising a powerful tool for dealing with systems problems such as systems modeling, analysis or design.

Assuming a communication system like Figure 1, where a message is intend to be transmitting. Entropy of the message basically will be high due to less information of the noise in the system and the entropy of the noise will be low. During the transmission process, the entropy of the message will slowly decrease when the real picture of the noise becoming clearly than before which then effect the entropy of the noise becoming high. This is the kind of reliable system that we want based on entropy measurement.

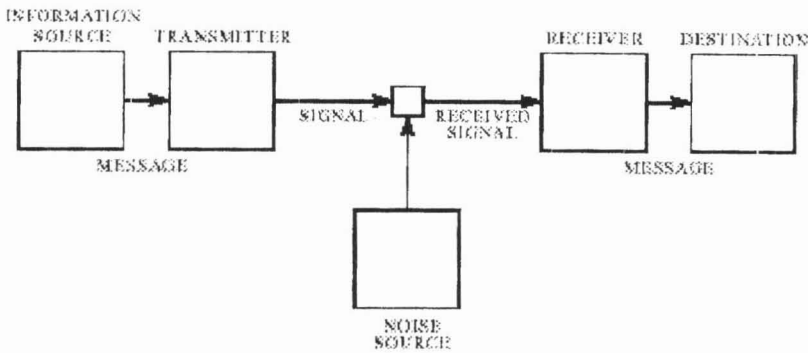

Figure 1: Schematic diagram of a general communication system [8]

It was based on second law of thermodynamic that is referring to law of physics with the consequence that, in a closed system, we can't finish any real physical process with as much useful energy as we had to start with. In other word, a part of the energy is always wasted which based on above situation it is the effect noise. Generally, the second law of thermodynamic states that work must be done to reduce the entropy of a system. In fact the over-all entropy of a system can never be reduced because if the entropy of a part the system is reduced, there will be a greater increase of the entropy in some other part. Some of the message will be lost which means there will never be full-received message. Further research had expanded the law to other area and described the law in three kinds of forms [2].

The first form states that no continually working heat engine can take heat from a source and convert it completely to work. For example, a ball fall from some height and the energy (heat) from the ball will not moves from the ball to its surrounding. If this true, the ball will continually bounce again and again without an end. While the second form indicates that heat cannot be transferred continually from one body to another at a higher temperature unless an external agent does the work. The last form express that the disorder (or entropy) of an isolated system can on stay the same or increase which suppose a ball is dropped from some height. It bounces a few times before coming to rest.

## DISCUSSIONS

### Property of Entropy

Ensuring that entropy measurement suits for measuring system is very important. It is why their properties must be defined so that, the system properties can be organized according to its specifications. Graph 1 shows the properties of entropy that can be categorized into four criteria (1). First, *positivity*, which means entropy, must be greater or equal to zero and it is always positive. It was compulsory property so that if  $H$  decreases, it only reaches until 0.  $H$  reaches 0, if and only if we certain with the outcome symbol result. Second, a small change in the source symbols causes only a small change in the entropy that describes the entropy function is a *continuous* function. Third, entropy must be *symmetry* for a change in the ordering of the source symbols does not change the entropy. Lastly, *coherence* which can be explain by the following example: The entropy of a source of symbols  $a_1$  and  $a_2$  can be computed from entropies of smaller sources. Suppose to read the message twice: the first time, it fail to distinguish between symbols  $a_1$  and  $a_2$ . Thus, if the reader read a  $p$ -times smaller message consisting of  $a_1$ 's (with probability  $\frac{p_1}{p}$ ) and  $a_2$ 's (with probability

$\frac{p_2}{p} = 1 - \frac{p_1}{p}$ ). The first reading gives us the entropy  $H(p, p_3, p_4, \dots, p_n)$  and the second one,

when a  $p$ -times smaller message is read, the entropy  $pH\left(\frac{p_1}{p}, \frac{p_2}{p}\right)$ . The two readings, then, gives the entropy of the original source:

$$H(p_1, p_2, p_3, \dots, p) = H(p_1 + p_2, p_3, \dots, p) + (p_1 + p_2)H\left(\frac{p_1}{p_1 + p_2}, \frac{p_2}{p_1 + p_2}\right) \text{ bits}$$

Graph 1: Entropy in the case of two possibilities with probabilities  $p$  and  $1 - p$ . [7].

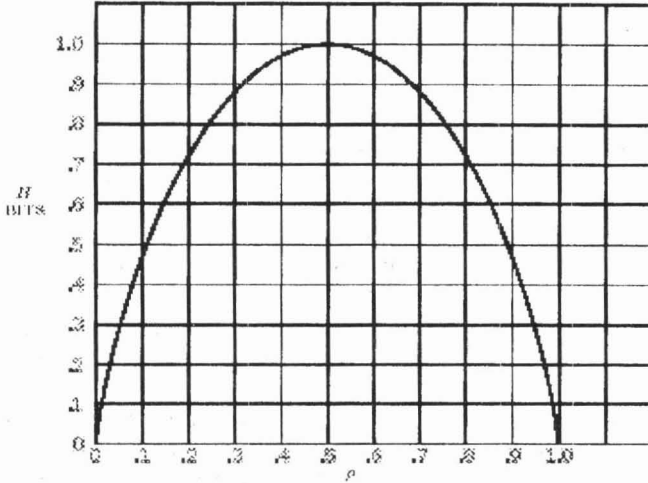

We continue on elaborating entropy by relate it with logarithm measure. Entropy uses logarithmic measure to suit in different conditions. Such as computation parameters that related to binary code, the usage of  $\log_2$  is perfectly can be well represent the two bits, 0 bit and 1 bit. Other parameters such as signal power, time domain etc., tend to vary linearly with the logarithm. For example, calculating signal power through Signal-to-Noise ratio (SNR). It changes  $\log_2$  to  $\log_{10}$  for translating the sequences of bits to decibels measure. By comparing the SNR result with time, we can observe the signal changes per time.

The flexibility of logarithm measure is also an advantage to be exploit. Many measurements had difficulty to adapt with other measurement from different area. Many of the limiting operations are simple in terms of the logarithm but would require restatement in terms of possibilities. But for logarithm, changing from bits for binary digit to decimal numbers (1 - 10) or from decimal numbers to sequence of 7 or 8 bits is not a problem (from  $\log_2$  to  $\log_{10}$  or from  $\log_{10}$  to  $\log_8$ ).

#### *Usefulness and Application of Entropy*

*Communication:* Entropy in communication is used to measure the reliability of a communication system. Figure 2 shows the scenario of entropy in general communication. The sender transmits the information as the input and transmission channel works as a road for sender to transmits it. At the end of the transmission channel, the receiver will receive the information as its output. There will be noise and equivocation in the transmission channel that may interrupts and will occur error in the output during the transmission. Good communication process is when information entropy tends to decrease on the way from the sender to the receiver, while noise entropy and equivocation entropy should be increase. Ways to maintain low entropy is by keeping the disturbance low using error control code [4] and by incorporating feedback from the receiver to the sender for assurance.

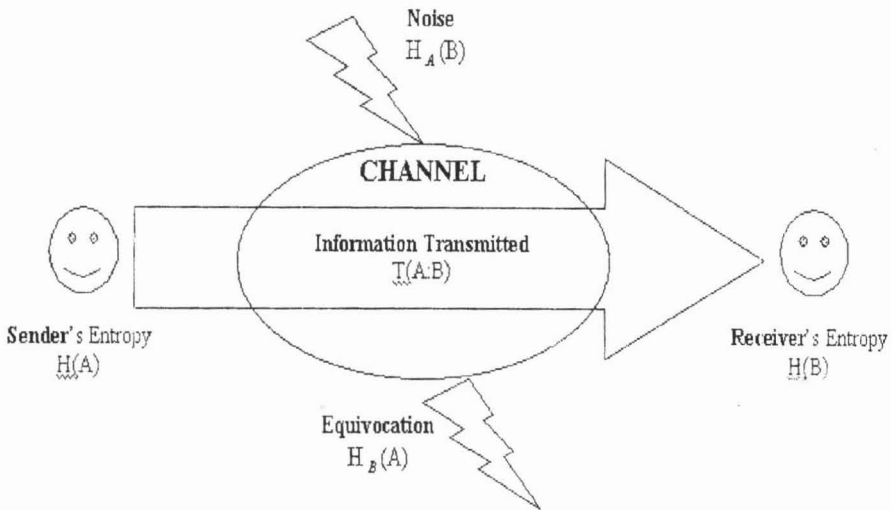

Figure 2: Relationship between sender, receiver, noise, equivocation and entropy [5]

**Thermodynamic:** In its broadest thermodynamic sense, entropy is a measure of disorder [2]. The use of entropy is to determine the fundamental of thermodynamics limit for a power system. Figure 3 shows a typical chip in a computation case. The power supply supplies the current for the chip to process and the wasted will return to the ground. As the information enters and leaves the chip, heat flows from the chip to a thermal reservoir [3]. In this case, the information and the information itself will be effect due to the heat that flows out. The distribution of the thermal (heat) will erase a bit of information per period. Based on the findings, nowadays, computer needs a good air-cooling system and low capacity of power usage to sustain and maximize its performance in order to counter this problem.

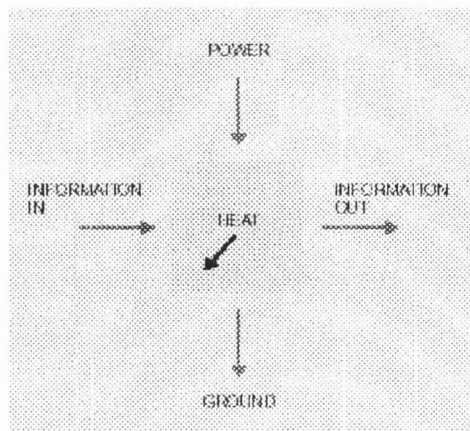

Figure 3: Fluxes into and out of a chip [3]

**Kinetic Energy:** Entropy measures the kinetic energy and uncertainty pattern of molecule's movement in kinetics area. As for an example, suppose that a vessel contains of  $n$  molecules of a gas: some of these molecules are moving with high velocity at any instant and others with very much lower velocities and the probability of any one molecule having an energy within any range is given by a probability density distribution which is the same for all molecules.

The entropy of this system is greater than that of a system in which the high-energy molecules are separated from the low energy ones and confine in different containers, although the energies of the two systems are the same. It is because of the uncertainty of the molecules movement is higher is the first system than the second system. The second system is more ordered in the sense that high and low energy molecules are separated instead of being all mixed together [6].

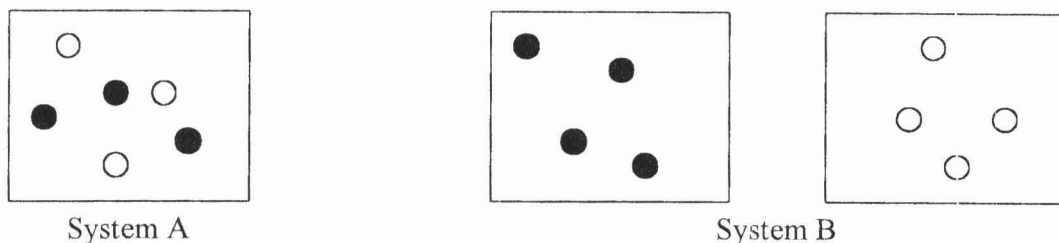

Figure 4: Molecule based on velocity level

## CONCLUSION

Entropy is a reliable measurement for uncertainty and information. The usage of entropy is widely in several kinds of areas including communication area and thermodynamic area. As presented, entropy usually been used to modeling a real or future system in form of mathematical figures. By using entropy measurement can solve a lot of problems and systems. Although it is reliable measure but it still cannot completely or fully mimic the real situation. Especially, in the case of linguistic measurement or emotion detection, a subjective kind of matter, it is difficult for entropy to model it if just based on the information. In other word, it opens several research opportunities. More research has to be done in utilizing entropy usage not just to explore its potential research in communication area but also in information, communication and technology (ICT) area. For example in security area, currently the issue of verification and recognition of speech or speaker not fully solve by using speech recognition system only. Such measurement is mainly intended to improve the performance and reliability of the system. Application of entropy in recognition system seems to be very promising in analyzing the effect of noise that occur and improving the reliability of the recognition result.

## REFERENCES

1. Adamek, J.1991. *Foundations of Coding : Theory and Applications of Error-Correcting Codes with Introduction to Cryptography and Information Theory*. John Wiley & Sons, Inc, Canada.
2. Chan Kee and Steven, L. 2002. Thermodynamics/Laws of thermodynamics. [Internet URL: <http://www.jcphysics.com/pdfs/thermolaw.pdf>].
3. Gershenfeld, N. 1996. Signal Entropy and the Thermodynamics of Computation. *IBM Systems Journal*, vol 35, NOS 3 & 4.
4. Hideki Imai. 1990. *Essentials of Error-Control Coding Techniques*. Academic Press, Inc, San Diego.
5. Krippendorff, K. 1986. *Information theory : Structural Models for Qualitative Data*, SAGE Publications Inc., Beverly Hills. California.
6. Leff, H. S. and Rex. A. F. 1990. *Maxwell's Demon: Entropy, Information, Computing*. Princeton University Press, Princeton.
7. Shannon, C. E. 1948. A Mathematical Theory of Communication. Reprinted with corrections from *The Bell System Technical Journal*, Vol. 27, pp. 379-423, 623-656.
8. Shannon, C. E. 1998. Communication in the Presence of Noise. *Proceedings OfThe IEEE*, vol. 86, NO. 2.