

# Characterization of a Magnetorheological Fluid Damper Applied to Semi-Active Engine Mounting System

*M. Hafiz Harun\**, Muhamad Azwar Azhari, R. Yunos  
Faculty of Engineering Technology, Universiti Teknikal Malaysia Melaka  
Hang Tuah Jaya, 76100 Durian Tunggal, Melaka, Malaysia.

A. K. Mat Yamin, M. Z. Sariman  
Faculty of Mechanical Engineering, Universiti Teknikal Malaysia Melaka  
Hang Tuah Jaya, 76100 Durian Tunggal, Melaka, Malaysia.

\*mohamadhafiz@utem.edu.my

## ABSTRACT

*This study is to propose a hysteresis damper model that can be integrated with the vehicle control system. A prototype of magnetorheological for engine mounting has been designed and tested to realize the objective of this study. The experimental on the prototype of the magnetorheological damper for engine mounts has been conducted in order to investigate the hysteresis of this damper. From the experiment, the results are evaluated in terms of damping force versus piston displacement and also the damping force versus piston velocity. It is significantly shows that the proposed model satisfy the non-linear hysteresis behavior of the MR damper in the form of force-velocity and force-displacement characteristics.*

**Keywords:** *Engine Mounts, Magnetorheological Damper, Hysteresis Behavior.*

## Introduction

In vehicle system, there is a engine mounting system which consists of engine, engine mounts and chassis. The engine mounting system uses to support engine weight and reduce engine vibration transmission to the chassis. The excitation forces generated by the engine produced the motion

of the engine block. There are two primary dynamic forces generated on the engine which involved gas pressure that is associated with combustion and expansion of the fuel-air mixture. Secondly it involved variable inertia associated with the reciprocating components within the engine. The variation of gas pressure in the engine during the combustion process yield the principal force of disturbance at low engine speeds, while the inertia forces may be considerably larger at higher speeds.

The engine mount can be categorized into passive, semi-active or active. Although active engine mounts are capable to produce good damping performance but producing a reliable active mount is difficult since it requires an actuator, adequate sealing, moving parts, and possibly large amount of energy for the actuator among other design issues. In semi-active mount, it's offer significant improvement over passive mount. Semi-active system benefit from the advantages of active system with the reliability of the passive system. Eventhough the control system fail to work, the semi-active mount can still work in the passive mode. Meanwhile, the power consumption of this system is very low, while it can change the characteristics to make different levels of resisting forces according to a low power commanding signal. These characteristics make the semi-active devices attractive in applications especillay when the reliability becomes the priority.

The semi active system work based on the feedback to minimize the vibration excitation. The vibration excitation known as disturbance is generated from the engine and being transferred to the body through the engine mount. The designated control system controls the appropriate damping force in the semi-active system to minimize the vibration. This process repeats continuously until the disturbance is transferred to the body accordingly and as desired from the system. Figure 1 shows a schematic of a semi-active vibration control.

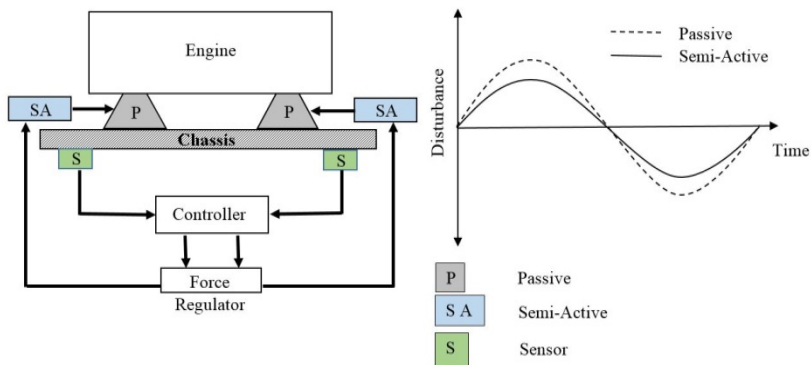

Figure 1: Schematic of a semi-active vibration control

Smart materials are substances with controllable properties capability that changes by external stimuli such as stress, temperature, pH, moisture, and electric or magnetic fields. Magnetorheology (MR) is a class of smart materials that are now being used in many applications mainly involving controlled products. Physical properties of magnetorheological material can be in form of fluids, gel or even a solid material such as elastomers. A magnetorheological fluid mainly consists of micron-sized iron particle that is suspended in a carrier oil [1]. When exposed to the external magnetic field, MR fluid has an ability of changing from free-flowing liquid state into a semi-solid state with restricted fluid movement in fast response within several milliseconds. The advantages of MR fluids lead to the development of MR based device in a wide range application such as in medical sectors, automotive sectors and civil sectors [2,3].

Beside MR fluid there is also another smart material that has the same operating concept namely electrorheological (ER) fluid. The comparison of the performance of ER fluid and MR fluid had been discussed by many publications [1,4,5]. However this study focused on application the MR fluids for semi active engine mounts because of its ability to stand 50-100 Kpa of yield stress and higher density of  $0.1 \text{ J/cm}^3$  [6]. Since the ERF and MRF have characteristics to change their properties from soft to hard and hard to soft therefore it was well-known as the vibration isolator devices [7][8]. For the automotive sectors, most application of MRF on the suspension system is known as MR damper [9,10,11]. Besides that, MR application for rotary damper such as MR brake had been used widely since a long time ago [12,13]. There are also other applications of MR mount isolator which had been used on DVD or CD player on vehicles [14].

This paper organized with introduction on semi active MR fluids damper and review of the previous works on related field in the first section. Section 2 introduces the MR damper work principle and operation. The experimental procedure to obtain the behavior of MR damper in form of force-velocity and force-displacement characteristics is presented in section 3. Finally, the last section presents the conclusion of this study.

### **MR Damper Work Principle**

In order to achieve the objective of this study a prototype of an MR damper for engine mounts has been fabricated at Faculty of Mechanical Engineering, Universiti Teknikal Malaysia Melaka (UTeM). A schematic of MR engine mounting design is shown Figure 2.

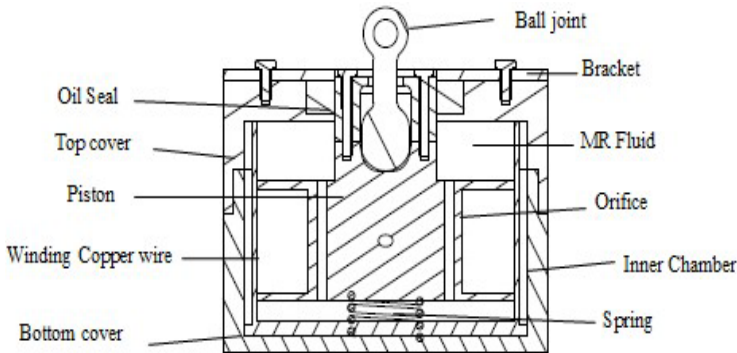

Figure 2: Schematic of MR engine mounting design

The MR engine mount design consists of a four orifices, wire coil, piston, piston rod, inner chamber, oil seals upper cover, bottom cover, bracket, ball joint and MR fluid. The chamber is the work space for piston passing through the MR fluids. The top and bottom cover work to prevent the MR fluid flowing out from the inner chamber. Meanwhile oil seals were used at the moving piston area to prevent the MR fluid flow out. Mounting bracket was designed on the bottom cover to mount it with vehicle body. In addition, spring is used to support the static and dynamic load from the engine.

The ball joint located on top of the engine mount is used as the main component and responsible to transfer forces from the engine to the piston in one direction. It moves linearly during compression and extension motion. The socket connected to the piston provides free work space for the ball joint to move. Four orifices holes with 3 mm diameter was drilled on the piston to allow the MR fluid pass through. In addition, copper wires were coiled around the piston to generate magnetic field when current is supplied. The total amount of winding wires wrapped around the circumference of the piston is 1200. This is the maximum wire circumference that can be produced based on the design of the wire coil space on the piston. The circumference had been insulated with araldite to avoid electrical leakage between MR fluids and the winding cooper wire. The maximum stroke produced by MR engine mount is 10 mm while the maximum current to the electromagnet in the magnetic choke is 1.0 Ampere and the coil resistance is 25 Ohm.

The MR damper operating principle is based on conventional hydraulic damper. However the convensional hydraulic damper uses oil while MR damper uses MR fluids and winding copper. The advantage of hydraulic damper is capable of controlling the damping force compared to rubber mount where the stiffness and damping of the damper is fixed.

The MR damper operates based on flow mode. When the MR fluids passes through the orifices, it exposed to the magnetic field. The characteristic of MR fluids viscosity changes from linear viscous to semi-solid in milliseconds when exposed to magnetic field. Increasing of the MR fluids viscosity causing in flow resistance in the orifices thus damping force also increases. The flow mode of operation in MR damper is as depicted in Figure 3.

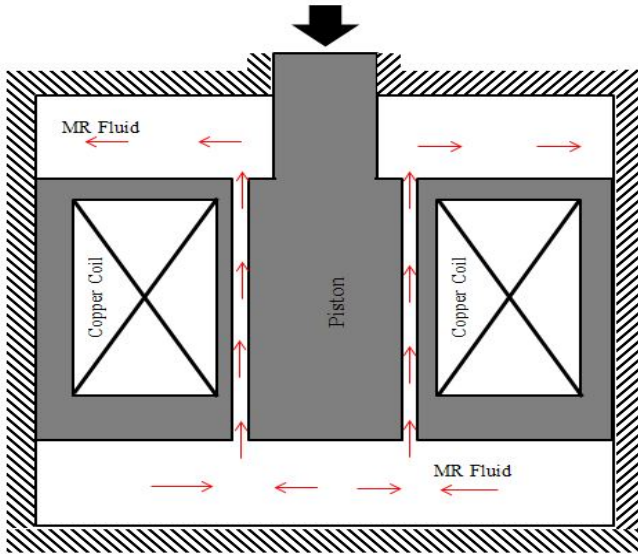

Figure 3: Flow modes of operation in MR damper

The resisting force to motion of the MR damper increases or decreases in a non-linear fashion can be performed by adjusting the magnetic strength within allowable range. It is realized when the magnetic strength was controlled by the current passing through the winding copper coil. Therefore, the position of the winding copper coil located closely to the orifices so that the magnetic field concentrations focus on the orifice area in order to increase the effectiveness of the damper when exposed to current.

Since the maximum current supplied to this MR engine mount is 1.0 Ampere, the maximum magnetic field generated was 0.024 Tesla determined using Finite Element Method Magnetic (FEMM) software as shown in Figure 4 and Figure 5. The same method commonly used by other researcher on this area [15][16].

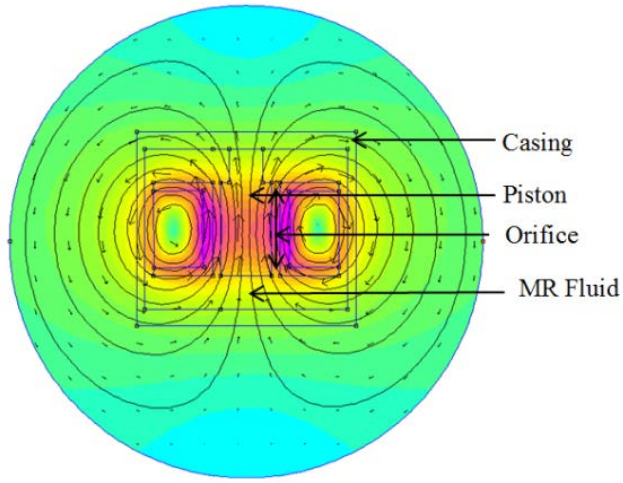

Figure 4: Prediction of magnetic field of MR damper

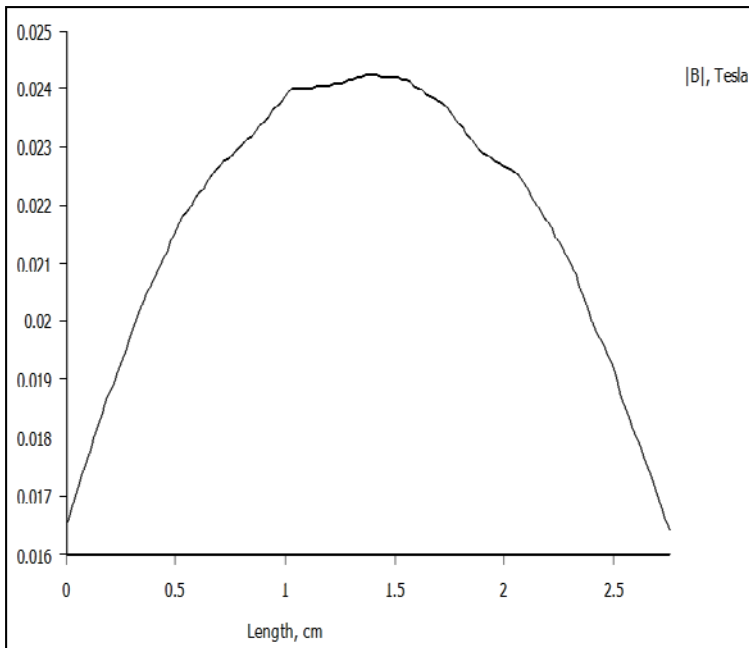

Figure 5: Magnetic field along the orifice

## **Experimental**

A MR damper is one of the most damping devices, where the magnitude of the resisting force upon a mechanical structure can be adjusted in real time. The magnitude of resisting force can be adjusted by altering the amount of current passing through wires fixed in the damper. The MR damper characteristics have been studied through both numerical simulation and laboratory tests. To evaluate the benefits of MR dampers in vibration control applications, it is necessary to develop a model that can accurately describe the behavior of the MR damper. Both parametric and non-parametric models have been developed to indicate the behavior of the MR. A non-parametric model has been developed where it is precisely described the response of MR damper to cyclic and random excitations for both constant and variable magnetic field [17][18].

The MR damper inner chamber is filled with MR fluid which is known as one of the controllable type fluids. MR fluid contains dispersed micron sized magnetically polarizable particles which allow the fluids change the behavior from linear viscous to semi-solid in milliseconds when exposed to magnetic field. By adjusting the magnetic strength within allowable range, the resisting force to motion of the MR damper increase or decrease in a non-linear trend. In this works, the magnetic strength controlled by the current pass through the winding copper coil.

Since the proposed damper model depends on the availability of experimental data, the experimental investigation of force-velocity and force-displacement characteristics of the MR damper needs to be tested. Experiment was conducted to obtain the data for identification of the proposed MR damper model. Based on the experimental data, a modelling method of the MR damper was satisfied by using a sixth order polynomial equation.

The experimental work was conducted in the Faculty of Mechanical Engineering, Universiti Teknikal Malaysia Melaka (UTeM) using a shock absorber test machine. Two types of sensors were used in this experiment which is Linear Variable Displacement Transducer (LVDT) to measure the displacement and relative velocity of the damper while the Load Cell sensor to measure the damper force [18]. The National Instrument (NI) Card device provides signal processing of the transducers and excitation signals of the slider crank actuator system. These signals are digitally processed and stored in a personal computer using MATLAB Simulink. Control signals to the MR damper are converted to analogue signals by NI card device. Then, the voltage signals are passed through current driver and sent to the MR damper. The configuration of the shock absorber test machine is as shown in Figure 6.

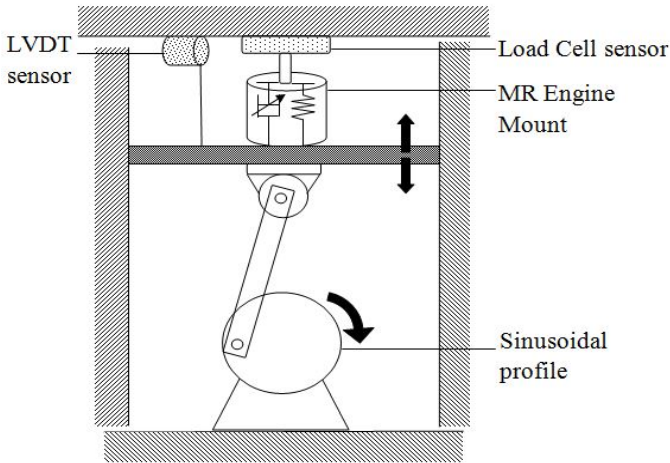

Figure 6: Schematic diagram for experimental setup for identification purposed of MR damper model

The MR damper testing was conducted by applying a cyclic motion between the upper and lower ends of the MR damper for different values of applied currents to the dampers coils. The response of the MR damper due to 0.22 Hz sinusoidal excitation with amplitude of 10 mm was investigated for five constant currents of 0.2, 0.4, 0.6, 0.8, and 1.0 Ampere. The measured force in time domain, the force-velocity characteristics and the force-displacement are shown in Figure 7, 8 and 9 respectively.

## Results and Discussion

Figure 7 shows the harmonic motion graph which is the results due to the movement of the piston. The increasing of force in each different current is resulted from the generated magnetic field increase as the current increases. The increasing magnetic field leads to the increasing of the viscosity of MR damper. Therefore, high viscosity generates large resistance force from passing through the orifice, resulting the high damping force generated. Figure 8 depicts the force-velocity graph which indicates the characteristics of the force generated at certain velocity of the piston. The velocity of the piston is integrated from the displacement of the piston travel. As the velocity increases, the force increases until reaches the constant velocity which is 0.8 mm/s. The negative and positive value shows the movement of the piston up and down respectively.



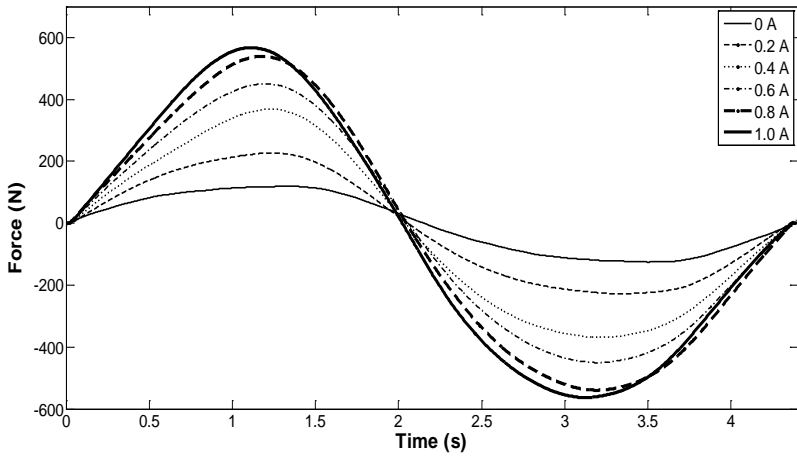

Figure 7: Measured forces for five constant current levels

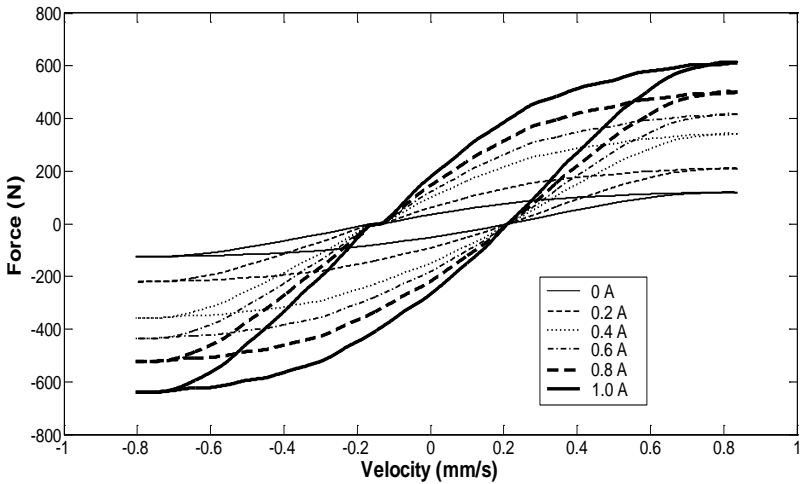

Figure 8: Force-velocity characteristic for five constant current levels

Figure 9 shows the force-displacement graph which indicates the characteristic of the force at certain displacement of the piston travel. The stroke of the piston is 5 mm upward and 5mm downward. As the piston travel start at -5mm then push upward until reaches maximum displacement then moving pulling down. Based on the results, it clearly shows that the magnitude of the damping force at the piston velocity and displacement

increases proportionally with the increase of the current applied to the winding cooper coil on the damper.

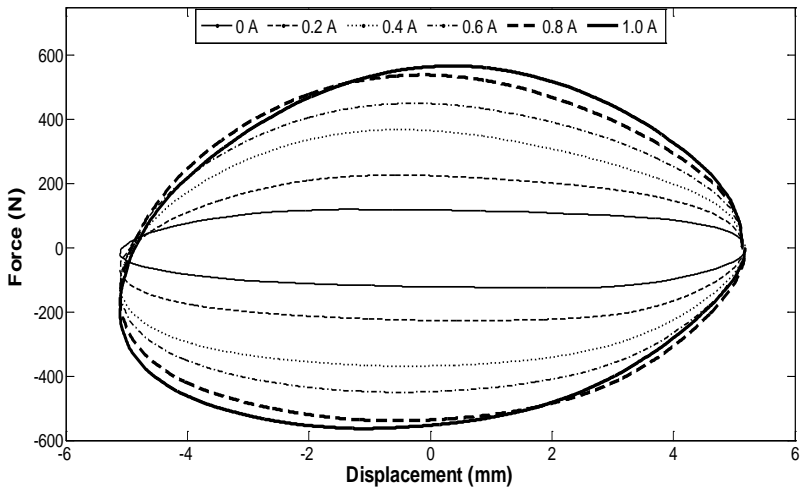

Figure 9: Force-displacement characteristic for five constant current levels

## Conclusion

In this study, the hysteresis behavior of the MR damper has been observed and investigated. The experimental data involved damping force was compared with the proposed model. Indeed it has been verified that the proposed model satisfy the non-linear hysteresis behavior of the MR damper in the form of force-velocity and force-displacement characteristics.

## Acknowledgement

The author would like to acknowledge the Malaysian Ministry of Higher Education [FRGS/2/2014/TK01/FKM/02/F00231] and Universiti Teknikal Malaysia Melaka for the support and funding throughout this study.

## References

- [1] M.R. Jolly, J.W. Bender and J.D. Carlson, "Properties and Applications of Commercial Magnetorheological Fluids," *Journal of Intelligent Material Systems and Structures*, 10, 5-13. (1999).
- [2] A.M. Aly, "Vibration Control of Buildings Using Magnetorheological Damper: A New Control Algorithm," *Journal of Engineering*, 10. (2013).
- [3] H. Suojun, S. Wenku, W. Shaohua and W. Xuejing, "Buiding model and dynamic characteristic analysis for magnetorheological fluid engine mount," *Electronic and Mechanical Engineering and Information Technology (EMEIT)*, 2011 International Conference, 2152-2154. (2011).
- [4] K.D. Weiss, T.G. Duclos, J.D. Carlson, M.J. Chrzan and A.J. Margida, "High Strength Magneto- and Electro-rheological Fluids," *SAE Technical Paper 932451*, 8. (1993).
- [5] A.K. El Wahed, J.L. Sproston and G.K. Schleyer, "Electrorheological and magnetorheological fluids in blast resistant design applications," *Materials & Design*, 23, 391-404. (2002).
- [6] A.S.M.S. Islam and A.K.W. Ahmed, "A Comparative Study of Advanced Suspension Dampers for Vibration and Shock Isolation Performance of Road Vehicle," *SAE Technical Paper 2006-01-0484*. 12. (2006).
- [7] S.R. Hong, S.B. Choi, W.J. Jung and W.B. Jeong, "Vibration Isolation of Structural Systems Using Squeeze Mode ER Mounts," *Journal of Intelligent Material Systems and Structures*, 13, 421-424. (2002b).
- [8] S.B. Choi and H.J. Song, "Vibration control of a passenger vehicle utilizing a semi-active ER engine mount," *Vehicle System Dynamics*, 37, 193-216. (2002).
- [9] X. Zhang, W. Li and Y. Zhou, "A variable stiffness MR damper for vibration suppression," 106-111. (2009).
- [10] J. Bajkowski, J. Nachman, M. Shillor and M. Sofonea, "A model for a magnetorheological damper," *Mathematical and Computer Modelling*, 48, 56-68. (2008).
- [11] W. En Rong, M. Xiao Qing, S. Rakheja and C.Y. Su, "Semi-active control of vehicle vibration with MR-dampers. Decision and Control," *Proceedings. 42nd IEEE Conference*, 3, 2270-2275. (2003).
- [12] J.H. Lee, C. Han, D. Ahn, J.K. Lee, S.H. Park and S. Park, "Design and Performance Evaluation of a Rotary Magnetorheological Damper for Unmanned Vehicle Suspension Systems," *The Scientific World Journal*, 10. (2013).

- [13] F. Imaduddin, S.A. Mazlan and H. Zamzuri, "A design and modelling review of rotary magnetorheological damper," *Materials & Design*, 51, 575-591. (2013).
- [14] Y.K. Ahn, B.S. Yang, M. Ahmadian and S. Morishita, "A Small-sized Variable-damping Mount using Magnetorheological Fluid," *Journal Of Intelligent Material Systems And Structures*, Vol. 16, pp.127-133. (2005b).
- [15] M.Y. Salloom and Z. Samad, "Design and modeling magnetorheological directional control valve," *Journal of Intelligent Material Systems and Structures*, 23, 155-167. (2012).
- [16] I.I.M. Yazid, S.A. Mazlan, T. Kikuchi, H. Zamzuri and F. Imaduddin, "Design of Magnetorheological Damper With a Combination of Shear and Squeeze Modes," *Materials & Design*, 54, 87-95. (2014).
- [17] B.F. Spencer, S.J. Dyke, M.K. Sain and J.D. Carlson, "Phenomenological Model for Magnetorheological Dampers," *Journal of Engineering Mechanics*, 123(3), 230-238. (1997).
- [18] M.R.M Yunos, M.H. Harun, M.Z. Sariman and A.K.M. Yamin, "Development of Magnetorheological Engine Mount Test Rig," *MATEC Web of Conferences*, 97, 01072. (2017).