

**UNIVERSITI TEKNOLOGI MARA**

**SIMULATION AND FAILURE  
ANALYSIS OF FIBRE-REINFORCED  
COMPOSITE LAMINATES UNDER  
VARIOUS LOAD AND BOUNDARY  
CONDITIONS**

**MOHAMAD BIN MALI**

Thesis submitted in fulfilment  
of the requirements for the degree of  
**Master of Science**

**Faculty of Mechanical Engineering**

December 2017

## ABSTRACT

Composite materials are desired in modern structures due to its various advantages. Nevertheless, the application of composites in structures is still limited by the difficulty in predicting their failure behaviour. Conventionally, predicting failure behaviour procedures involve with physical tests, which are expensive and tedious. Due to that, analytical method and simulation to predict experiment result are introduced. Nevertheless, to date, there is still lack of research related to finite element modelling and simulation to predict the failure behaviour of composite laminates under various load and boundary conditions. Moreover, no attempt has been done to simulate the failure behaviour of composite laminates under transverse sinusoidal loading and various boundary conditions using commercial software. Therefore, this study aims to simulate the deformation and failure behaviour of fibre-reinforced linear elastic, orthotropic, homogenous and unidirectional composite laminates under transverse sinusoidal loading and various boundary conditions using commercial software. The work has been organised according to four case studies, progressing from investigating the failure behaviour of composite laminates with ply orientation  $[\theta_4/0_4/\theta_4]_s$  under uniaxial load; composite laminates with ply orientation  $[0/0]_s$  &  $[90/90]_s$ ,  $[+45/-45]_s$  and  $[0/90]_s$  under biaxial load; and to finally, composite laminates with ply orientation  $[0/90/90/0]$  under transverse sinusoidal load. In all cases, generally, convergence analysis and numerical validations were carried out first. For analytical approach, a MATLAB programme was written to compute the displacements, strains and stresses of the laminates based on the First Order Shear Deformation Theory (FSDT) under selected load and boundary conditions; as similar to ANSYS. For failure analysis, Maximum Stress and Tsai-Wu Failure criteria were employed to determine the failure loads. Failure curves for all four cases are plotted and each failure behaviour was analysed. In general, all the finite element models have been proved to be valid. Comparing the simulation and analytical approaches, the results (displacements, stresses and failure loads) for uniaxial and biaxial load are found close to each other, by maximum difference of 2%. For transverse sinusoidal load, the current finite element model is found to be accurate for simulating a thin and moderately thick laminate (aspect ratio;  $S > 10$ ). The study has proved that the FE models are accurate and thus conforming that the results obtained using the FE commercial software (ANSYS) are valid. It also proves that the integration between FE simulation and analytical approaches can become an effective tool in investigating the failure behaviour of composite laminates. This study has contributed significantly to enhancing knowledge about the failure behaviour of fibre-reinforced composite laminates under various load and boundary conditions using commercial finite element software, ANSYS and analytical computation based on the mechanic of composite materials. This study is novel as to date, no study investigating the effects of boundary conditions to the failure behaviour of composite laminates has been reported.

## ACKNOWLEDGEMENTS

First and foremost, all the praise go to Allah s.w.t for His blessings that I am able to embark on my MSc study; and by His Will I am able to complete this long and challenging journey successfully.

My sincere gratitude and thanks go to my main supervisor, Assoc Prof Ir Dr. Jamaluddin bin Mahmud and my co-supervisor Dr Mohd Nor Azmi bin Ab Patar. Thank you for the support, patience and ideas in assisting me with this research.

A special thanks to my colleagues and friends for helping me with this research. I would also like to acknowledge my sincere gratitude to every individual who has directly or indirectly contributed towards the completion of my work and thesis.

I am indebted to my beloved brothers and sisters especially to Zairulliatti binti Mali, Zahida binti Mali, her husband Shaheezam bin Sabaruddin, and family for their support and sacrifice throughout my life.

Finally, this thesis is specially dedicated to the loving memory of my very dear late father, Mali Bin Abdul Majid and mother, Zawyah Binti Mahammad Nadzri for the vision, sacrifice and determination to nurture me. Only Allah could repay you for everything. This piece of victory is dedicated to both of you. Alhamdulillah.

# TABLE OF CONTENTS

	Page
<b>CONFIRMATION BY PANEL OF EXAMINERS</b>	ii
<b>AUTHOR'S DECLARATION</b>	iii
<b>ABSTRACT</b>	iv
<b>ACKNOWLEDGEMENT</b>	v
<b>TABLE OF CONTENTS</b>	vi
<b>LIST OF TABLES</b>	ix
<b>LIST OF FIGURES</b>	xi
<b>LIST OF SYMBOLS</b>	xiv
<b>LIST OF ABBREVIATIONS</b>	xv
<b>CHAPTER ONE: INTRODUCTION</b>	1
1.1 Background of Study	1
1.2 Problem Statements	3
1.3 Research Objective	4
1.4 Scope of Research	4
1.5 Significance of Research	5
1.6 Thesis Outline	6
<b>CHAPTER TWO: LITERATURE REVIEW</b>	7
2.1 Overview	7
2.2 Macromechanical Behaviour of Lamina	7
2.2.1 Classical Lamination Theory (CLT)	7
2.2.2 First Order Shear Deformation Theory (FSDT)	10
2.2.3 Failure Criteria for Composite Laminate	12
2.2.3.1 Maximum Stress Criterion	12
2.2.3.2 Tsai-Wu Failure Criterion	13
2.2.3.3 Tsai-Hill Failure Criterion	14
2.2.3.4 Hoffman Failure Criterion	15
2.3 Analytical Approach for Composite Laminate Failure Analysis	15
2.4 Limitation on Experimental Method	16
2.5 Numerical Analysis of Composite Materials Using FE Simulation Software	17

# CHAPTER ONE

## INTRODUCTION

### 1.1 BACKGROUND OF STUDY

Composite material is a resulting material from the combination of two or more materials on a macroscopic scale or a scale that can be identified by the naked eyes, to form a useful third material. This new useful third material, if well designed, will usually exhibit the best qualities of their combined components or constituents and often has some qualities that neither constituent possesses (Jones, 1999).

Laminated composite materials or composite laminates consists of layers of at least two different material that are bonded together. Figure 1.1 illustrates the example of laminate construction in a composite laminate. Due to variation of fibre directions, the stiffness and strength-to-failure of composite laminate become different in different directions. This makes the properties of composite laminates to be tailorable, but making these materials inherently anisotropic. Furthermore, its failure is characterised by many failure modes such as matrix breakage and fibre failure (Pietropaoli, 2012).

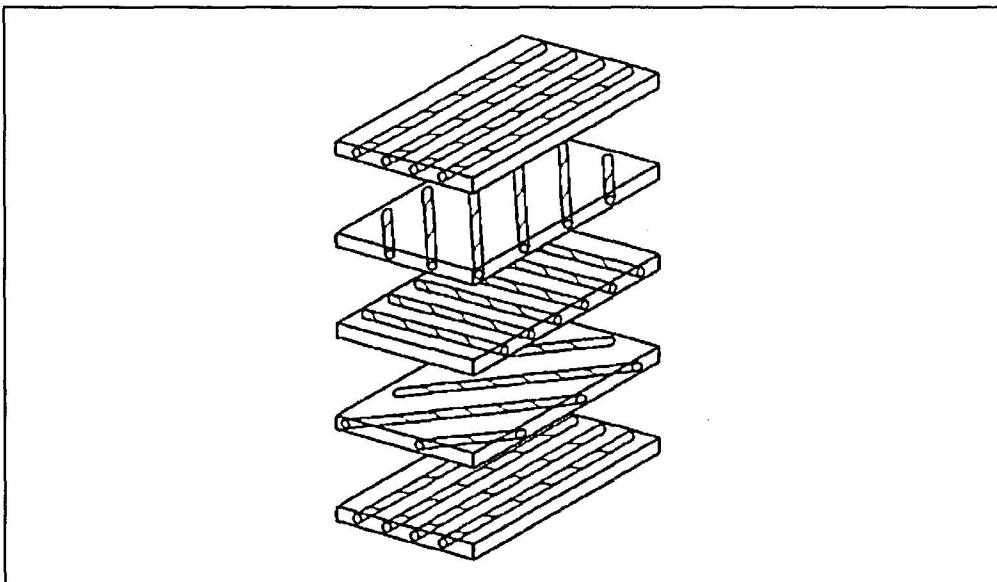

*Figure 1.1: Example exploded view of laminate construction (Jones, 1999)*