



CREATIONS de UiTM

INTERNATIONAL MEGA INNOVATION CARNIVAL 2024

Navigating Innovation and Seizing Global Fortune

CHANGE THE WORLD THROUGH INNOVATION

e-PROCEEDING

27th APRIL 2024

UNIVERSITI TEKNOLOGI MARA
CAWANGAN SELANGOR, KAMPUS DENGKIL
MALAYSIA

ORGANISED BY:



Pusat
Asasi

Compact Hydro Vertical axis Blade Turbine

Mohamad Idham Ishak, *Ainaa Maya Munira Ismail and Najibah Ab Latif

Mechanical Engineering Studies, College of Engineering, Universiti Teknologi MARA
Johor Branch, Pasir Gudang Campus, 81750 Masai,
Bandar Seri Alam, Johor Darul Ta'zim, Malaysia

*Corresponding author: ainaa7609@uitm.edu.my

ABSTRACT

To develop sustainable alternatives to conventional energy production methods, the importance of renewable energy sources is increasing. Hydropower is a renewable energy source that harnesses the kinetic energy of moving water to generate electricity. In many cases, small-scale hydropower facilities are more feasible and cost-effective than large-scale ones. Hydro turbines are not extensively utilized in Malaysia for the generation of power. Therefore, a compact hydro turbine can be used to provide electricity for communication devices or electrical appliances. This study aims to create a compact hydro turbine power generator employing vertical axis turbine blades that may be applied in many locations, including distant regions. This prototype is well developed by efficient utilization of various production processes, such as machining, sheet metal fabrication, joining techniques, and other mechanical method. With a maximum power of 2 kW, the intended result of providing electricity and facilitating the user's daily tasks using renewable energy was achieved.

Keywords: hydropower; compact hydro turbine; vertical axis turbine blade; renewable energy; electricity.

1. INTRODUCTION

Amidst the global desire for sustainable alternatives to conventional energy production, renewable energy sources are gaining increasing importance. Energy demand in Malaysia is expected to increase. Lifestyle modernization has driven up Malaysia's energy demand by 4.8% over the past decade, and it's expected to exceed 150,000 GVh by 2030 (Hazmin et al., 2024). In the event of a natural disaster causing a disruption in the energy supply, a small-scale or compact hydro turbine can be utilized to provide power for emergency communication devices. This prototype design is highly influenced by the hydrodynamics of the natural water resources, notably rivers. Hence, it is important to understand the river flow dynamics, especially when climate factors like wet and dry seasons greatly affect river hydrodynamics (Gasim et al., 2013). With only a modest amount of electricity required, a small-scale hydro turbine might be a useful tool for producing power (Raman et al., 2009). The utilization of electrical equipment in an area lacking an electrical source is prohibited. For example, when venturing to a remote area, our only power options can be additional batteries or a power bank, which will be insufficient to continue using electronic devices. Moreover, individuals who choose to vacation at a beach or in a mountainous region may encounter difficulties when attempting to recharge their electrical devices (Supardi et al., 2021). The primary objective of this project is to develop a compact hydro turbine power generator that employs vertical wind turbine blades. The purpose is to enhance the efficiency and power output of the system by using sophisticated design and control

approaches. The prototype will be positioned at water sources such as rivers or waterfalls. The water will pass through the blade, and the mechanical energy that propels the generator shaft transforms electrical energy (Rusianto et al., 2023). The torque and nominal speed are the mechanical outputs of the rotor that influence the load and speed of the generator. The product is designed for use in distant and off-grid places. The integration of vertical wind turbine blades with a compact hydro concept can enhance the overall efficiency and power output of the system. Vertical wind turbines are distinguished by their capacity to function in turbulent wind conditions and at lower wind velocities, in contrast to horizontal axis turbines. Vertical wind turbines are affordable, easy to navigate, and can deal with 360° wind (Syahin et al., 2024). The concept involves maximizing space use by integrating a compact hydro turbine with vertical wind turbine blades, making it suitable for installations with restricted space.

2. METHODOLOGY

2.1. Modelling

Modelling was designed by using Solidwork Software and converted into part by part. Then, the part was combined into the design as illustrated in **Figure 1**.

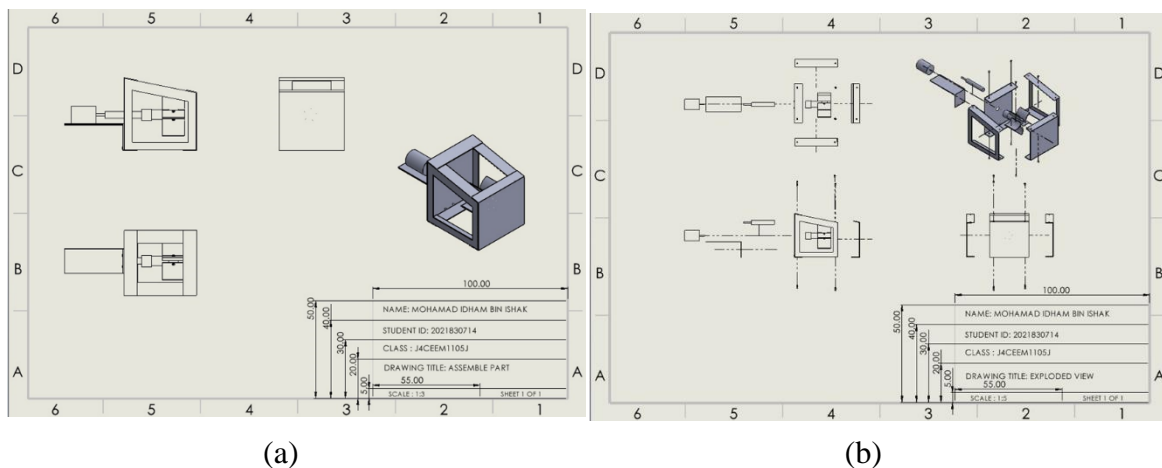

Figure 1. (a) Assemble part (b) Explode View

The aluminium plate was marked with an appropriate length. After marking, the cutting procedure begins with the aluminium plate and the PVC pipe. The best choice for cutting aluminium is to utilise a sheet metal shear. Next, use a saw to cut the PVC pipe. The next step is grinding. This procedure is used to smooth the sidewalls after cutting. Grinding was also used to remove any excess or undesired steel or PVC from the previously cut plate and PVC pipe. Following that, the drilling process is initiated. This technique is carried out following the cutting process. This technique creates many holes in the case, blade, and blade shaft. The last step is assembly. This technique involves screwing together the blade, casing, and casing shaft. The prototype is built with durability in mind, as is the surface on which the product will be installed. It consists of numerous pieces, including a case, blade, shaft, and holder. The water will flow to the left of the design, causing the blade to rotate. The spinning will generate sufficient power to charge or supply any modest design. The final product as shown in Figure 2.



Figure 2. Side view of Compact Hydro Vertical axis Blade Turbine

2.2. Functionality of Prototype

Designed to offer a convenient way for consumers to charge their electronic gadgets with renewable energy sources, the compact hydro turbine powers generator is a vertical wind turbine blade. The lightweight of the compact hydro turbine enables it to be portable and simple to install in a variety of water sources, including rivers, streams, and waterfall regions. The compact hydro turbine is simple to operate, and it starts to function when submerged in water that has enough flow. The compact turbine is enclosed in a casing for added durability. The casing's ability to contain and safeguard the small turbine supports the compact hydro turbine. The blade, which is the following component, is an essential part of this turbine. The generator produces energy as the water passes through the turbine and rotates the turbine blades.

This prototype is also fabricated with a suitable and modular design for straightforward maintenance. With an emphasis on affordability, sustainability, and user education, this prototype employed a vertical wind turbine blade power generator that aims to empower people to harness clean energy for their charging needs, fostering a greener and more accessible approach to personal device power.

3. RESULTS AND DISCUSSION

Sustainability is the ability to maintain a balance between economic, social, and environmental factors to meet the needs of the present without compromising the ability of future generations to meet their own needs. The sustainability of compact hydro turbines using vertical wind blade design encompasses various environmental, social, and economic considerations throughout their life cycle. The compact hydro turbine using vertical wind blade design harness the power of flowing water to generate electricity, making them a renewable energy source. Unlike fossil fuels, which are finite and contribute to climate change, the energy produced by compact hydro turbines comes from the natural water cycle, ensuring a sustainable and continuous power supply. As presented in **Figure 3**, power increases in direct proportion to velocity.

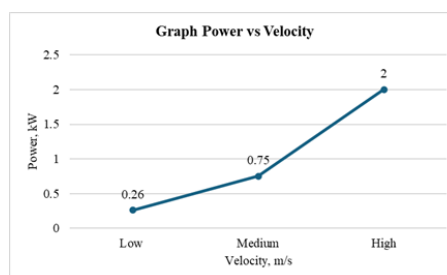

Figure 3. Graph Power (kW) vs Velocity (m/s)

Next, compact hydro turbines using vertical wind blades are generally installed in rivers, streams, or other water sources with a consistent flow. The work by converting the kinetic energy of the moving water into mechanical energy, which is then used to rotate a turbine and generate electricity. Micro hydro turbines are an environmentally friendly and sustainable energy solution, as they do not produce any greenhouse gas emissions and rely on renewable resources. They are particularly suitable for remote areas or off-grid locations where access to electricity is limited.

4. CONCLUSION

In conclusion, the compact hydro turbine using a vertical wind turbine blade power generator stands as a groundbreaking and accessible solution for harnessing renewable energy. With its compact and lightweight design, people can effortlessly bring this compact turbine everywhere, tapping into the power of flowing water to charge any electronic device. This user-friendly feature including its component, blade design, and casing, makes it an ideal companion for outdoor enthusiasts, adventurers, or those residing in off-grid areas. The compact hydro turbine is known as a turbine that generates power from renewable energy. It represents a step toward a future where clean energy is not only accessible but seamlessly integrated into our daily lives, offering a portable and eco-friendly alternative for people everywhere.

ACKNOWLEDGEMENT

The author wishes to begin by expressing sincere appreciation to all individuals who assisted in the completion of the undertaking. His esteemed supervisor, Ts. Ainaa Maya Munira binti Ismail, merits particular recognition for her resolute guidance and perceptive evaluation, both of which significantly impacted the trajectory of the project. Thank you to the writer's family members for their encouragement and support throughout the course of this endeavor. Furthermore, UiTM deserves special recognition for supplying the necessary facilities and equipment for the development and culmination of this effort.

REFERENCES

- Gasim, M. B., Toriman, M. E., Idris, M., Lun, P. I., Kamarudin, M. K. A., Nor Azlina, A. A., Mokhtar, M., & Mastura, S. A. S. (2013). River flow conditions and dynamic state analysis of Pahang river. *American Journal of Applied Sciences*, 10(1), 42–57.
- Hazmin, M. H., Mustapha, F., & Author, C. (2024). an Outlook on Hydropower in Malaysia: Policies, Conditions, and the Potential of Small Hydropower in Malaysian Rivers As a New Norm in Renewable Energy. *Malaysian Journal of Sustainable Environment*, 11(1), 1–24.
- Raman, N., Hussein, I., & Palanisamy, K. (2009). Micro hydro potential in West Malaysia. *ICEE 2009 - Proceeding 2009 3rd International Conference on Energy and Environment: Advancement Towards Global Sustainability, July 2015*, 348–359.
- Rusianto, T., Huda, S., Sudarsono, & Suyanto, M. (2023). Performance of Axial Generator for a Small Vertical Axis Wind Turbine. *Journal Europeen Des Systemes Automatises*, 56(2), 237243.
- Supardi, A., Raya, M. Y., & Anwar, R. S. (2021). Development of a Low Cost Portable Hydro

and Wind Power as Emergency Power Source. *Journal of Physics: Conference Series*, 1858(1).

Syahin, A. A. T., Zinnyrah, M., Sofea, R. A., Rahman, M. R. A., & Saad, M. R. (2024). Vertical Axis Wind Turbine for Low Wind Speed Environment: Effect of Scoop Harmony Blade. *E3S Web of Conferences*, 477.