

Chapter in Book

Smart UV Sterilizer

Stevan Pacoran^{1,*}, Jowie Jonatan Babo², Nurul binti Gafar³, Andri Ruben Sampe⁴, Fiona Martika⁵, and Palem Matius⁶

1 stevan.pacoran1@gmail.com
2 jowiejonathan@gmail.com
3 nrl.gfrrr@gmail.com
4 andrirubensampe123@gmail.com
5 pongtikufyona@gmail.com
6 palemmatius@gmail.com
* Correspondence: stevan.pacoran1@gmail.com

Abstract: *The sterilizer is an important tool for maintaining the cleanliness of goods. This sterilizer is based on Arduino, UV-C LED and trash can. The purpose of this product is to sterilize items using a UV lamp in a closed place. This tool works by detecting an object with a distance of about 30 cm using an Ultrasonic proximity sensor, from detection. The sensor sends a signal to the Arduino which instructs the servo to activate until the cover can be opened. Then the user puts the item into the sterilizer (the cover remains open for a predetermined time, then closes automatically). After closing, Arduino turns on the UV-C led, at that time the sterilization starts after the sterilization has finished, the cover will be opened and the user can take the sterilized item, after that the can will close by itself. Ergonomically, this sterilizer is safe to use because sterilization is carried out in a closed room and the UV-C LED does not cause irritation to the skin. This innovation is a solution to prevent the spread of germs, keep items clean from bacteria and safe to use.*

Keywords: smart sterilizer; Arduino; UV-C LED; ultrasonic proximity sensor.



Copyright: © 2022 by the authors. Submitted for open access publication under the terms and conditions of the Creative Commons Attribution (CC BY) license (<https://creativecommons.org/licenses/by/4.0/>).

1. INTRODUCTION

Sterilization using UV-C led is a common tool in users to clean goods from bacteria. According to the US Centers For Disease Control and Prevention, Sterilization means "the use of physical or chemical procedures to destroy all microbial life, including highly resistant bacterial endospores". The type of sterilization found is using UV-C LED. This type of LED is the best solution to use because it can kill germs by damaging cell membranes and changing DNA/RNA.



Figure 1. Smart UV Sterilizer

2. METHOD & MATERIAL

The main body part of the Smart UV Sterilizer is a plastic trash can measuring 23cm x 25.5cm (Diameter x Height) then fitted with an Ultrasonic Proximity Sensor, Servo Motor, Ultraviolet Led Ray, 16x2 LCD, DPFlyer, and Speaker. Arduino Uno R3 Microcontroller.

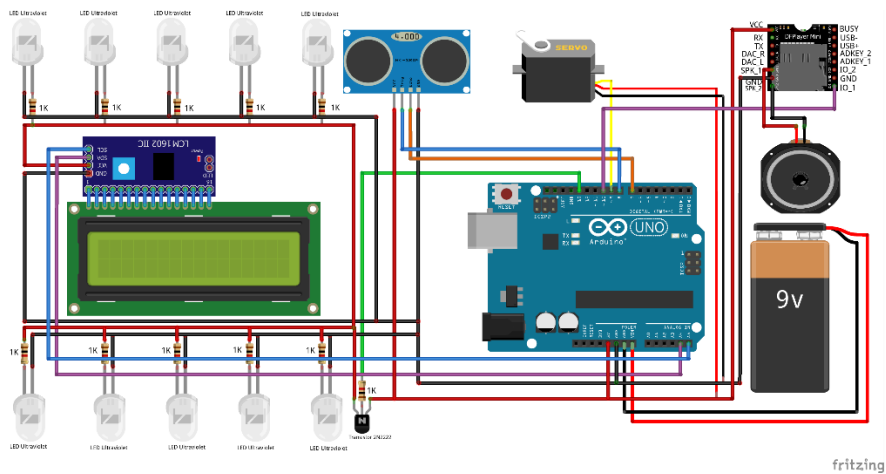

Figure 2. Internal Connection of the Smart UV Sterilizer

3. FINDINGS

What we want to improve in the future for this product is the need for sensors that can detect or calculate how many people actually use the smart UV sterilizer when it is turned on, so that we can find out how many people have used the SMART UV sterilizer after turning it on.

4. DISCUSSION

All components for smart uv sterilizer have been successfully assembled as shown in figure 3. This tool is ready to be used to sterilize goods.

1. If the ultrasonic sensor detects an obstacle or object in front with a distance of about 30 cm or less, the tool will automatically open with the duration specified in the programming.
2. After opening, the user usually enters the item they want to sterilize.
3. Then the sterilizer will close automatically.
4. The sterilization process takes place with the duration specified in the programming.
5. The process is complete, the sterilizer will automatically open.
6. after taking items that have been sterilized, the sterilizer will automatically close again.



Figure 3. Assembled of Smart UV Sterilizer

5. CONCLUSION

Well, we can conclude that the Smart UV Sterilizer can help kill bacteria by using ultraviolet light and work automatically without touching the device by applying Arduino uno microcontroller technology. Ergonomically this product is safe to use because the sterilization is carried out in a closed room and the UV-C LED does not cause skin irritation. This innovation is a solution to prevent the spread of viruses, keep goods clean from bacteria and safe to use. Sterilization is better than using water to clean items because it has the potential to wet items. The collaboration between science and technology has actually resulted in a new breakthrough in the development of STEM-based Project based learning, of course, it can help facilitate experiments and be interesting, right!

References

- Aldiansyah, M.F., Raihan, M. & Laudzai, R. (2020). Rancang bangun steril box berbasis UV-C dan SOLAR CELL. Retrieved October 25, 2022, from https://sekolahsabilillah.sch.id/assets/img/ruang_karya/smp/KIR_SMP_1.pdf
- Arsana, A. A. D. (2020, February 14). Membuat tempat sampah otomatis berbicara [Video]. YouTube. <https://www.youtube.com/watch?v=uBRjjAlHi9E&t=32s>

Patandean, N. (2020, June 28). Cara membuat tempat sampah otomatis berbicara/ Tempat sampah pintar/ Smart trash bin [Video]. YouTube. <https://www.youtube.com/watch?v=Va5K5Ss7yHU>

Syahputra, M. R. (2021). Perancangan kotak steril ultraviolet otomatis. Sumatera Utara, Medan: Universitas Sumatera Utara Medan.

U.S. Centers for Disease Control and Prevention (2008). Guideline for disinfection and sterilization in healthcare facilities. Infection Control. <https://www.cdc.gov/infectioncontrol/guidelines/disinfection/introduction.html>

Walan. (2019). Sterilisator uv dengan sistem remote kontrol berbasis microcontroller atmega328. Yogyakarta: Universitas Muhammadiyah Yogyakarta.