

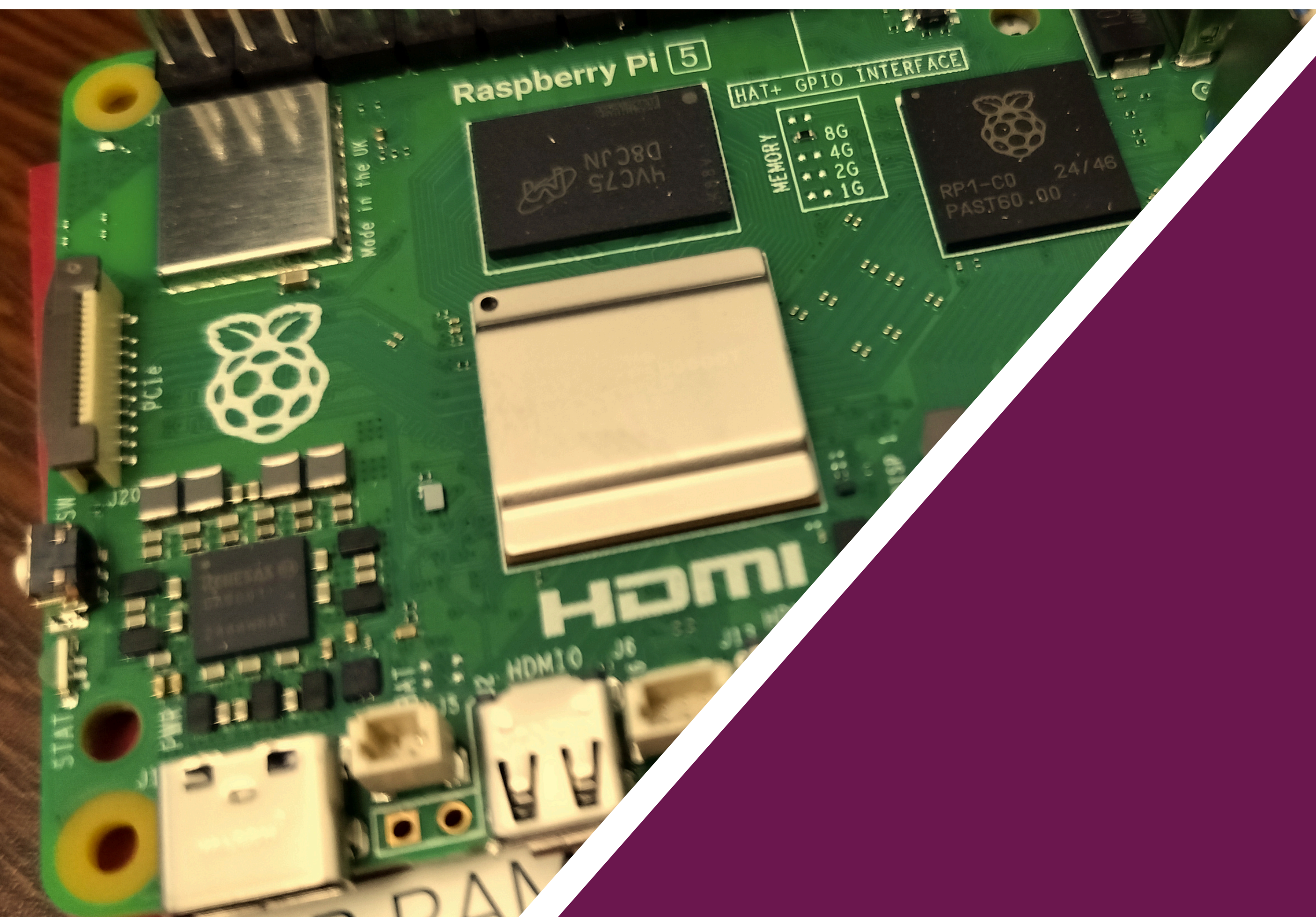

EESEE 2025

10TH ELECTRICAL ELECTRONICS SYSTEMS ENGINEERING EXHIBITION 2025

VOLUME 1



FACULTY OF ELECTRICAL ENGINEERING
UNIVERSITI TEKNOLOGI MARA
JOHOR BRANCH
PASIR GUDANG CAMPUS

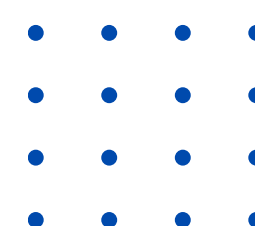

Authors

Noor Hafizah Khairul Anuar, Fazlinashatul Suhaidah binti Zahid, Nor Diyana Binti Md Sin, Zakariah Yusuf, Siti Musliha Ajmal Binti Mokhtar, Hanunah Binti Othman, Khairul Kamarudin Hasan, Masmaria Binti Abdul Majid, Siti Aminah Binti Nordin, Muhammad Asraf Bin Hairuddin, Muhammad Zairil Bin Mohd Nor, Nor Affida Binti M.Zin, Nur Asfahani Binti Ismail, Zahari Abu Bakar, Kamaru Adzha Bin Kadiran, Ezril Hisham Bin Mat Saat, Muhammad Rajaei Dzulkifli, Nur Amalina binti Muhamad, Norbaiti binti Sidik, Rozi Bin Rifin, Zatul Iffah Binti Abd Latiff, Sufian bin Mohamad, Norhalida Binti Othman, Nurul Nadia Binti Mohamad, Norlee Husnafa Binti Ahmad, Fatimah Khairiah Abdul Hamid, Wan Suhaifiza Binti W. Ibrahim, Fadila Binti Mohd Atan, Siti Aliyah Binti Mohd Saleh, Mastura Omar, Rijalul Fahmi Bin Mustapa, Atiqah Hamizah Binti Mohd Nordin, Muhammad Zairil Bin Muhammad Nor, Shakira Azeehan Binti Azli, Siti Hazurah Binti Indera Putra, Suhaili Binti Beeran Kutty.

Editors

Sufian bin Mohamad
Kamaru Adzha Bin Kadiran

Book Graphic Designer

Kamaru Adzha Bin Kadiran



EESEE 2025 10TH ELECTRICAL ELECTRONICS SYSTEMS ENGINEERING EXHIBITION
2025

e ISBN 978-967-0033-28-0



Universiti Teknologi MARA, Cawangan Johor Kampus Pasir Gudang
(Online)



Copyright © 2024 Universiti Teknologi MARA Cawangan Johor, Kampus Pasir Gudang, Jalan Purnama, Bandar Seri Alam, 81780 Masal Johor.

All extended abstracts published in this e-book have not been subject to EESEE 2025 peer review or check. The authors are responsible for the contents of their extended abstracts and warrant that their extended abstract is original, has not been previously published, and has not been simultaneously submitted elsewhere. The views expressed in the abstracts in this publication are those of the individual authors and are not necessarily shared by the editor.

All rights reserved. No part of this publication may be reproduced in any form or by electronic or mechanical means, including information storage and retrieval systems, or transmitted in any form or by any means, without the prior permission in writing from the Course Coordinator of Electrical Engineering Faculty, Universiti Teknologi MARA Cawangan Johor, Kampus Pasir Gudang.

Published in Malaysia by Universiti Teknologi MARA Cawangan Johor
Kampus Pasir Gudang 81750 Masai



FOREWORD BY THE PROGRAM CHAIR

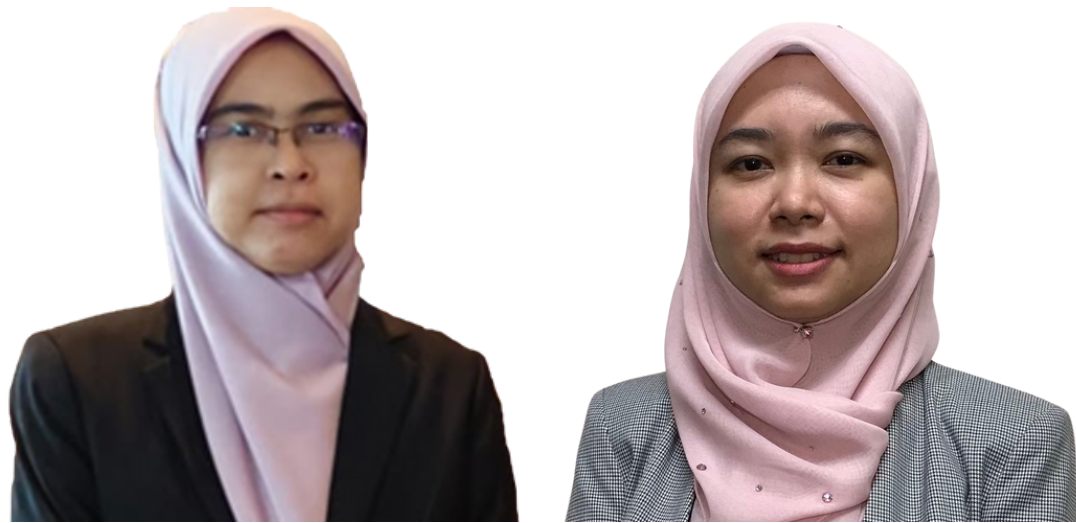

Greetings from the Electrical, Electronics, and Systems Engineering Exhibition 2025 (EESEE 2025).

As the Program Chairs, it is our great pleasure to present this compilation of extended abstracts, showcasing the remarkable projects developed by our final-semester students from the Diploma in Electrical Engineering (Power) and Diploma in Electrical Engineering (Electronics) programs at Universiti Teknologi MARA, Cawangan Johor, Pasir Gudang Campus.

This exhibition marks a significant milestone in our students' academic journey, representing the culmination of years of dedication, perseverance, and learning. It also serves as an essential step toward the successful completion of their diploma studies. The projects featured this year are centered on the theme *Engineering Excellence: Bridging Technology and Life*, reflecting current trends and innovations in the engineering field.

This extended abstract book highlights not only the students' technical expertise but also their creativity, problem-solving skills, and ability to engage meaningfully with peers and industry professionals. Within these pages, you will find a diverse range of projects that embody a unique blend of knowledge, innovation, and practical application.

We warmly invite you to explore this collection, which celebrates the achievements of our aspiring engineers. Welcome once again to the Electrical, Electronics, and Systems Engineering Exhibition 2025. May the insights shared here inspire and pave the way for the next generation of innovative engineers.

Warm regards,

Dr. Fatimah Khairiah binti Abd Hamid

Dr. Atiqah Hamizah binti Mohd Nordin

Program Chairs

Electrical, Electronics, and Systems Engineering Exhibition 2025 (EESEE 2025)



An Interactive Three-Phase Electrical System Educational Tool Using Matlab App Designer

Siti Nur 'Aisyah Binti Shamsudin¹, Dr. Atiqah Hamizah Binti Mohd Nordin²

^{1,2}*Electrical Engineering Studies, College of Engineering, Universiti Teknologi MARA, Pasir Gudang, Johor.*
2022858568@isiswa.uitm.edu.my

ABSTRACT

This project develops an interactive educational tool using MATLAB App Designer to enhance the understanding of three-phase electrical systems, addressing the limitations of traditional teaching methods in conveying concepts such as phase sequence, balanced loads, and power relationships. The tool features intuitive layouts for phase sequence determination, balanced load analysis, three-phase system parameter calculations, power triangle visualization, and one-line diagram modelling, enabling users to input values, simulate system behaviour, and observe detailed voltage and current waveforms, power calculations, and phase relationships in real time, altogether six layouts development. The methodology includes designing a user-friendly interface, structured workflows with block diagrams and flowcharts, and iterative testing to ensure accuracy and usability. The tools also equipped with pre-defined inputs for user as reference. Results show that the developed tool successfully generates outputs accurately for each developed layout and they were validated theoretically. In addition, this tool offers detailed simulations with the aids of waveforms and diagrams to enhance users' understanding on the three-phase system. Ultimately, this comprehensive tool serves as a valuable resource for electrical engineering students and educators as educational tool by improving engagement and comprehension by experiential learning.

Keywords: Three-Phase Electrical Systems, MATLAB App Designer, Interactive Educational Tool, Graphical User Interphase

PRODUCT DESCRIPTION

The Interactive Three-Phase Electrical System Educational Tool is a MATLAB App Designer-based software developed to enhance the understanding of complex three-phase electrical systems. It integrates multiple features, including phase sequence determination, balanced load analysis, power triangle visualization, parameter evaluation in three-phase systems, and one-line diagram representation. This tool allows users to visualize and manipulate system parameters, observe real-time voltage and current waveforms, and perform power-related calculations. The user-friendly interface, combined with interactive layouts, bridges the gap between theoretical concepts and practical applications, making it a useful resource for students and educators in the electrical engineering.

PICTURES

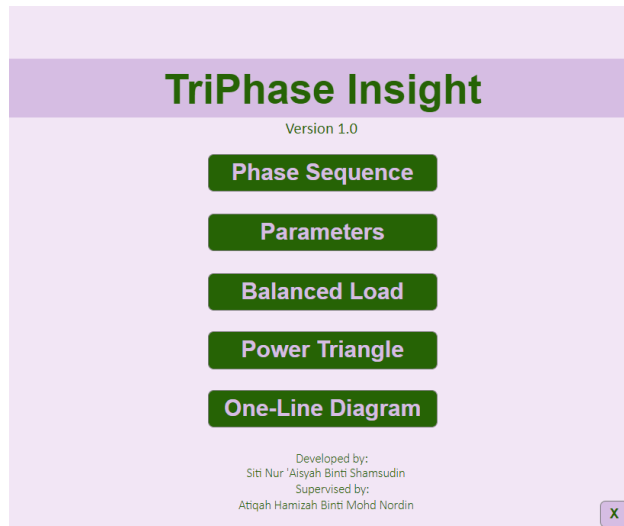

Figure 1: Main Page

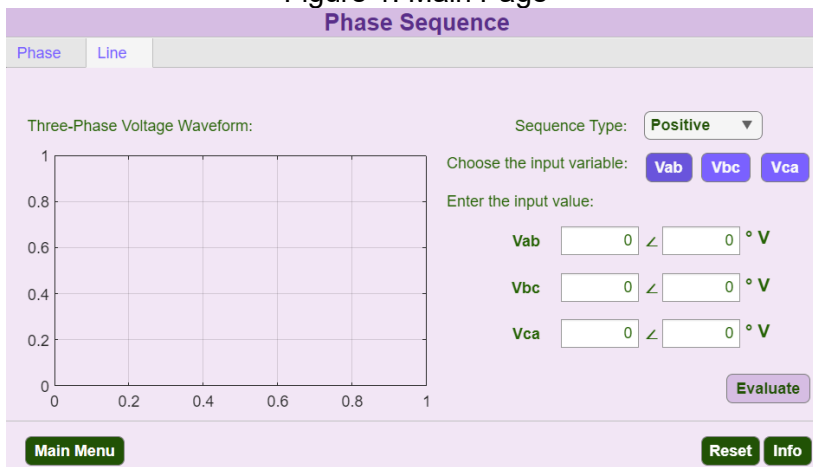

Figure 2: Page Layout for Phase Sequence

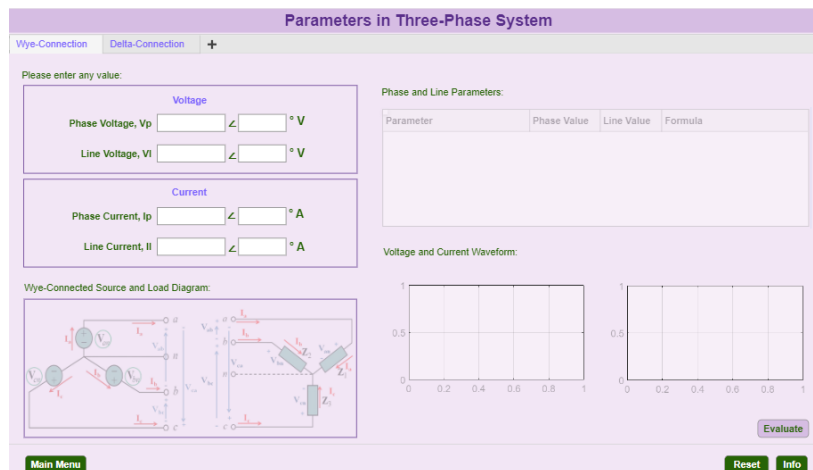

Figure 3: Page Layout for Parameters in Three-Phase System

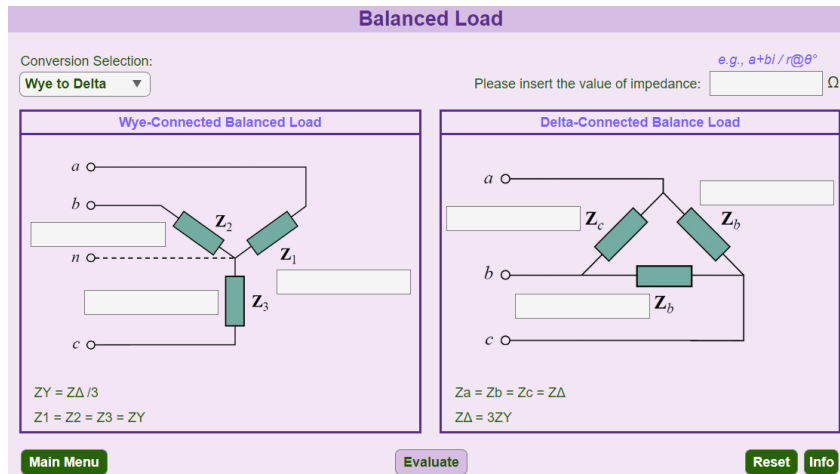

Figure 4: Page Layout for Balance Load

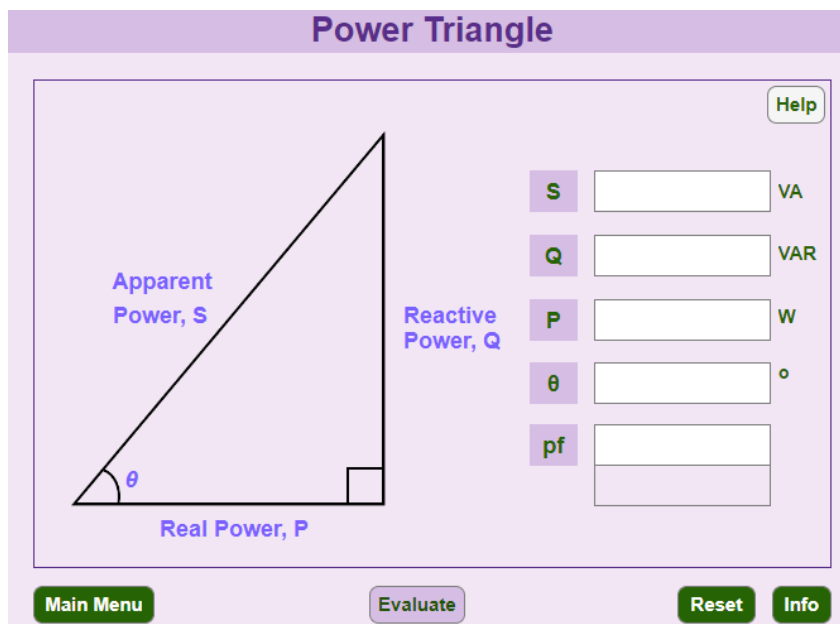

Figure 5: Page Layout for Power Triangle

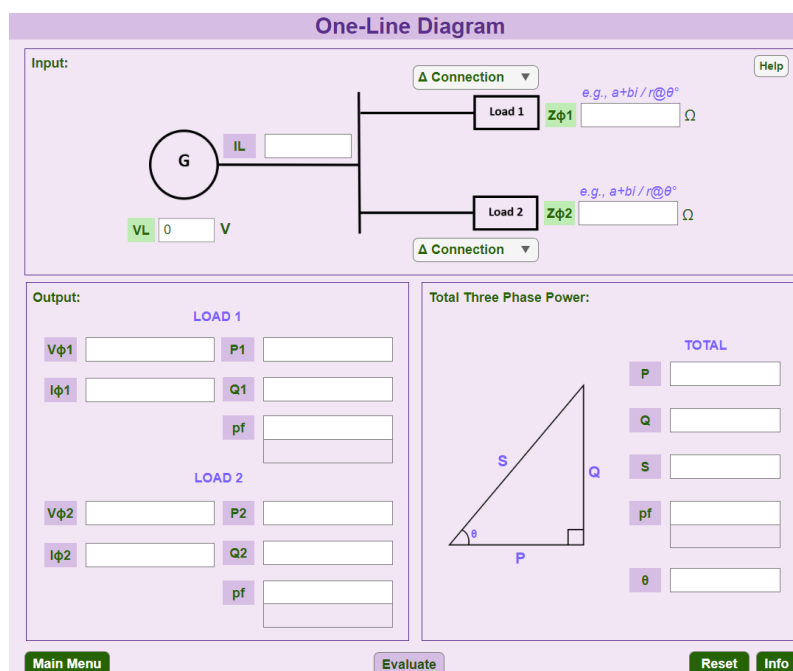

Figure 6: Page Layout for One-Line Diagram Case Studies

NOVELTY AND UNIQUENESS

This project stands out for its comprehensive integration of multiple essential topics in three-phase electrical systems into a cohesive educational tool. This project provides an interactive platform for analysing phase sequences, visualizing waveforms, performing power calculations, and studying balanced loads, all with real-time feedback. Its structure allows users to dynamically explore interrelated concepts, making it both innovative and highly user focused, hence promoting experiential learning.

BENEFIT TO MANKIND

The tool addresses the challenge of effectively teaching and learning complex three-phase electrical concepts. By offering a visual, hands-on approach, it enhances comprehension for students, improves teaching methods for educators. Ultimately, it contributes to producing better-trained electrical technician/engineers.

COMMERCIALIZATION POTENTIAL

The tool has strong commercialization potential as an educational software product targeted at universities and technical institutions. It can be offered as a standalone simulation tool or included in electrical engineering courses. Adding extra features like advanced analysis options or connections to real hardware could make it even more attractive. It could generate income through subscriptions, licenses for schools, or partnerships with training programs.

CONCLUSION

The Interactive Three-Phase System Educational Tool Using MATLAB App Designer marks a significant innovation in electrical engineering education. By integrating interactive layouts for phase sequence analysis, balanced load evaluation, power triangle visualization, three-phase parameters, and one-line diagrams, the tool delivers a comprehensive learning experience. Its user-friendly interface, practical functionality, and real-time simulations effectively bridge the gap between theoretical knowledge and practical application, enabling students to gain a deeper understanding of three-phase electrical concepts. This project not only enhances education but also paves the way for innovative teaching methodologies and industry applications.

REFERENCES

- [1] Han Ping, He Weikun, Shi Qingyan and Han Yan, "An educational tool design for the course of signal processing based on Matlab GUI," 2014 IEEE International Conference on Teaching, Assessment and Learning for Engineering (TALE).
- [2] Z. Conka, M. Bobcek, R. Stefko and M. Karabinos, "GUI Interface Design in MATLAB App Designer Environment for Electronic Load in Hybrid Systems," 2024 IEEE 22nd World Symposium on Applied Machine Intelligence and Informatics (SAMI), Stará Lesná, Slovakia, 2024.
- [3] Y. An, C. Deng, Q. Zheng and J. Wang, "Three-phase Power Flow Calculation Method Based on User Phase Sequence Identification," 2023 3rd International Conference on Electrical Engineering and Control Science (IC2ECS), Hangzhou, China, 2023.
- [4] Nordin, A. H. M., Mustapa, R. F., Zainuddin, A., & Ismail, H. B. (2018). Interactive Learning of Electrical Machines Using ELMA Tool.
- [5] Nordin, A. H. M., Mustapa, R. F., Mahadan, M. E., Ahmad, N. H., & Dahlan, N. Y. (2017). Transformer interactive learning tool based on MATLAB Simulink and GUI.
- [6] Noor, S. M., Hamzah, M., & Yunus, P. M. (2013). Three phase induction motor analysis using MATLAB/GUIDE.