

TikTok Video Credibility: A Purchase Decision Among Consumers in Pahang, Malaysia

**Tan Wei Xuan¹, Ng Moi Kee², Khoo Yi Shuen³, Mohd Remie Mohd Johan^{4*},
Tun Norasida Aziz⁵, Nursyamilah Annuar⁶**

^{1,2,3,4,5} *Tunku Abdul Rahman University of Management and Technology,
Pahang Branch, 25200 Kuantan, Pahang, Malaysia*

⁶ *Faculty of Business and Management, Universiti Teknologi MARA, Cawangan Perlis,
Kampus Arau, 02600 Arau, Perlis, Malaysia*

Authors' Email Address: ¹tanwx-cb22@student.tarc.edu.my, ²ngmk-cb22@student.tarc.edu.my, ³khoos-cb22@student.tarc.edu.my, ⁴mohdremie@tarc.edu.my, ⁵tunnorasida@tarc.edu.my ⁶nsyamilah@uitm.edu.my

Received Date: 16 Oct 2025

Accepted Date: 9 Dec 2025

Revised Date: 15 Dec 2025

Published Date: 31 Jan 2026

*Corresponding Author

ABSTRACT

This study examines the influence of TikTok video credibility on consumer purchasing decisions among users in Pahang, Malaysia. Drawing on the theories of the Technology Acceptance Model, this study examines how content creativity, informativeness, influencer trustworthiness, engagement metrics, and product review quality influence consumer trust and purchasing behavior. Using a quantitative approach with survey data from 403 active TikTok users, the research employs Partial Least Squares Structural Equation Modeling (PLS-SEM) to analyze the relationships between these variables. Results indicate that content creativity, influencer trustworthiness, and engagement metrics have a significant impact on purchase decisions, whereas informativeness does not exhibit a substantial influence on these decisions. The findings underscore the significance of authentic, engaging, and creatively produced content in influencing consumer behavior on TikTok, offering valuable insights for marketers who seek to optimize their video strategies within the local Malaysian context. The study contributes to understanding the social media credibility factors that drive consumer purchasing in semi-urban markets.

Keywords: *content, engagement, informativeness, product, trustworthiness*

INTRODUCTION

TikTok has proven to be popular among the younger population, with 41% of its users aged 16-24, and 90% of TikTok users claim to use the app regularly, and it has grown to be one of the world's most

popular social media platforms (Weimann & Masri, 2020). In early 2024, there were approximately 5.71 million X users in Malaysia, 22.35 million Facebook users, 24.1 million YouTube users, and 28.68 million TikTok users aged 18 and above (Reuters, 2025). Trustworthiness, relatability, and authenticity of influencers on TikTok significantly drive purchase intentions (Madhavedi et al., 2025). Thus, TikTok has become a digital content consumption powerhouse and continues to shape how consumers make their purchasing decisions. TikTok is most popular in Malaysia among Generation Z, who rely on short videos not only for entertainment but also for discovering new products and services. Its rapid growth and engaging short-video format have made it a preferred platform for both entertainment and information, including product discovery (Xie, 2024). Video credibility has emerged as a crucial factor influencing consumer decisions as more businesses use TikTok as an advertising platform. Here, credibility is established by factors including content originality, informativeness, influencer trustworthiness, engagement rates, and the quality of product reviews. The audience is more likely to react and make a purchase if they believe the material to be legitimate (Shamsuddin & Azman, 2025).

Video credibility can be understood as how much the audience perceives and has faith in the messages they view. In social media marketing, various factors decide credibility. Creativity in content makes a contribution by grabbing the attention of the viewers through narrating a story, humor, or emotional appeal. When videos are presented creatively, the viewers engage more and have a positive perception of the product being promoted (Shamsuddin & Azman, 2025). Informativeness is also a major determinant. Videos that are able to clearly explain product characteristics, benefits, and uses have the propensity to reduce uncertainty and allow consumers to confidently make a decision. Informative videos allow consumers to better understand the product, thus increasing the likelihood of a purchase (Dwinanda et al., 2022). The credibility of the influencer also plays a role. Viewers are likely to accept and follow the recommendations of influencers who appear honest, credible, and authentic. A credible influencer builds trust with their followers and is better equipped to alter attitudes towards a product (Mahmud et al., 2024). Engagement metrics such as likes, shares, comments, and product reviews are key indicators of social proof. An engaging video that attracts high levels of interaction often suggests that the product is valuable or in high demand, impacting the level of trust people place in it. These visible reactions contribute to the perceived quality and reliability of the content (Khalid et al., 2023). In particular, product reviews in videos that are clear, real, and balanced enable potential consumers to have a better comprehension of the product's strengths and weaknesses. When the reviews sound sincere and comprehensive, consumers are likely to form a positive impression and move toward buying (Mahmud et al., 2024).

Problem Statement

The transformation of the digital market has given marketers new ways to connect with customers, develop trust, and keep loyalty (Yap et al., 2025). However, marketers increasingly rely on TikTok to reach young consumers, yet most still have no clue what video attributes actually influence purchasing decisions. Videos generated by healthcare experts or nonprofit organizations are typically higher quality and more reliable. In contrast, those created by general users, influencers, or for-profit corporations are more likely to contain misinformation or lack evidence-based content (Vitale et al., 2024; Yeung et al., 2022; Xue et al., 2022).

Previous studies on TikTok video credibility have shown that high-quality, reliable, and engaging material enhances perceived usefulness and trust, thereby promoting acceptance and behavioral intentions (Tien et al., 2025; Setiawan et al., 2024; Wang et al., 2022). The gap leaves one wanting to know what it is about a video that makes it credible enough to induce purchasing behavior. Whereas these credibility factors have already been investigated in wider national research, there is relatively little attention given to particular East Coast regions such as Pahang. The Pahang Palace detected fake TikTok accounts producing AI-generated videos using the Sultan's image to deceive the public, highlighting the need for research on video credibility on the platform (Kesultanan Pahang,

2025; Bernama, 2025). Pahang consumers may judge credibility on different factors or put more weight on specific video elements. Without local knowledge, businesses risk creating content that will not engage or convert as effectively. This study fills this gap by investigating the impact of the five basic elements of video credibility on purchase intention among TikTok users in Pahang. TikTok continues to revolutionize the digital marketing space by rendering short-form video content a direct determinant of consumer behavior. The credibility of these videos greatly affects viewers to engage with the content and proceed to make a purchase. Trust plays a crucial role in helping consumers overcome perceived risks and uncertainties (Shao et al., 2022). Thus, it is necessary that businesses comprehend the singular determinants of video credibility so that they can build trust and influence consumer behavior. These determinants include content creativity, informativeness, influencer trustworthiness, engagement metrics and product review quality. This research aims at Pahang consumers and hopes to learn about the influence of these five credibility factors on purchase behavior. The findings should help marketers and content creators develop more effective and credible video content that mirrors the interests and needs of local audiences.

Research Objectives

- RO1:** To explore the impact of creative content on the purchasing decision of consumers through TikTok videos in Pahang.
- RO2:** To assess the manner in which informativeness on TikTok videos affects Pahang consumers' purchase decisions.
- RO3:** To determine the influence of influencer credibility on customer buying behavior in Pahang.
- RO4:** To provide empirical evidence on the impact of engagement metrics on purchase intentions of TikTok among Pahang consumers.

Research Question

- RQ1:** How does content creativity in TikTok videos influence consumer purchase decisions in Pahang?
- RQ2:** Does the informativeness of TikTok content affect consumer purchase decisions in Pahang?
- RQ3:** To what extent does influencer trustworthiness influence consumer purchase decisions in Pahang?
- RQ4:** What is the impact of engagement metrics on purchase decisions among TikTok users in Pahang?

LITERATURE REVIEW

Research Model

Information and communication technology is a rapidly evolving phenomenon (Annuar et al., 2021). Thus, this study adopts the Technology Acceptance Model (TAM) to examine how TikTok videos influence consumer purchase decisions through message processing and user acceptance of content. The Technology Acceptance Model (TAM) explains how users come to accept and use new technologies, focusing on two main factors: Perceived Usefulness (PU) and Perceived Ease of Use (PEOU). In the context of TikTok, PU refers to how helpful a video is in aiding purchase decisions, while PEOU relates to how easily users can navigate and understand content. Studies have found that when users find TikTok product-related videos both useful and easy to consume, they are more likely to trust the content and consider purchasing the featured product (Wandira et al., 2024). Research shows that social media users are more inclined to engage with content that provides clear value and is easy to interpret (Zulkarnain & Adam, 2021). Similarly, perceived interactivity and enjoyment on platforms like TikTok can further enhance acceptance and behavioral intention to purchase (Huimin & Albattat,

2024). TAM thus offers a strong framework for understanding how and why users engage with TikTok content that influences buying behavior (Musa et al., 2024).

Purchase Decision (PD)

The purchase decision is identified as the key outcome variable in this study, representing whether consumers ultimately choose to buy a product after viewing TikTok videos. This decision is heavily influenced by the characteristics of the video content, such as its creativity, clarity, and the trustworthiness of the presenter. TikTok's short-form video format enables marketers and influencers to deliver persuasive messages that appeal to both the emotions and logic of viewers, which significantly shapes consumer buying behavior (Ying & Chein, 2021). Previous studies have reported that several psychological and social factors within TikTok content contribute to increased purchase intentions. The entertainment value, informativeness, and aesthetic appeal of a video enhance the perceived value of the product featured, encouraging consumers to take action (Ab Hamid & Adnan, 2022). Moreover, TikTok's algorithmic recommendation system reinforces this effect by showing users repeated content aligned with their preferences and behavior, which can lead to impulse purchases (Benmiloud et al., 2024). Repeated exposure enhances familiarity and perceived relevance, two key factors in decision-making. Influencer marketing on TikTok is also a dominant force in shaping purchase decisions. Influencers, especially micro influencers, are often perceived as authentic, relatable, and trustworthy, which is highly persuasive to younger consumers like Generation Z (Wahyudi et al., 2025). This is consistent with findings of past studies, which show that such influencers create a sense of peer-like connection, allowing their endorsements to act as a heuristic shortcut in the decision-making process. Instead of conducting extensive research, users may rely on these trusted creators to validate their choices, accelerating the path to purchase. In this way, TikTok serves not just as a content platform but as a powerful engine for social commerce, where entertainment, trust, and personalization converge to influence consumer decisions (Vidani & Das, 2021).

Content Creativity (CC)

Content creativity can be defined as the originality, innovation, and artistic elements used in TikTok videos to capture and sustain viewer attention. This includes creative storytelling, use of trending music, visual effects, humor, and seamless editing techniques that make content more dynamic and engaging. On a fast-paced platform like TikTok, where users scroll rapidly, highly creative content stands out, increases watch time, and leaves a memorable impression. According to Rathy (2023), when creativity is used effectively, it enhances the clarity of the message and presents product value entertainingly and naturally. Research shows that emotionally stimulating and creatively presented content significantly enhances viewer engagement and persuasion (Boberets, 2024). Moreover, creative visuals and originality in short-form videos are positively associated with higher levels of emotional connection and user satisfaction, both of which can lead to increased purchase intention (Boberets, 2024).

Informativeness (I)

Informativeness is generally understood as the extent to which a TikTok video provides clear, accurate, and relevant information about a product or service, such as price, features, usability, and benefits. This informational value plays a vital role in shaping consumer perceptions and purchase decisions by reducing ambiguity and helping users make informed choices. TikTok content often integrates product knowledge into short, engaging formats such as product unboxings, tutorials, and user reviews that are more relatable than traditional advertisements (Shi et al., 2023). These informative presentations enable users, especially Generation Z, to absorb key product details quickly while still being entertained (Devi et al., 2024). Moreover, when users perceive a video as educational

rather than purely promotional, it enhances message credibility and builds trust. Informative content increases cognitive involvement and reduces the need for external research, allowing users to feel more confident and empowered in their decision-making. Therefore, it can be concluded that videos that balance entertainment with practical information are more likely to influence consumer behavior positively by appealing to both emotion and rational evaluation (Garcia, 2024).

Influencer Trustworthiness (IT)

The credibility of social media content is generally determined by the trustworthiness of the marketers publishing and sharing information (Mohd Johan et al., 2022). Thus, influencer trustworthiness refers to the perceived honesty, reliability, and authenticity of a TikTok content creator. Consumers are more inclined to trust influencers they find relatable or who align with their personal values. When influencers communicate sincerely, share genuine experiences, and visibly use the products they promote, their message is perceived as more credible (Boas et al., 2024). This perception is further supported by consistent posting behavior, non-scripted communication styles, and a history of authentic brand partnerships. Viewers, particularly from Generation Z, are sensitive to content that appears overly promotional or insincere, often rejecting influencers who seem to prioritize sponsorships over honesty (Ananda et al., 2025). Conversely, micro-influencers who maintain an authentic presence and engage in two-way communication tend to build stronger emotional connections with their audiences. These trusted relationships allow influencers to function like peer advisors, where their product endorsements feel more like personal recommendations. As a result, consumers are more likely to internalize the product message, trust the brand, and consider making a purchase. In today's digital landscape, influencer trustworthiness is a key driver of consumer engagement and significantly impacts purchase decisions on platforms like TikTok (McClellan, 2025).

Engagement Metrics (EM)

Engagement on social media platforms entails sharing information and communicating with both new and existing clients (Mohd Ali et al., 2024). Thus, engagement refers to the level of user interaction a TikTok video receives, including views, likes, comments, shares, and followers. These metrics serve as indicators of a video's popularity, relevance, and perceived value. When users encounter content with high engagement, they may interpret it as more trustworthy or worth their time, a phenomenon known as social proof, where individuals are influenced by the behavior of others. High engagement also increases the likelihood of content being promoted by TikTok's algorithm, further enhancing its visibility and reach (Heales et al., 2025). Comments provide a space for dialogue and consumer feedback, which can help viewers assess the credibility of the message and gather different perspectives before making a purchase decision (Alafwan et al., 2023). Additionally, research shows that content with high engagement can enhance emotional involvement and reinforce brand recall, particularly when the interactions appear organic and community-driven. Therefore, strong engagement metrics not only boost content visibility but also serve as persuasive cues that positively influence user trust and purchase intention (Heales et al., 2025).

Content Creativity and Purchase Decision

Based on Research Objective 1, the independent variable is content creativity. There is a positive relationship between content creativity and consumers' purchase decisions on TikTok. Creative videos that are visually appealing, emotionally engaging, and original are more likely to capture viewers' attention and influence their buying behavior. Such content enhances message retention and stands out in TikTok's fast-scrolling environment, increasing the likelihood of product recall and interest (Wediana et al., 2023). Furthermore, creative storytelling and editing techniques help establish a deeper emotional connection with the audience, which can translate into a stronger

purchase intention (Yu et al., 2024). Therefore, content creativity plays a crucial role in shaping consumer perceptions and driving purchasing decisions on TikTok.

H1: Content creativity is positively related to consumers' purchase decisions

Informativeness and purchase decision

Based on Research Objective 2, the variable is informativeness. There is a positive relationship between the informativeness of a TikTok video and consumers' purchase decisions. Due to the widespread accessibility of the Internet, consumers are no longer constrained by social expectations when making purchase decisions; instead, they rely on the informativeness of online content to make autonomous and well-informed choices (Adipradana et al., 2023). Thus, informative content that presents product features, benefits, and practical usage helps reduce consumer uncertainty and builds trust in the product. When viewers receive relevant and accurate information, they feel more confident and empowered to make informed purchasing decisions (Lee, 2025). Additionally, videos that provide demonstrations or real-life applications allow consumers to visualize the product's value, enhancing its appeal and perceived usefulness (Theodorakopoulos et al., 2025). Therefore, the clarity and relevance of information presented in TikTok videos significantly influence consumer decision-making and increase the likelihood of product adoption.

H2: Informativeness is positively influenced by consumers' purchase decisions

Influencer Trustworthiness and Purchase Decision

Based on Research Objective 3, the variable is influencer trustworthiness. There is a positive relationship between influencer trustworthiness and consumers' purchase decisions on TikTok. When an influencer appears authentic, honest, and reliable, viewers are more likely to trust the content and consider the product being endorsed. Trustworthy influencers build credibility by providing sincere reviews, consistently using the product, and maintaining transparent communication (Lisitawati et al., 2024). In contrast, content that seems overly scripted or promotional may decrease perceived authenticity and reduce purchase intent. Research shows that perceived trustworthiness significantly influences consumer attitudes toward both the influencer and the brand, making it a critical factor in shaping online purchase decisions (Lee et al., 2025). Therefore, influencer trustworthiness plays a central role in encouraging positive consumer responses on TikTok.

H3: Influencer trustworthiness has a positive relationship with consumers' purchase decisions

Engagement Metrics and Purchase Decisions

Based on Research Objective 4, the variable is engagement metrics. There is a positive relationship between engagement metrics such as likes, comments, shares, and views and consumers' purchase decisions on TikTok. High engagement acts as social proof, making viewers perceive the content as popular and trustworthy (Rainy & Mou, 2025). This perception increases the likelihood of viewers exploring the product further or making a purchase decision. Comments also provide additional insights and feedback from other users, which helps build confidence in the product. In contrast, videos with low engagement are often viewed as less relevant or credible, reducing their persuasive impact. Content with strong engagement is more likely to be promoted by TikTok's algorithm, increasing visibility and reinforcing its influence on consumer behavior (Fitriani et al., 2025).

H4: Engagement metrics positively influenced the consumers' purchase decision

Conceptual Framework

Based on the research, the conceptual framework has been generated and illustrated in Figure 1. This conceptual framework demonstrates the relationship between the independent variables, which include content creativity, informativeness, influencer trustworthiness, and engagement, and the dependent variable, the consumer's purchase decision on TikTok. As shown by the directional arrows in the diagram, each of these independent variables influences the consumer's purchase decision.

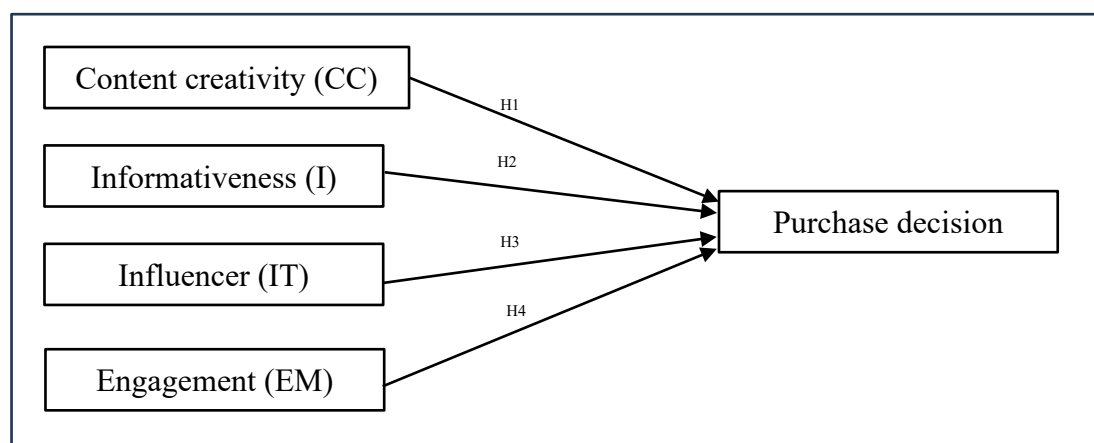

Figure 1: Conceptual Framework

This literature review has explored the growing influence of TikTok video credibility on consumer purchase decisions, particularly in the context of Pahang, Malaysia (Handoko et al., 2024). Supported by the Elaboration Likelihood Model and the Technology Acceptance Model, the review identifies key factors such as content creativity, informativeness, influencer trustworthiness, and engagement metrics as significant contributors to consumer trust and decision-making (Petty & Cacioppo, 1986; Wandira et al., 2024). Each of these variables plays a unique role in shaping how users perceive and respond to TikTok content. The framework provides a solid foundation for future empirical analysis and offers valuable insights for marketers aiming to optimize their video strategies in digital and semi-urban markets. Understanding these relationships is essential for businesses to effectively engage with audiences and drive purchasing behavior through credible and persuasive video content (Lou & Yuan, 2019; Musa et al., 2024).

METHODOLOGY

A quantitative research design was employed, using a simple random sampling method and online questionnaires to collect data. The study systematically addresses four research questions focusing on content creativity, informativeness, influencer trustworthiness, and engagement metrics as independent variables influencing consumer purchasing behavior. Using a 7-point Likert scale, the survey measures participants' perceptions of these factors. The target population comprises active social media users in Pahang, chosen through a simple random sampling method to minimize bias and enhance representativeness (Noor et al., 2022). As of 2025, Pahang has an estimated population of 1,678,200, of which approximately 29.7% (about 498,000 people) participate in social networks (DOSM, 2024). Thus, based on Krejcie and Morgan's (1970) sample size determination, 386 respondents were deemed sufficient to ensure statistical reliability and meaningful results. Thus, this study managed to collect the data from 403 respondents.

Data were collected through an online survey distributed via Google Forms that was shared across platforms such as WhatsApp, Instagram, and Facebook to reach a wide audience efficiently (Savela, 2018). Google Forms was used to develop the questionnaire, as conducting the survey through an online

platform helps maximize coverage, makes it easier to reach target respondents, and enables instant feedback delivery (Chan et al., 2020). This study contains 25 items measuring the five key variables adapted from previous validated studies — consumer purchase decision (Jumali et al., 2023), content creativity (Zhao & Kongruang, 2025), informativeness (Liu & Khong-khai, 2024), influencer trustworthiness (Mishra & Ashfaq, 2023), and engagement metrics (Rahman et al., 2017). Each construct was carefully selected to align with the research objectives and ensure construct validity.

Data analysis was conducted using Partial Least Squares Structural Equation Modeling (PLS-SEM) via SmartPLS, and data reliability, validity, and path relationships were examined. The analysis began with data coding, editing, and descriptive analysis to summarize respondent demographics and key variables. Reliability and validity were assessed through Cronbach's Alpha, Composite Reliability (CR), and Average Variance Extracted (AVE). Discriminant validity was examined using the Fornell-Larcker criterion, and the structural model was evaluated through R², SRMR, and path coefficients. The Path Coefficients/ Direct Effect (Original Sample) measure the direct influence of each construct on the Purchase Decision (PD). Participants provided informed consent, and data were collected to ensure their anonymity and privacy were safeguarded (Wei et al., 2020). Thus, ethical principles were upheld throughout, ensuring respondent anonymity, informed consent, and voluntary participation (Drolet et al., 2023). All collected data remain confidential and are used solely for academic purposes, with respondents having full rights to withdraw at any stage. Thus, for respondents' motivation purposes, the privacy and confidentiality of the information they provide are assured (Ho et al., 2024).

RESULT AND DISCUSSION

For the measurement model, all constructs demonstrated high reliability and convergent validity. Table 1 shows the data related to validity and reliability for this research, and all values exceeded the threshold criteria ($\alpha > 0.7$, CR > 0.7, AVE > 0.5), confirming construct reliability (Hair et al., 2021).

Table 1: Construct Validity and Reliability

	Cronbach's alpha	Composite reliability (CR) (rho_a)	Composite reliability (CR) (rho_c)	Average variance extracted (AVE)	Interpretation
CC	0.887	0.892	0.917	0.689	Very Good
I	0.914	0.919	0.935	0.744	Very Good
IT	0.912	0.914	0.934	0.74	Very Good
EM	0.924	0.928	0.943	0.767	Very Good
PD	0.89	0.891	0.919	0.695	Very Good

The Fornell–Larcker results in Table 2 show that most constructs meet the rule where the square root of the AVE (bold values) needs to be higher than the correlations with other constructs. However, Engagement Metrics (EM) and Purchase Decision (PD) do not meet this requirement. The AVE square root for EM (0.876) is slightly lower than its correlation with PD (0.868), and PD's AVE value (0.834) is also slightly lower than its correlation with EM. This suggests some conceptual overlap, where engagement cues such as likes, shares, and comments may be perceived as part of consumers' purchase decisions. However, because both constructs exhibit high reliability and strong theoretical justification, this issue is considered minor and acceptable in behavioral research where conceptually related constructs often correlate closely (Hair et al., 2021). Other constructs, such as IT and CC, show acceptable discriminant validity.

The HTMT results in Table 3 indicate this issue again. The HTMT value between PD and EM is 0.950, which is above the recommended limit of 0.90, indicating a clear overlap between these constructs. PD also shows a high HTMT value with Informativeness (I)(0.902), indicating respondents may not really distinguish between informativeness (I) and purchase decisions (PD). On the other hand, PD and

Influencer Trustworthiness (IT) (0.877) remain below the limit, indicating acceptable discriminant validity for that pair.

Table 2: Fornell-Larcker Criterion

	CC	EM	I	IT
EM	0.841			
I	0.910	0.936		
IT	0.801	0.870	0.817	
PD	0.890	0.950	0.902	0.877

Table 3: Heterotrait-monotrait ratio (HTMT)

	CC	EM	I	IT	PD
CC	0.83				
EM	0.774	0.876			
I	0.825	0.862	0.862		
IT	0.728	0.803	0.747	0.86	
PD	0.802	0.868	0.822	0.792	0.834

Table 4 demonstrated an excellent explanatory power ($R^2 = 0.809$) and good fit (SRMR = 0.073).

Table 4. R-Square and Model Fit

Variable	R ²	R ² Adjusted	SRMR	NFI
PD	0.809	0.807	0.073	0.706

The Path Coefficient (β) from Table 5 indicates the strength and direction of the relationship. A positive coefficient means that an increase in the predictor construct leads to an increase in the outcome construct. The relationship is considered statistically significant if the P-value is less than the standard threshold of 0.05 (or if the T-statistic is greater than 1.96) (Hair et al., 2021).

Table 5. Path Coefficient Results

Hypothesis	Path	β	T-Statistic	P-Value	Result
H1	CC → PD	0.235	4.841	0.000	Supported
H2	I → PD	0.103	1.934	0.053	Not Supported
H3	IT → PD	0.182	3.894	0.000	Supported
H4	EM → PD	0.452	8.479	0.000	Supported

This study found that H4, Engagement Metrics (EM), are the main factor influencing Purchase Decision (PD). Likes, comments, and shares act as strong social proof that builds trust and encourages consumers to buy (De Veirman & Hudders, 2020). Meanwhile, H1, which is Content Creativity (CC), also has a strong impact, as creative and emotional videos can attract attention and make products more memorable (Venciute et al., 2023). There is a significant positive relationship; creative videos effectively capture attention and influence behavior. In addition, H3, Influencer Trustworthiness (IT) increases consumers' confidence in products, showing that people trust influencers who are honest and knowledgeable (Jin et al., 2019). The results show that there is a significant positive relationship, confirming that trust in the presenter increases confidence in the product.

However, H2, Informativeness (I), was not significant with the P-value exceeding 0.05, meaning informativeness does not exhibit a substantial influence on purchase decisions and TikTok users in Pahang care more about entertainment and social connection than detailed product information. This supports the Elaboration Likelihood Model (Petty & Cacioppo, 1986), which explains that people on entertainment platforms are more influenced by popularity and emotional appeal than by facts.

This study has some limitations. It focused only on TikTok users in Pahang, Malaysia, so the results may not apply to other areas. The data were self-reported, which could include some bias. There was also a small overlap between Engagement Metrics and Purchase Decision, showing a minor issue with discriminant validity, but this is acceptable for related factors (Hair et al., 2021).

The findings show that TikTok users in Pahang rely more on social proof and entertainment rather than on detailed information when deciding what to buy. Engagement Metrics (likes, comments, shares) most influence, meaning users trust products that seem popular (De Veirman & Hudders, 2020). Creative and emotional videos also play an important role because they attract attention and make content easy to remember (Venciute et al., 2023). On the contrary, informativeness is not important; it shows that users on entertainment-focused platforms are more concerned with enjoyable and relatable content compared to factual product details, in line with the Elaboration Likelihood Model (Petty & Cacioppo, 1986).

These findings give the impression that engagement, creativity, and trustworthiness will continue to influence purchase decisions in the future. High engagement will function as a form of digital validation, creativity remains important for standing out on a crowded platform, and trustworthy influencers continue to build consumer confidence (Jin et al., 2019). Overall, social proof, creative presentation, and authentic influencer communication will play a bigger role in influencing how TikTok users make purchase decisions.

CONCLUSION

The findings of this study clearly answer the research questions and confirm the proposed hypotheses. The results show that TikTok functions more as a social and entertainment-driven commerce platform than an informational one. Content Creativity greatly influences purchase decisions, as emotionally appealing and engaging videos successfully attract attention and build positive impressions. On the contrary, Informativeness does not play a big role, showing that detailed product information is less important for TikTok users in Pahang. The study also confirms that Influencer Trustworthiness makes a clear contribution to purchase decisions, as consumers tend to rely on honest and knowledgeable influencers. Most importantly, Engagement Metrics emerged as the strongest determinant, showing that likes, comments, and shares provide strong social proof that strongly influences consumer buying behavior.

Based on this finding, marketers who want to reach TikTok users in Pahang need to shift away from information-heavy content and instead focus on creating interactive, creative, and authentic videos that encourage engagement. Prioritizing social proof, emotional appeal, and trustworthy influencer partnerships more effectively in driving purchase decisions on this platform.

ACKNOWLEDGEMENT

The author extends heartfelt gratitude to the supervisor for his invaluable guidance and support throughout the project. His expertise and advice played a crucial role in enabling the author to complete the project. The author also expresses appreciation to the faculty for providing the necessary resources to carry out the project. Additionally, sincere thanks go to the participants who generously dedicated their time to complete the survey questionnaires, contributing significantly to the success of this project.

FUNDING

This research did not receive funding from any public, commercial, or non-profit organization.

AUTHORS' CONTRIBUTION

Tan Wei Xuan, Ng Moi Kee, and Khoo Yi Shuen conceived and planned the study and carried out the data collection and analysis, as well as provided final comments and revision guidelines. Mohd Remie, Tun Norasida, and Nursyamillah provided the guidelines throughout the writing process, as well as helping with post-article refinements. All authors provided critical feedback and helped shape the research, analysis, and manuscript.

CONFLICT OF INTEREST DECLARATION

We certify that the article is the Authors' and Co-Authors' original work. The article has not received prior publication and is not under consideration for publication elsewhere. This research/manuscript has not been submitted for publication nor has it been published in whole or in part elsewhere. We testify to the fact that all Authors have contributed significantly to the work, validity and legitimacy of the data and its interpretation for submission to Jurnal Intelek.

REFERENCES

- Alafwan, B., Siallagan, M., & Putro, U. S. (2023). Comments analysis on social media: A Review. *ICST Transactions on Scalable Information Systems*. <https://doi.org/10.4108/eetsis.3843>
- Ab Hamid, M. H., & Adnan, W. H. (2022). A Systematic Review on the Understanding of TikTok's User Purchasing Behaviour towards Viral Products among Adolescents in Malaysia. *Forum Komunikasi*, 17(2), 28-43.
- Adipradana, R., Dharmawan, D. C., Mohd Johan, M. R., Shao, Z., & Annuar, N. (2023). Creating customer preferences for online marketplace promotional strategy: A survey of youth in Malaysia during the COVID-19 pandemic. *Jurnal Intelek*, 18(2), 150–162. <https://doi.org/10.24191/ji.v18i2.22272>
- Ananda, A. R., Putra, M. N. T., & Azhar, M. I. Y. (2025). Virtual Influencers, Real Impact: A Narrative Review on Credibility, Generational Trust, and Purchase Intention in Digital Marketing. *Sinergi International Journal of Communication Sciences*, 3(2), 99-112. <https://doi.org/10.61194/ijcs.v3i2.690>
- Annuar, N., Sabri, S. M., Mutalib, H. A., Rahman, N. L. A., Mutalib, S. K. M. S. A., Daud, D., & Mohd Johan, M. R. (2021). Empowering self-directed learning through technology, organization and personal support in open and distance learning: A conceptual review. *Turkish Journal of Physiotherapy and Rehabilitation*, 32(3), 23303–23310.
- Benmiloud, N., Natek, K., Khatori, Y., & Zinaoui, T. (2024). Social media and consumer impulse buying: A Systematic Review of Literature. *International Journal of Accounting, Finance, Auditing, Management and Economics*, 5(5), 22-45. <https://doi.org/10.5281/zenodo.11154754>
- Bernama. (2025, July 6). *Jangan terperdaya video ai Guna imej sultan pahang tawar Bantuan Kepada Rakyat*. Astro Awani. https://www.astroawani.com/berita-malaysia/jangan-terperdaya-video-ai-guna-imej-sultan-pahang-tawar-bantuan-kepada-rakyat-528180?utm_source=chatgpt.com
- Boas, K. V., D'Almeida, I., Alves de Oliveira, B., & Mota, R. (2024). The influence of TikTok on consumer behaviour: An analysis of how TikTok influencers affect Generation Z' consumption in the wellness sector. Dublin Business School. <https://esource.dbs.ie/server/api/core/bitstreams/f845d8f0-73eb-49c6-9a6e-e63bbec971c5/content>

- Boberets, I. (2024). The role of directing and cinematic techniques in creating advertising content on social media. *European Journal of Interdisciplinary Issues*, 1(1), 53-60.
<https://doi.org/10.5281/zenodo.14259536>
- Chan, J. M., Yeap, J. M., Taahir, A. B., & Mohd Remie, M. J. (2020). Internship program effectiveness: A job opportunity. *International Journal of Information, Business and Management*, 12(3), 94-108.
- De Veirman, M., & Hudders, L. (2020). Disclosing sponsored Instagram posts: The role of material connection with the brand and message-sidedness when disclosing covert advertising. *International Journal of Advertising*, 39(1), 94-130.
<https://doi.org/10.1080/02650487.2019.1575108>
- Devi, K. S., Nurkamilah, S., Mazidah, Z. R., Ilmi, B., Saefullah, R. S., & Kurniasih, R. I. (2024). The utilization of social media by Generation Z in information seeking: a systematic review. *KnE Social Sciences*, 362-373. 10.18502/kss.v9i12.15866
- Drolet, M. J., Rose-Derouin, E., Leblanc, J. C., Ruest, M., & Williams-Jones, B. (2023). Ethical issues in research: Perceptions of researchers, research ethics board members and research ethics experts. *Journal of Academic Ethics*, 21(2), 269-292. <https://doi.org/10.1007/s10805-022-09455-3>
- Dwinanda, B., Syaripuddin, F. A., & Hendriana, E. (2022). Examining the extended advertising value model: A case of TikTok short video ads. *Mediterranean Journal of Social & Behavioral Research*, 6(2), 35-44. <https://doi.org/10.30935/mjosbr/11820>
- Department of Statistics Malaysia (DOSM) (2024). *ICT Use and Access by Individuals and Households Report 2024*. Putrajaya: DOSM. Retrieved from
https://storage.dosm.gov.my/ictsh/ictsh_2024.pdf
- Fitriani, L. K., Ramdan, M., & Omar, A. A. (2025). Systematic Literature Review Digital Marketing Analysis of TikTokShop Application Features on Purchasing Decision. *Indonesian Journal of Strategic Management*, 8(1), 54-64. <https://doi.org/10.25134/ijsm.v8i1.11473>
- Garcia, M. B. (2024). Watching exercise and fitness videos on TikTok for physical education: Motivation, engagement, and message sensation value. *Journal of Teaching in Physical Education*, 44(3), 537-550. <https://doi.org/10.1123/jtpe.2024-0084>
- Hair, J. F., Hult, G. T. M., Ringle, C. M., & Sarstedt, M. (2021). *A primer on partial least squares structural equation modeling (PLS-SEM)* (3rd ed.). SAGE Publications.
- Handoko, W., Roziki, A. A., & Ferdinand, A. T. (2024). The effect of green social media marketing on purchase decision: a systematic literature review. *Research Horizon*, 4(4), 361-368.
- Heales, L. J., Gunasinghe, B., Melrose, E., Lorraway, J., & Obst, S. J. (2025). A systematic review of the quality and engagement of TikTok videos of resistance exercises for the management of lateral elbow tendinopathy. *Journal of Hand Therapy*, 2-6.
<https://doi.org/10.1016/j.jht.2025.02.016>
- Ho, H. R., Mohd Johan, M. R., & Muttu, T. (2024). Driving e-wallet continuance usage intention: A survey among Generation Alpha in Malaysia during COVID-19 pandemic. *Jurnal Intelek*, 19(1), 57-78. <https://doi.org/10.24191/ji.v19i1.24476>
- Huimin, X., & Albattat, A. (2024). Factors Affecting Tourist Visit Intention: Theoretical Review. *American Journal of Corporate Management*, 1(2), 50- 66.
- Jin, S. V., Muqaddam, A., & Ryu, E. (2019). Instafamous and social media influencer marketing. *Marketing Intelligence & Planning*, 37(5), 567-579. <https://doi.org/10.1108/MIP-09-2018-0375>
- Jumali, N. W., & Mustaffa, N. (2023). Digital Marketing Features in TikTok Influence Purchase Decision: A Study Among Usim Students. *Al-i'lam-Journal of Contemporary Islamic Communication and Media*, 3(2). <https://doi.org/10.33102/jcicom.vol3no2.90>
- Kesultanan Pahang. (2025, July 6). *Istana Pahang Kesan Akaun TikTok palsu Jana Video Ai Perdaya Orang Ramai*. Istana Pahang. https://istanapahang.my/istana-pahang-kesan-akaun-tiktok-palsu-jana-video-ai-perdaya-orang-ramai/?utm_source=chatgpt.com

- Khalid, J. K., Adnan, W.H., & Mohamed, S. (2023). The use of TikTok social media in influencing Generation Z online purchasing behaviour in Malaysia. *Management Research Journal*, 12(2), 40-52.
- Lee, G. K. S. (2025). Trust in social commerce: Challenges and opportunities for building consumer confidence and shaping purchase intention. *International Journal of Applied Research in Business and Management*, 6(1), 10-51137. <https://doi.org/10.51137/wrp.ijarbm.2025.gltt.45761>
- Listiawati, L., Ahmad, Y. Z., Amelia, K., & Zaelani, A. B. (2024). Analyzing the Influence of Endorsers on Brand Image Formation in Social Media: A Comparative Study of Celebrities, Influencers, and Emerging Trends. *Kampret Journal*, 4(1), 34-44.
- Liu, J., & Khong-khai, S. (2024). The Factors Influencing Consumer Purchasing Decision towards Short Video Information Flow Advertising: A Case Study of Douyin Platform. <http://ir.mju.ac.th/dspace/handle/123456789/2172>
- Lou, C., & Yuan, S. (2019). Influencer marketing: How message value and credibility affect consumer trust of branded content on social media. *Journal of interactive advertising*, 19(1), 58-73. <https://doi.org/10.1080/15252019.2018.1533501>
- Madhavedi, S., Madzri, M., Hoo, W. C., Suhud, U., & Allan, M. (2025). Factors influencing the effectiveness of social media influencers on consumer purchase intentions: A study on apparel and footwear fashion marketing in Malaysia. *International Journal of Innovative Research and Scientific Studies*, 8(2), 704–723. <https://doi.org/10.53894/ijirss.v8i2.5291>
- Mahmud, N., Lokman, A. I. N. M., Khairuddin, N., Samsul, N. N., Norazizan, S. N., & Saifuddin, S. N. (2024). Effectiveness of TikTok Marketing on Students' Purchase Intention Towards Fashion Products. *Information Management and Business Review*, 16(2), 198-204.
- Mcclellan, T., Farida, E., & Siswoyo, B. B. (2025). How Micro-Influencers Influence the Evolution of Brand Engagement: Insights from a Literature Review. *Escalate: Economics and Business Journal*, 3(1), 26-37. <https://doi.org/10.61536/escalate.v3i01.289>
- Mishra, S., & Ashfaq, R. (2023). Influencer Impact: Examining the Effect of Influencers on Consumer Behavior and Purchase. *Traditional Journal of Multidisciplinary Sciences*, 1(1), 55-72. <https://ojs.traditionaljournaloflaw.com/index.php/TJMS/article/view/86>
- Mohd Ali, A., Manogaran, S., Selvarajan, K., Tajuddin, N., Mohd Johan, M.R., & Munikrishnan, U. (2024). Digital marketing: consumers' purchase intention towards e-commerce platform for urban regions. *International Journal of Human Capital in Urban Management*, 9(3), 473–488. <https://doi.org/10.22034/IJHCUM.2024.03.08>
- Mohd Johan, M.R., Md. Syed, M.A., & Mohd Adnan, H. (2022). Malaysia small and medium-size enterprises physique brand identity persuasiveness in social media message content. *Jurnal Pengajian Media Malaysia*, 24(1), 17–34. Doi: 10.22452/jpmm.vol24no1.2
- Musa, H. G., Fatmawati, I., Nuryakin, N., & Suyanto, M. (2024). Marketing research trends using technology acceptance model (TAM): A comprehensive review of researches (2002–2022). *Cogent business & management*, 11(1), 2329375. <https://doi.org/10.1080/23311975.2024.2329375>
- Noor, S., Tajik, O., & Golzar, J. (2022). Simple random sampling. *International Journal of Education & Language Studies*, 1(2), 78-82. <https://doi.org/10.22034/ijels.2022.162982>
- Petty, R. E., & Cacioppo, J. T. (1986). The elaboration likelihood model of persuasion. In *Advances in experimental social psychology*, 19, 123-205. [https://doi.org/10.1016/S0065-2601\(08\)60214-2](https://doi.org/10.1016/S0065-2601(08)60214-2)
- Petty, R. E., & Cacioppo, J. T. (1986). *Communication and persuasion: Central and peripheral routes to attitude change*. Springer-Verlag. Retrieved from <https://link.springer.com/book/10.1007/978-1-4612-4964-1>
- Rahman, Z., Kumaran, S., Zanuddin, H., & Nasir, M. H. N. M. (2017). SM analytics: Impact of SM engagement metrics on online purchase intention. *Journal of Engineering and Applied Sciences*, 12(2), 283-289. <https://doi.org/10.3923/jeasci.2017.283.289>

- Rainy, T., & Mou, A. J. (2025). Strategic Use of Engagement Marketing in Digital Platforms: A Focused Analysis of ROI And Consumer Psychology. *Journal of Sustainable Development and Policy*, 1(1), 170-197. <https://doi.org/10.2139/ssrn.5340377>
- Rathy, A. (2023). A systematic review: The influence of TikTok contents and its effects towards mental health among youth in Malaysia. *J Media Inf Warfare*, 16(1), 1-13. <https://doi.org/10.63125/hm96p734>
- Reuters (2025). *Malaysia grants WeChat, TikTok licences to operate under new law*. reuters.com. <https://www.reuters.com/technology/malaysia-grants-wechat-tiktok-licences-operate-under-new-law-2025-01-02/>
- Savela, T. (2018). The advantages and disadvantages of quantitative methods in schoolscape research. *Linguistics and Education*, 44, 31-44. <https://doi.org/10.1016/j.linged.2017.09.004>
- Setiawan, A., Gabriella, T., Darmawan, W., & Rakasiwi, Y. (2024). Investigating e-WOM via TikTok impact on purchase intention: brand “S.” *Ranah Research : Journal of Multidisciplinary Research and Development*, 6(4), 511–518. <https://doi.org/10.38035/rrj.v6i4.854>
- Shamsuddin, A. S., & Azman, E. A. (2025). The Impact of TikTok Video Advertisements on Generation Z’s Purchase Intention: Emotional, Entertainment, and Informative Dimension. *Journal of Contemporary Management Studies*, 1(1), 13-23. <https://doi.org/10.11113/>
- Shao, Z., Kelly Lim, Q. L., Mohd Johan, M. R., & Annuar, N. (2022). Influencing consumers’ trust in online grocery shopping: A survey among Malaysian. *Jurnal Intelek*, 17(1), 128–139. <https://doi.org/10.24191/ji.v17i1.15917>
- Shi, H., Koh, J., & Park, S. (2023). Factors Influencing Users' Payment Decisions Regarding Knowledge Products on the Short-Form Video Platform: A Case of Knowledge-Sharing on TikTok. *Knowledge Management Research*, 24(1), 31-49. <https://doi.org/10.15813/kmr.2023.24.1.002>
- Taahir, A. B., Ng, Y. S., & Mohd Remie, M. J. (2020). The impact of human resource management practices on employee’s loyalty in Malaysia. *International Journal of Information, Business and Management*, 12(3), 110–125.
- Tavakol, M., & Dennick, R. (2011). Making sense of Cronbach's alpha. *International journal of medical education*, 2, 53-55. <https://doi.org/10.5116/ijme.4dfb.8dfd>
- Theodorakopoulos, L., Theodoropoulou, A., & Klavdianos, C. (2025). Interactive Viral Marketing Through Big Data Analytics, Influencer Networks, AI Integration, and Ethical Dimensions. *Journal of Theoretical and Applied Electronic Commerce Research*, 20(2), 115. <https://doi.org/10.3390/jtaer20020115>
- Tien, N. D., Hoa, V. D., & Anh, N. T. (2025). Destination choice behavior of Generation Z tourists in Vietnam: Assessing the role of TIKTOK short videos. *Hue University Journal of Science: Economics and Development*, 134(5S). <https://doi.org/10.26459/hueunijed.v134i5s.7839>
- Uyanık, G. K., & Güler, N. (2013). A study on multiple linear regression analysis. *Procedia- Social and Behavioral Sciences*, 106, 234-240. <https://doi.org/10.1016/j.sbspro.2013.12.027>
- Venciute, D., Mackeviciene, I., Kuslys, M., & Fontes Correia, R. (2023). The role of influencer–follower congruence in the relationship between influencer marketing and purchase behaviour. *Journal of Retailing and Consumer Services*, 75, 103506. <https://doi.org/10.1016/j.jretconser.2023.103506>
- Vidani, J., & Das, S. G. (2021). A Review on Evolution of Social Media Influencer Marketing: Reflection on Consumer Behaviour and Consumer's Decision-Making Process. *Turkish Online Journal of Qualitative Inquiry*, 12(9), 314-327.
- Vitale, S. G., Angioni, S., Saponara, S., Sicilia, G., Etrusco, A., D’Alterio, M. N., Cobellis, L., De Franciscis, P., & Riemma, G. (2024). TikTok as a platform for hysteroscopy information: An analytical video-based cross-sectional study to assess quality, reliability, and accuracy. *International Journal of Gynecology & Obstetrics*, 168(1), 353–361. <https://doi.org/10.1002/ijgo.15846>
- Wahyudi, M. A., Rahmadhani, M. V., Mu'is, A., & Evelyn, F. (2025). The Impact of Short-Form Video Marketing, Influencer Relatability, and Trust Signals on Gen Z’s Purchase Intention.

- International Journal of Business, Law, and Education*, 6(1), 855-864.
<https://doi.org/10.56442/ijble.v6i1.1108>
- Wandira, R., Fauzi, A., & Nurahim, F. (2024). Analysis of factors influencing behavioral Intention to use cloud-based academic information system using extended technology acceptance model (TAM) and expectation-confirmation model (ECM). *Journal of Information Systems Engineering and Business Intelligence*, 10(2), 179-190.
<http://dx.doi.org/10.20473/jisebi.10.2.179-190>
- Wang, X., Yu, Y., Zhu, Z., & Zheng, J. (2022). Visiting intentions toward theme parks: Do short video content and tourists' perceived playfulness on TikTok matter? *Sustainability*, 14(19), 12206. <https://doi.org/10.3390/su141912206>
- Wediana, N. A., Zain, F. A., & Anggraini, C. T. (2023). An Overview of Attractive Marketing Content on TikTok App Users. In *The International Conference on Psychology And Education (ICPE)*, 1, 1-105.
- Wei, W. M., Yi, L. L., Johan, M. R. M., & Zaki, N. Z. A. (2020). Improving customer satisfaction in e-commerce: A survey among Generation Z in Malaysia. *Jurnal Intelek*, 18(1), 144–154.
<https://doi.org/doi.org/10.24191/ji.v18i1.20356>
- Weimann, G., & Masri, N. (2020). Research note: Spreading hate on TikTok. *Studies in Conflict & Terrorism*, 46(5), 752–765. <https://doi.org/10.1080/1057610x.2020.1780027>
- Yap, C.W., Lim, S.Q., Soon, P.S., Wong, X.Y., Mohd Johan, M.R., Annuar, N., Mohd Ali, A., Bahari, N. (2025). Building trust and loyalty in digital marketplace: Determinants influencing online customer in Pahang, Malaysia. *Jurnal Intelek*, 19(1), 241-255. DOI: <http://10.24191/ji.v20i2.6449>
- Yeung, A., Ng, E., & Abi-Jaoude, E. (2022). TikTok and attention-deficit/hyperactivity disorder: A cross-sectional study of social media content quality. *The Canadian Journal of Psychiatry*, 67(12), 899–906. <https://doi.org/10.1177/07067437221082854>
- Ying, T. W., & Chein, T. S. (2021). Exploring The TikTok Influences On Consumer Impulsive Purchase Behavior in Malaysia. In *Proceedings of the 2nd Conference on Managing Digital Industry, Technology and Entrepreneurship (CoMDITE 2021)*, 1-271.
- Yu, S., Zhang, H., Zheng, Q., Chu, D. D., Chen, T., & Chen, X. (2024). Consumer behavior based on the SOR model: How do short video advertisements affect furniture consumers' purchase intentions? *BioResources*, 19(2), 2639-2659. [10.15376/biores.19.2.2639-2659](https://doi.org/10.15376/biores.19.2.2639-2659)
- Zhao, L., & Kongruang, C. (2025). The Impact of Short Video Content Marketing on Consumers' Purchasing Decisions. *Procedia of Multidisciplinary Research*, 3(1), 4-4. <https://so09.tci-thaijo.org/index.php/PMR/article/view/5732/3621>
- Zulkarnain, N. H., & Adam, S. (2021). A Review of Purchase Intention on Instagram among Universiti Teknologi Malaysia Local Undergraduate Students. *Journal of Modern Trends in Social Sciences*, 4(15), 114-120. [10.35631/IJMTSS.4150010](https://doi.org/10.35631/IJMTSS.4150010)
- Xie, W. (2024). Does TikTok's short video marketing increase product purchasing power among young consumers? *Lecture Notes in Education, Psychology and Public Media*, 60(1), 209–215.
<https://doi.org/10.54254/2753-7048/60/20240642>
- Xue, X., Yang, X., Xu, W., Liu, G., Xie, Y., & Ji, Z. (2022). TikTok as an information hodgepodge: Evaluation of the quality and reliability of genitourinary cancers-related content. *Frontiers in Oncology*, 12. <https://doi.org/10.3389/fonc.2022.789956>