



الجامعة  
UNIVERSITI  
TEKNOLOGI  
MARA



# PROCEEDINGS OF JOHOR INTERNATIONAL INNOVATION INVENTION COMPETITION AND SYMPOSIUM 2024 (JIICaS 2024)



*“Flourish and Nurturing Sustainable  
Innovation for a Prosperous Nation”*

# Editorial Board

## **Editors**

**NUR INTAN SYAFINAZ AHAMD**

**DR. HAJAH NORBAITI TUKIMAN**

**DR. NUR IDAYU ALIMON**

**AHMAD KHUDZAIRI KHALID**

**DR. MOHAMAD FAIZAL AB JABAL**

**DR. WAN MUNIRAH WAN MOHAMAD**

**DR. NUR SYAMILAH ARIFFIN**

**AZYAN YUSRA KAPI@KAHBI**

**NURHAZIRAH MOHAMAD YUNOS**

**NORZARINA JOHARI**

**AISHAH MAHAT**

**AZRINA SUHAIMI**

**HARSHIDA HASMY**

**DR. NG SET FOONG**

**FOO FONG YENG**

**Copyright © 2024 Universiti Teknologi MARA Cawangan Johor, Kampus Pasir Gudang, Jalan Purnama, Bandar Seri Alam, 81750 Masai Johor.**

**All extended abstracts published in this e-book have not been subject to JIIICaS2024 peer review or check. The authors are responsible for the contents of their extended abstracts and warrant that their extended abstract is original, has not been previously published, and has not been simultaneously submitted elsewhere. The views expressed in the abstracts in this publication are those of the individual authors and are not necessarily shared by the editor.**

**All rights reserved. No part of this publication may be reproduced in any form or by electronic or mechanical means, including information storage and retrieval systems, or transmitted in any form or by any means, without the prior permission in writing from the Course Coordinator of College of Computing, Informatics and Mathematics, Universiti Teknologi MARA Cawangan Johor, Kampus Pasir Gudang.**

**e ISBN: 978-967-0033-25-9**



**Published in Malaysia by  
Universiti Teknologi MARA Cawangan Johor  
Kampus Pasir Gudang  
81750 Masai**



## **Preface**

**In the name of Allah, the Almighty who gives us the enlightenment, the truth, the knowledge and with regards to Prophet Muhammad (peace be upon him) for guiding us to the straight path. We thank to Allah for giving us guidance and strength to write this e-book.**

**This e-book compiles the extended abstracts that submitted to Johor International Innovation Invention Competition and Symposium 2024 (JIIICaS2024), where JIIICaS2024 is a virtual platform for all creative minds to share and present their invention and innovation. Each abstract gives a brief background on the innovation or project.**

**We hope that this e-book will help the readers to get to know the innovation done by the students and get some ideas to develop future innovation products.**



## Foreword Rector



Assalamualaikum warahmatullahi Wabarakatuh,  
Salam Sejahtera, Salam Malaysia MADANI and  
Salam UiTM Dihatiku.

In the name of Allah, the Most Gracious, the Most  
Merciful.

It is a great honor to welcome you to the Johor  
International Innovation, Invention, Competition, and  
Symposium 2024 (JIIICaS 2024). This event

connects various disciplines, focusing on education and engaging educators,  
students, researchers, and innovators from all walks of life.

Innovation is not just about ideas; it demands perseverance, creativity, and  
determination to turn those ideas into reality. The remarkable projects  
showcased today highlight the dedication and spirit of all participants.  
Initiatives like this not only explore new technologies but also cultivate skills  
and leadership among our youth. At Universiti Teknologi MARA (UiTM) Johor  
Branch, we are fully committed to fostering a dynamic culture of innovation,  
promoting the commercialization of new products, and encouraging  
meaningful collaborations with industry and society.

As we celebrate this event, I would like to extend my heartfelt gratitude to all  
sponsors, judges, the College of Computing, Informatics and Mathematics,  
UiTM Pasir Gudang Campus as the event organizer, as well as to the  
researchers and participants for their hard work in making this event a  
success. Let us continue striving for innovation and excellence. May the  
ideas presented today inspire us and lay the groundwork for future  
achievements.

Thank you.

**Associate Professor Dr. Saunah Zainon**  
**Rector**  
**Universiti Teknologi MARA (UiTM)**  
**Johor Branch**

**(A-ST018) CONTACTLESS PETROL PUMP PAYMENT SYSTEM VIA E-ZDEY APP WITH NFC MODULE INTEGRATED**

Mohamad Muizzuddin Bin Saufi<sup>1</sup>, Hanunah Binti Othman<sup>1</sup>, Kamaru Adzha Bin Kadiran<sup>1</sup>

<sup>1</sup>Centre For Electrical Engineering Studies College Of Engineering,  
Universiti Teknologi MARA Johor Branch, Pasir Gudang Campus

hanun204@uitm.edu.my

The global landscape of petrol payment systems is rapidly changing, with a greater emphasis on safety, effectiveness, and user convenience. The COVID-19 epidemic has resulted in an immediate need for contactless transactions, exacerbating the challenges faced by current systems and necessitating creative solutions. This endeavor tackles these problems by introducing an E-zdey Petrol Pump Payment System that uses Near Field Communication (NFC) technology and an integrated software or hardware approach. The primary goals of this project are to create a prototype for a contactless fuel pump payment system that includes hardware components such as the ESP32, PN532 NFC Module, Infrared Sensor, and YF-S401 water sensor, as well as to create a mobile application that uses NFC technology to enable a safe and seamless fuel pump payment system. The methodology for this project is divided into two components, which are ESP32-based hardware components and the development of an Android-based application that compliments the system. The seamless communication between the hardware and the application is the framework of this innovative payment system. The proposed E-zdey application system allows users to leverage mobile devices for performing contactless payments via e-wallets which also stores all of the necessary data, such as balance, transaction history, and payment method format. Users must enter the value into their E-zdey app and choose whether to refuel in Ringgit Malaysia (RM) or Liters. Potential advantages of this project go over the immediate safety and effectiveness. Future recommendations embrace widespread usage of NFC-enabled petrol pump systems, which will contribute to a more secure and efficient fuel transaction experience.

Keywords: Contactless Payment, Near-Field Communication, E-wallet, Security, Android-based Application

## **1.0 INTRODUCTION**

Technology advancements have transformed payment systems, particularly in the gasoline retail business. The introduction of Near Field Communication (NFC) technology and the growing use of E-wallets offer a new opportunity to rethink gas station payments, addressing the challenges faced by the current systems and ensuring secure, efficient, and user-friendly transactions. Currently, fuel stations mostly accept standard payment options such as credit and debit cards, as well as cash transactions [1]. This project is crucial for developing a prototype that allows consumers to make contactless payments at petrol stations using NFC [2] and the E-zdey app. The value of contactless payment systems cannot be

overstated, especially in light of the global COVID-19 pandemic. This strategy enhances transactional efficiency while also helping to minimize the transmission of infectious pathogens in public settings by reducing the number of physical contact points [3]. The proposed fuel pump system consist of ESP32 microcontroller, PN532 NFC Module, Infrared Sensor, DC water pump, YF-S401 water sensor, and buzzer, are meticulously configured to ensure optimal performance. In the world of software development, creating an Android application with Android Studio and Kotlin takes center stage [4]. This application, with its user-friendly interface, aims to enable seamless interactions. The integration with a MySQL database is critical for secure data management, and a dedicated server is essential for enabling real-time communication between the application and hardware components [5].

## 2.0 OBJECTIVE

- I. To develop an E-zdey mobile application system that leverages an e-wallet app to store all the necessary data such as balance, transaction history, and payment method layout.
- II. To design a prototype of a contactless fuel pump payment system that allow users to select between Ringgit Malaysia (RM) and Liters primarily using an ESP32, PN532 NFCModule, Infrared Sensor, and YF-S401 water sensor.

## 3.0 METHODOLOGY

### BLOCK DIAGRAM

**Figure 3.1** depicts the block diagram of the E-ZDEY Petrol Pump Payment System with NFC Module. The technology uses an infrared sensor to detect any car at the gas station. When an infrared sensor detects a car nearby, the Near Field Communications (NFC) Module activates an NFC-enabled payment for transactions, and the buzzer beeps when the transaction is successful. Following that, the water flow sensor will determine the amount of fuel dispensed. Each pump station has a push button that serves as an emergency stop. This device relies on a push stop button to prevent accidents such as explosions caused by gasoline leaking.

The project operates on input data via an ESP-32 microcontroller. The ESP32 is a low-cost Wi-Fi microchip with a full Transmission Control Protocol / Internet Protocol (TCP/IP) stack and microcontroller functionality that is commonly utilized in the development of IoT (Internet of Things) apps. One of the ESP32's advantages is its ease of use and adaptability. It can be used as a microcontroller on its own or as a wireless communication module in other electronic projects. Water pumps are utilized to dispense fuel from the fuel tank. The amount of fuel dispensed and the price per liter will be displayed on the LCD screen. The customer can see the cost of fuel per litre dispensed by gazing at the LCD display. The smartphone application functions as an e- wallet, while the Application Programming Interface (API) serves as the e- wallet's server.

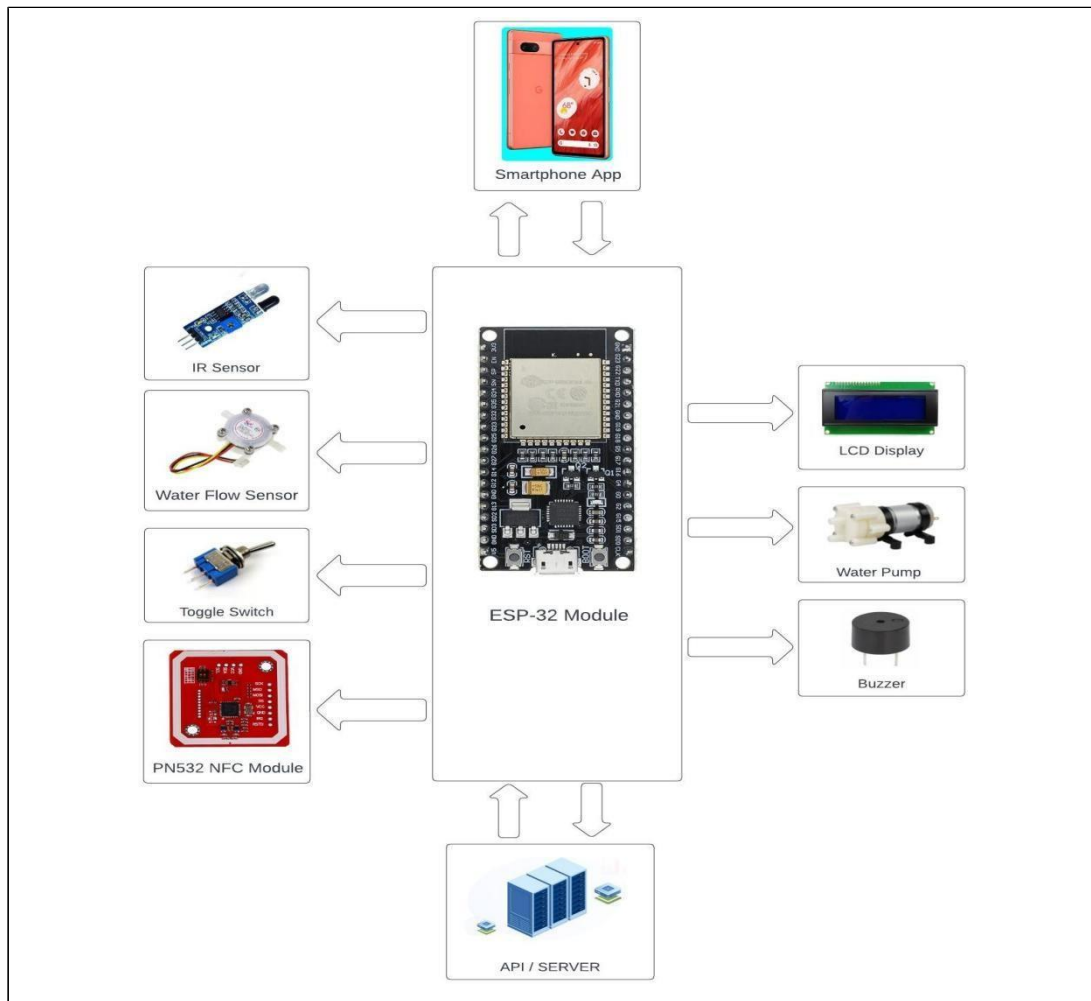

Figure 3.2 Overall Block Diagram of E-ZDEY Petrol Pump Payment System via NFC

### HARDWARE OPERATIONAL FLOWCHART

The hardware system flowchart is illustrated in **Figure 3.2**. The hardware flowchart represents a systematic sequence of processes for the petrol pump payment system. It begins with the IR sensor recognizing the presence of a vehicle, which initiates the transaction procedure. Following that, the NFC reader evaluates data to determine whether a compatible device is in close vicinity.

Following successful verification, consumers have the option to select their chosen filling method, either Ringgit Malaysia (RM) or liters. The system then computes the cost of fuel using the predetermined price rate. If the user selects RM, the computation takes into account the selected fuel volume. After this, the system begins dispensing fuel. As fuel delivery begins, the system monitors the volume of fuel supplied in real time. The process iterates, determining whether the dispensed fuel has reached the desired cost. If so, the system completes the fueling procedure. If not, the dispensing will continue until the target cost is met.

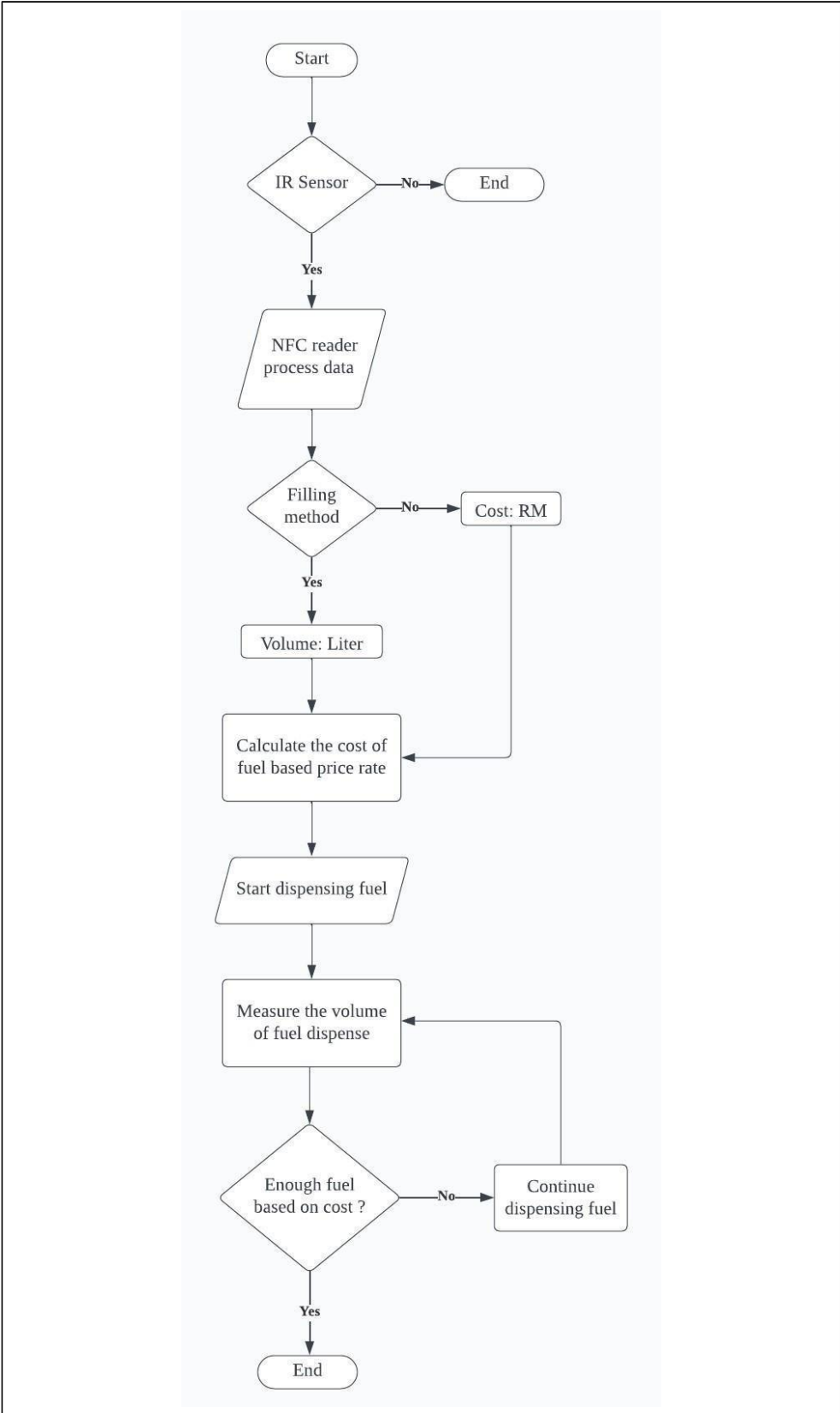

Figure 3.2: Hardware System Flowchart

## SOFTWARE OPERATIONAL FLOWCHART

**Figure 3.3** represents the application interface operational flowchart. The software flowchart depicts the operational processes of the user interface for the petrol pump payment system. It begins with the MySQL database, which stores user credentials. Users start the procedure by visiting the app's login page and entering their username and password. The system then validates the credentials entered; if they are correct, users are directed to the refueling page. If the credentials are incorrect, users are kept on the login screen, assuring security. After successfully logging in, users are sent to the refuel page, where they may select their preferred method, either in Ringgit Malaysia (RM) or liters. They then enter the necessary amount of RM or liters to start the refueling procedure. The system processes and transfers this data via the NFC module, allowing for safe communication between the program and the hardware components. This concise flowchart depicts the logical sequence of user engagements, resulting in a secure, intuitive, and efficient petrol pump payment experience via the integrated software application.

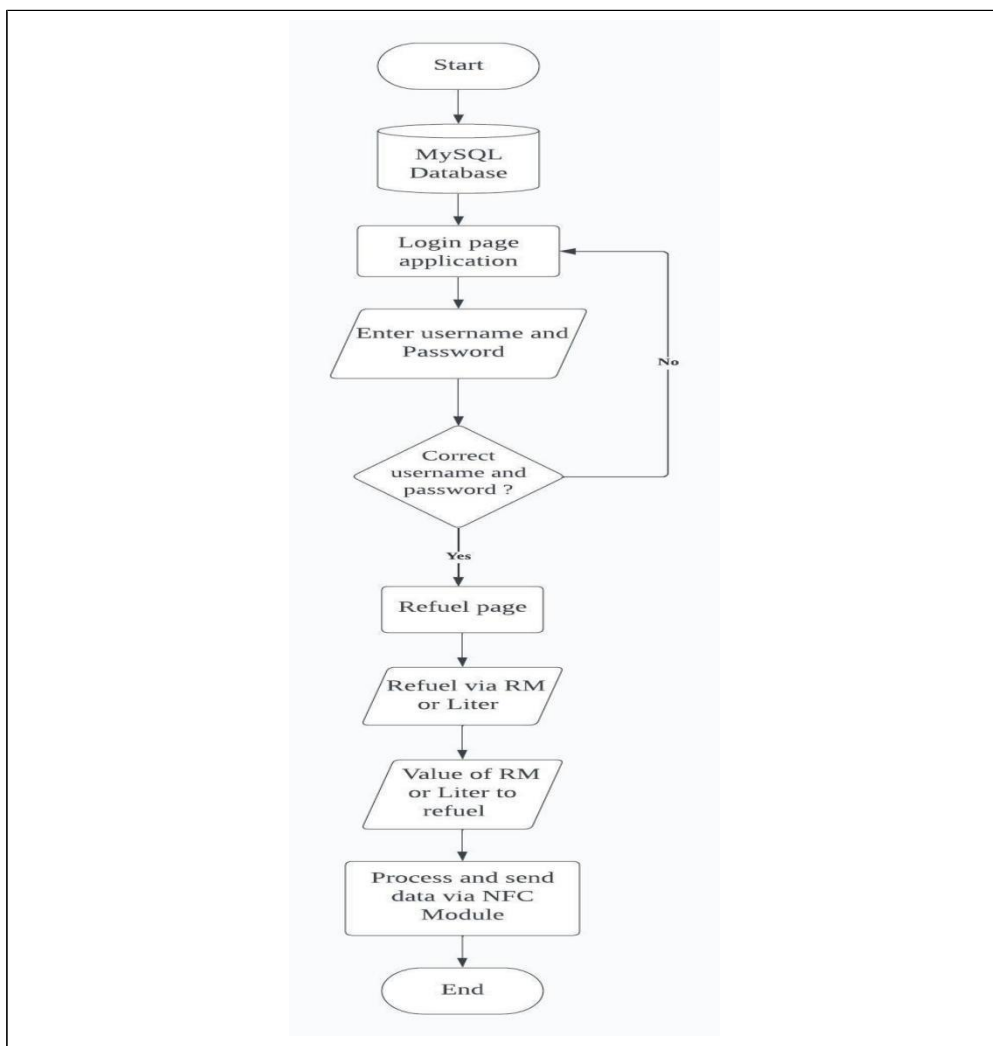

Figure 3.3: Application Interface Operational Flowchart

### SCHEMATIC DIAGRAM

According to **Figure 3.4**, every component is designed in a complete circuit using Proteus 8 Professional. To avoid a short circuit in the system, every component connection must be checked prior to hardware assembly. E-zdey Petrol Pump Payment System using NFC module circuit is critical since the system requires 12 volts to run the water pump. Safety measurements should be taken properly during circuit design.

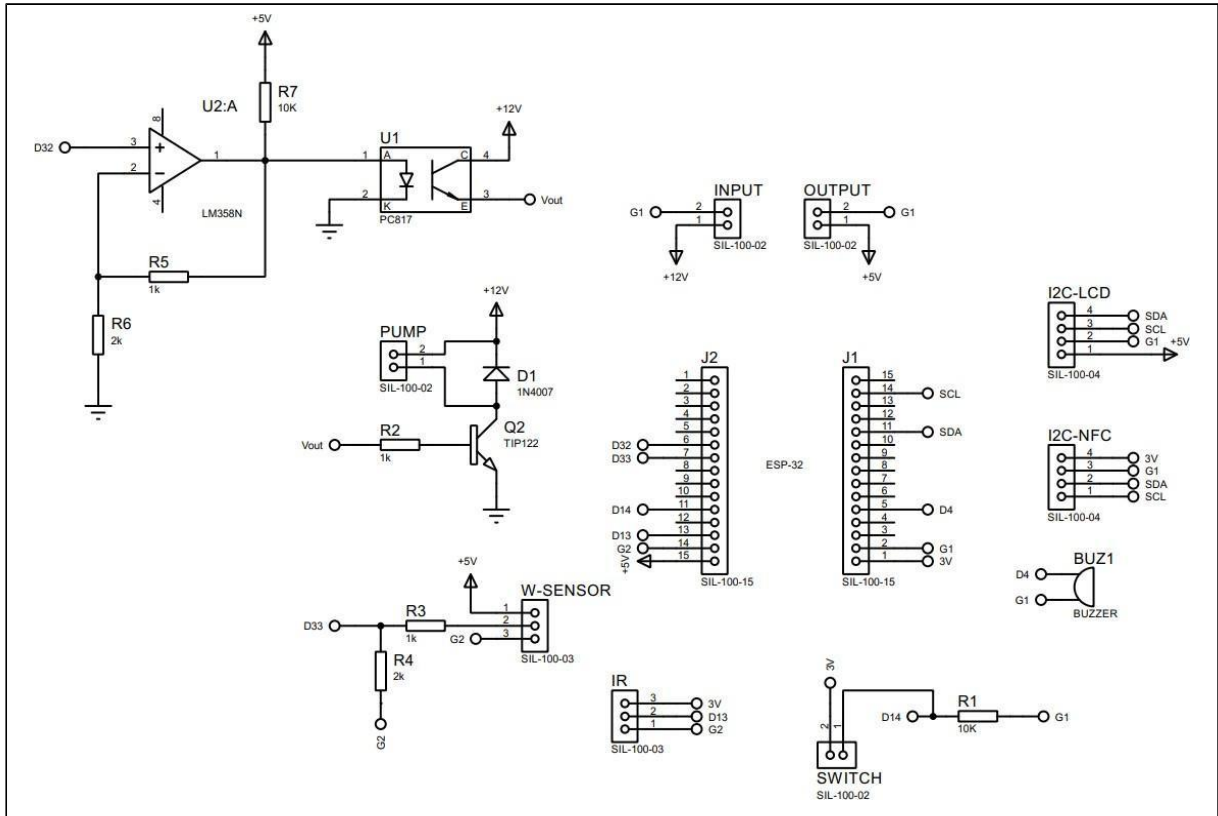

Figure 3.4: Schematic Diagram of E-zdey Petrol Pump Payment System via NFC Module

#### 4.0 RESULTS

The petrol pump payment mechanism operates effectively, providing a user-friendly and secure experience. As a car arrives, the IR sensor recognizes its presence and initiates the transaction procedure. As illustrated in **Figure 4.1**, users must tap their phones to the NFC receiver to establish a secure connection with the system. Prior to use, the dedicated application must be installed and configured on the user's phone for system interaction.

The process for setting up the application and starting fueling using the NFC payment method is depicted in **Figure 4.2**. Upon initiation, the user enters the required fuel quantity and approves the transaction using the installed application. The PN532 NFC module enables the system to receive and securely process transaction details, such as cost and volume. The ESP32 microcontroller serves as the central processing unit, managing the data exchange between the application and the server.



Figure 4.1: Smartphone with NFC-enabled touch to the NFC receiver

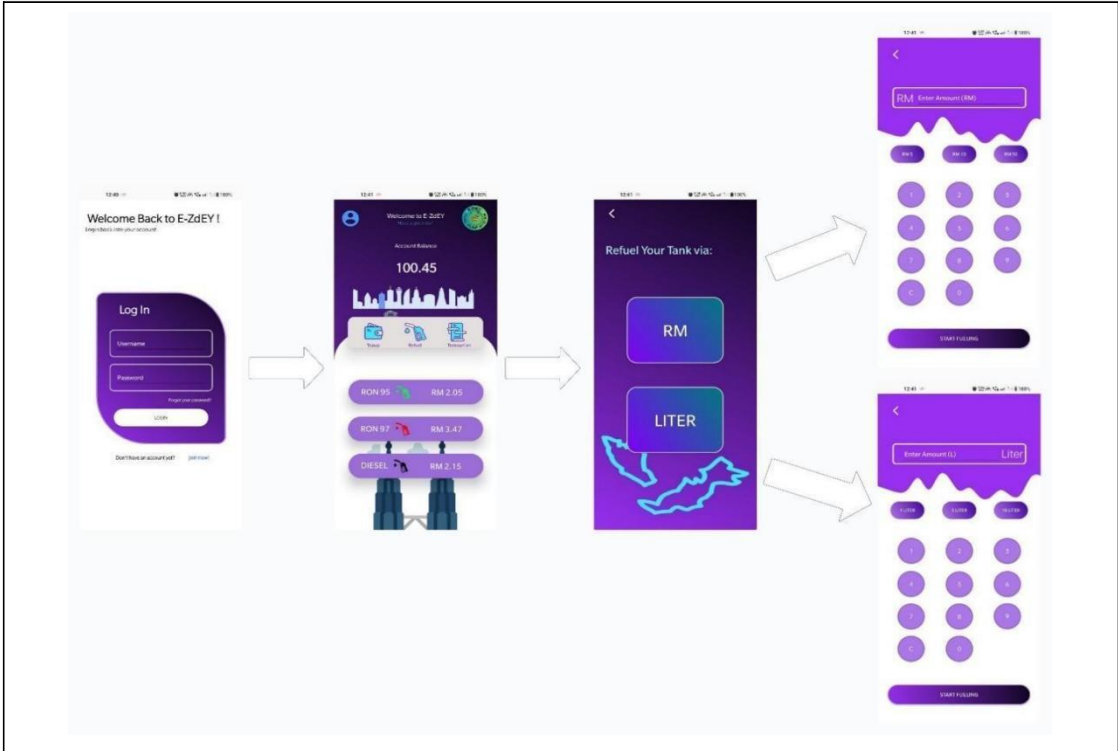

Figure 4.2: Application Interface The Ezdey App Interface

The server, in turn, examines the transaction information and returns the required data to the ESP32. The microprocessor commands the LCD to display the real-time flow rate meter, as seen in **Figures 4.3** and **Figure 4.4**. This provides users with quick feedback on transaction progress. Users can also view their transaction history in the program, displayed in **Figure 4.5**.



Figure 4.3: The LCD displays the target fuel flow rate by cost



Figure 4.4: The LCD displays the target fuel flow rate by liters

Transactions		
2024-01-07 06:55:53	Fuel Transaction RON 95	RM 5.00
2024-01-07 06:41:03	Fuel Transaction RON 95	RM 5.00
2024-01-07 06:38:17	Fuel Transaction RON 95	RM 5.00
2024-01-07 06:37:44	Fuel Transaction RON 95	RM 1.00
2024-01-07 06:35:05	Fuel Transaction RON 95	RM 5.00
2024-01-07 06:31:34	Fuel Transaction RON 95	RM 3.00
2024-01-07 06:30:36	Fuel Transaction RON 95	RM 5.00
2024-01-07 06:25:31	Fuel Transaction RON 95	RM 5.00
2024-01-07 06:22:57	Fuel Transaction RON 95	RM 3.00
2024-01-07 06:20:33	Fuel Transaction RON 95	RM 2.00

Figure 4.5: Transaction history in the application database

As illustrated in **Figure 4.6**, a strategically placed switch activates the fuel distribution motor at the nozzle. When users click the fuelling button, the motor starts and the LCD displays the current flow rate as portrayed in **Figure 4.7**. As shown in **Figure 4.8**, the motor comes to an automatic halt when it reaches the predefined target cost or liter, indicating that the fuelling process is complete.

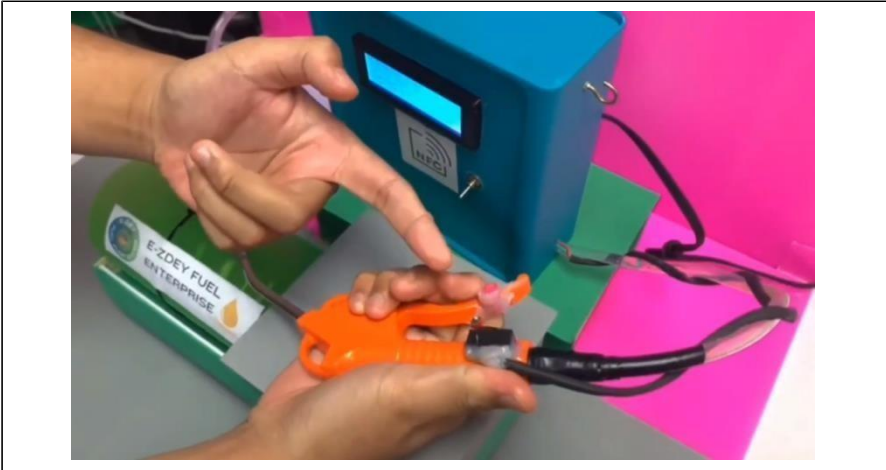

Figure 4.6: Activation motor switch



Figure 4.7: Start Fuelling process



Figure 4.8: LCD displays that the value has reached its target

## 5.0 CONCLUSION

E-ZDEY Petrol Pump Payment System via NFC Module, as demonstrated in this project, is a successful combination of novel hardware and software solutions. The transition from breadboard prototyping to creating a Printed Circuit Board (PCB) demonstrated the hardware components' commitment to dependability and scalability. Simultaneously, the software component, developed with Android Studio and Kotlin, demonstrated a user-friendly application that could be easily integrated with a MySQL database and a dedicated server.

This project achieved its goals by concentrating on security, efficiency, scalability and sustainability in fuel pump transactions. The iterative development process guaranteed continuous progress, resulting in a robust system capable of facilitating secure and quick transactions at petrol stations. This study not only provides a genuine solution to the problems with petrol payment methods, but it also contributes important insights to the evolving landscape of payment technologies. The successful deployment is an important step toward improving traditional gasoline transactions and satisfying the rising need for secure, efficient, and user-friendly solutions.

## REFERENCES

- [1] P. S. Josephng, J. H. Wong, and K. Y. Phan, "Post Covid19 Mobile NFC Payment," 2023, doi: 10.20944/preprints202303.0233.v1.
- [2] Y. S. Lee, Eun-Kim, S. J. Kim, and M. S. Jung, "Efficient mobile payment system using a near field communication (NFC)," in *Applied Mechanics and Materials*, Trans Tech Publications Ltd, 2013, pp. 2785–2791. doi: 10.4028/www.scientific.net/AMM.263-266.2785.
- [3] W. Chi Ying and M. K. Ismail Pakir Mohamed, "Understanding the Factors Influences Users Continuous Intention Towards E-Wallet in Malaysia: Identifying the Gap," *Research in Management of Technology and Business*, vol. 1, no. 1, pp. 312–325, 2020, doi: 10.30880/rmtb.2020.01.01.025.
- [4] A. Tewari and P. Singh, "Android App Development: A Review," *Journal of Management and Service Science*, vol. 01, no. 006, pp. 1–6, 2021, doi: 10.54060/JMSS/001.02.006.
- [5] A. Husen Shah, A. Ninad Soundankar, A. Muktar Shaikh, A. Niyajoddin Shaikh, and C. R. Ghuge, "Android Based E-Wallet Canteen Billing System."

**APPENDIX**

**GOLD Award Recognition Received from 9th EESEE2023**

