



UNIVERSITI
TEKNOLOGI
MARA



2023

JII CaS

**JOHOR
INNOVATION
INVENTION
COMPETITION
AND
SYMPOSIUM
2023**



"Innovation Inspires a Society
to be Critical and Creative"

JOHOR INNOVATION INVENTION COMPETITION AND SYMPOSIUM 2023



JOHOR INNOVATION INVENTION COMPETITION AND SYMPOSIUM 2023

"Innovation Inspires a Society to be
Critical and Creative"

Editors-in-Chief

**AHMAD KHUDZAIRI KHALID
NUR INTAN SYAFINAZ AHMAD**



الجامعة
UNIVERSITI
TEKNOLOGI
MARA

**Cawangan Johor
Kampus Pasir Gudang**

2023



First Edition 2023

Copyright © 2023 Universiti Teknologi MARA Cawangan Johor, Kampus Pasir Gudang.

All extended abstracts published in this e-book have not been subject to JIICaS2023 peer review or check. The authors are responsible for the contents of their extended abstracts and warrant that their extended abstract is original, has not been previously published, and has not been simultaneously submitted elsewhere. The views expressed in the abstracts in this publication are those of the individual authors and are not necessarily shared by the editor.

All rights reserved. No part of this publication may be reproduced in any form or by electronic or mechanical means, including information storage and retrieval systems, or transmitted in any form or by any means, without the prior permission in writing from the Course Coordinator of College of Computing, Informatics and Mathematics, Universiti Teknologi MARA Cawangan Johor, Kampus Pasir Gudang.

e ISBN: 978-967-0033-17-4

**Editors-in-Chief: AHMAD KHUDZAIRI KHALID &
NUR INTAN SYAFINAZ AHMAD**

**Art & Cover Designer: DR. WAN MUNIRAH WAN MOHAMAD
& DR. NUR IDAYU ALIMON**

**Published in Malaysia by
Universiti Teknologi MARA Cawangan Johor
Kampus Pasir Gudang
81750 Masai**





Preface

In the name of Allah, the Almighty who gives us the enlightenment, the truth, the knowledge and with regards to Prophet Muhammad (peace be upon him) for guiding us to the straight path. We thank to Allah for giving us guidance and strength to write this e-book.

This e-book compiles the extended abstracts that submitted to Johor Innovation Invention Competition and Symposium 2023 (JIICaS2023), where JIICaS2023 is a virtual platform for all creative minds to share and present their invention and innovation. The extended abstracts are divided into two categories, which are Category A (Higher Educational Student/ Any Recognized Institutional Students in Malaysia) and Category B (Primary/ Secondary School Students / Special Education School Students in Johor). Each abstract gives a brief background on the innovation or project.

We hope that this e-book will help the readers to get to know the innovation done by the students from both categories and get some ideas to develop future innovation products.



DEVELOPMENT OF AN IMPROVED CAMPING FIRE PIT

Norhanifah, A.R¹, Siti Amirah, A.S.B¹, Matzaini, K¹, Rusyidah Nabihah, R¹, Nur Aliah Afifah, M.S¹

¹School of Mechanical Engineering, College of Engineering, Universiti Teknologi MARA, Cawangan Terengganu, Kampus Bukit Besi, 23200 Bukit Besi, Dungun, Terengganu.

norhanifah@uitm.edu.my

ABSTRACT

The camping fire pit is an important piece of equipment for camping activity especially at night because the main usage is to light a fire that can warm the body. However, there are lots of campers who burn their fuel, such as charcoal and wood, on the ground, which will cause harm to the environment. Hence, this study is to design a portable and foldable camping fire pit that can be packed and transported easily using a mechanical engineering design process. The modeling for this product will be developed using SolidWorks software. In addition, this product is specially designed with a suitable shape, is easy to install, and hence can be carried anywhere. This fire pit also has a feature with a container that can return the fuel used. At the end of the study, this product will present a convenient and useful functionality that will help users with camping activities. At the same time, it is also environmentally friendly.

Keywords: Camping fire pit, SolidWork software, Mechanical Engineering Design Process.

1.0 INTRODUCTION

Nowadays, outdoor activities such as picnics and camping have become popular, especially among teenagers and families. Camping has many benefits for everyone, old or young, and families can enjoy it outdoors or indoors. For example, camping can help us build and strengthen relationships. In addition, camping can give a better sleep quality because the only alarm clocks are the sun and birds chirping. Therefore, it is important to have proper and essential camping gear and accessories for a comfortable and safe experience while doing the activities. One of the essential camping gear for campers is a fire pit. This fire pit is important since it is often used as a bonfire to warm the body at night, and it can be an outdoor pest control that repels flying insects such as mosquitoes and bugs. But at the same time, camping fire pit can bring bad effect to environment [1].

2.0 OBJECTIVE

The objective of this project is to design an improved camping fire pit using a mechanical engineering design process and SolidWorks software.

3.0 DESCRIPTION OF INNOVATION/METHODOLOGY

This method includes a systematic approach to the engineering design process.

3.1 Flowchart of The Design Process

This flow chart can be used to define and analyse a process, build a step-by-step picture of it, and then standardize or improve it.

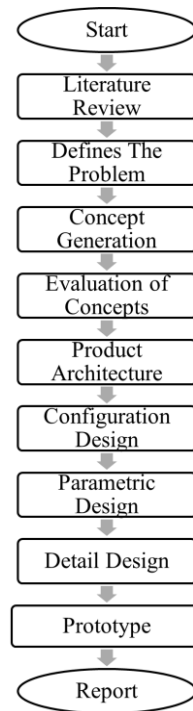

Figure 1: Flowchart of The Design Process

3.2 Concept Generation

Morphological tables can be used to analyse various methods and combinations of obtaining functionality and to visually represent the functionality that a product must have. The Morphological Table for this study is shown in Table 1.

Table 1: Morphological Table for an Improved Camping Fire Pit

| Sub-function | Option-solution |
|--------------------|---|
| Handle | A1 U-shaped handle |
| | A2 Finger-shaped handle |
| | A3 Straight handle |
| Type of Stand Base | B1 Stainless steel collapsible frame base |
| | B2 Round base |
| | B3 Square base |
| Types of Grill Net | C1 Stainless steel fire net |
| | C2 Circle fire net |
| | C3 Square fire net |
| Body Windshield | D1 Portable pieces windshield |
| | D2 Circle windshield |
| | D3 Square windshield |
| Storage box | E1 Square box |

The combination of option-solution for the final three (3) concepts is shown in Table 4. The first concept, the camping fire pit, easy to install and portable. For the second and third concept

is not portable and beyond the space. The first concept has a storage box, so it is easy to store excess fuel while the second and third concepts do not have a storage box.

Table 2: Generation of Concept for an Improved Camping Fire Pit

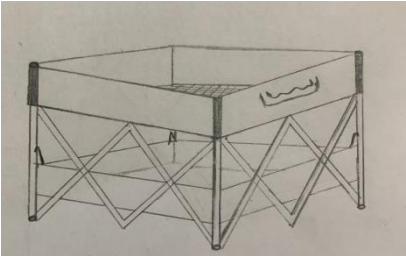
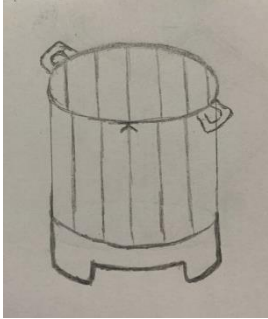
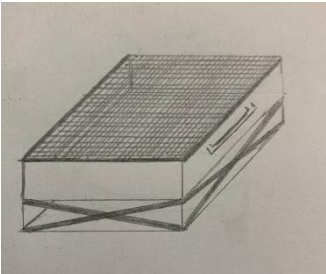
| Concept | 1 | 2 | 3 |
|--------------------------|---|--|---|
| | A1 + B2 + C1 + D1 + E1 | A2 + B2 + C2 + D2 | A3 + B3 + C3 + D3 |
| Selected Option-Solution |  |  |  |
| Figure | | | |

3.3 Concept Selection

Pugh table is a method for comparing various options and identifying the best one because it aids in decision-making, it is also known as a decision-making matrix or decision-matrix process. The Pugh Table for this study is shown in Table 3.

Table 3: Pugh Table of an Improved Camping Fire Pit

| Criteria | Weight | Datum | Concept 1 | Concept 2 | Concept 3 |
|-------------|--------|-------|-----------|-----------|-----------|
| Cheap | 4 | 0 | + | + | + |
| Weight | 5 | 0 | + | + | + |
| Ergonomic | 4 | 0 | + | 0 | + |
| Safety | 5 | 0 | 0 | 0 | - |
| Reliability | 5 | 0 | + | 0 | 0 |
| Performance | 4 | 0 | 0 | - | - |
| Appearance | 3 | 0 | + | 0 | 0 |
| | | + | 21 | 9 | 13 |
| | | - | 0 | 4 | 9 |
| | | Total | 21 | 5 | 4 |

Based on this Pugh Table, concept 1 is selected because it has advantages in terms of reliability, performance and appearance when compare to others concepts and excel well in terms of cost, weight, ergonomic when compared to reference product.

3.4 Detail Design

Figure 2 shows the assembly drawings of the fire pit concept 1. The design model was developed using SolidWorks software.

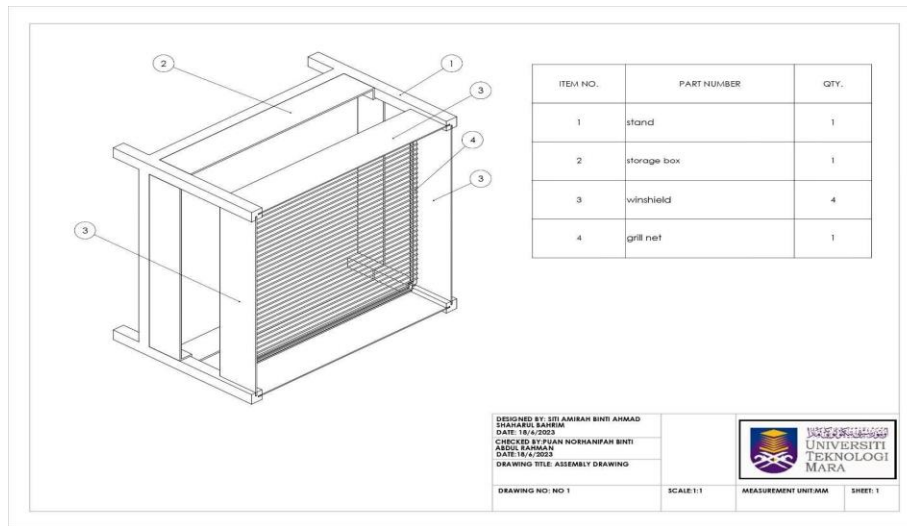

Figure 2: Assembly Drawing of Camping Fire Pit

4.0 ADVANTAGE/IMPACT/RESULTS/NOVELTY

There are several advantages of this camping fire pit product, especially in the first concept. This fire pit can make it easier for users to light a fire. In addition, this camping fire pit also has a special place for excess fuel that has been used, therefore it can save the cost of fuel consumption.

5.0 CONCLUSION

In conclusion, Concept 1 has been selected as the preferred choice, meeting the criteria of reliability, performance, and appearance compared to other concepts. Furthermore, it excels in terms of cost, weight, and ergonomics when compared to the reference product. This confirms that Concept 1 is the most suitable option for designing an improved camping fire pit, successfully achieving the project's objectives.

REFERENCE

[1] "Are Fire Pits Bad for the Environment?," Fire Pit Art®. <https://www.firepitart.com/firepitart.com/blog/are-firepits-bad-for-environment>