

FIRM CHARACTERISTICS, DEMAND FOR EXTERNAL AUDITING SERVICES AND FINANCIAL PERFORMANCE: AN EMPIRICAL STUDY ON COOPERATIVE ENTERPRISES IN EAST JAVA, INDONESIA

Oyong Lisa¹
Grahita Chandrarin²
Edi Subiyantoro²

¹STIE Widya Gama Lumajang, Indonesia

²University Merdeka, Malang, Indonesia

ABSTRACT

The purpose of this study is to examine the effects of firm characteristics (consisting of members, cooperative scale and liabilities) on the demand for external auditing services and their implications on financial performance. This study uses secondary data collected from the Department of Small and Medium Enterprises and Cooperatives in East Java Province and then analysed using path analysis. Results showed that the effect of firm characteristics consisting only of members and cooperative scale is statistically significant on requests for external audit services. They also showed that the effect of firm characteristics in terms of liabilities and the demand for external auditing services is statistically significant on financial performance, indicating that the number of cooperative members determines the voluntary requests for external audit services. Cooperatives with large numbers of members tend to request for external auditing services. Large-scale cooperatives will increase the volume of transactions, which may cause errors in financial data and statements that will lead to requests for external auditing services. These requests are done to obtain accurate information. The agency theory indicates that cooperation with great amounts of liabilities has to show better performance because activities are monitored by stakeholders. In this case, financial reports are important in forming business decisions.

Keywords: members, cooperative scale, debt, demand for external auditing service, financial performance.

INTRODUCTION

This study examines the effects of firm characteristics (consisting of members, cooperative scale and liabilities) on the demand for external auditing services and their implications on financial performance. This study is conducted on cooperatives in East Java Province, Indonesia. A cooperative is a business entity consisting of a group of people or a legal entity that work together based on cooperative principles and the laws of economics to improve the prosperity of its members. According to Ropke (1987), the main characteristic of cooperatives that distinguishes it from other business entities is the dual identity of the member, both as owner and user (owner-user-oriented firm).

Many factors affect external auditing services. Guyetal. (2001:5) stated four factors that lead to the demand for external auditing services, including (1) complexity, (2) distance, (3) bias and motive presenters and (4) consequences. Carey et al. (2000) explained that demand for auditing services increase by decreasing the control or supervision of ownership. Chow (1982), Tauringana and Clarke (2000) and Susilowati (2001) stated that demand for external auditing services was also carried out by a company with a relatively large size, has a larger proportion of debt in the capital structure. They also found that the percentage of company shares held by managers is smaller than that occupied by other parties. Several studies have focused on the factors that affect a business entity requesting for external auditing services. Inconsistencies exist between the results these previous studies. Chow (1982) described the factors that influence the demand for external auditing services, which include firm size, total debt and proportion of ownership. Tauringana and Clarke (2000) suggested that factors that influence the demand for external auditing services of small firms include size (turnover), ownership influences and gearing, whereas size (total assets) and liquidity ratio do not affect the request for external auditing services. Welter et al. (2001) explained the need for independent external auditing or auditing of financial statements because of four conditions, namely, differences in interests (conflict of interest), consequence, complete trouble and effort (complexity) and control (remoteness). Susilowati (2001) also conducted a study similar to that of Chow (1982), and stated that firm size, proportion of ownership and leverage ratio affect the demand for external auditing services. Sumanto (2003), whose study focused on private

companies in East Java, found that company size, leverage and management perceptions affect the demand for external auditing services, whereas the proportion of share ownership by management does not affect the demand for external auditing services.

Inconsistencies exist in the results of many studies such as in terms of the effect of firm size on the demand for external auditing services, as found by Carey et al. (2000) whose study differed from that of Chow (1982), Tauringana and Clarke (2000), Susilowati (2001) and Sumanto (2003). They stated that firm size affects the demand for external auditing services. In terms of proportion of ownership, Chow (1982), Tauringana and Clarke (2000) and Susilowati (2001) stated that ownership affects the demand for external auditing services, whereas Sumanto (2003) suggested otherwise. Based on these arguments, this study is important in investigating the demand for external auditing services. This study extends the study conducted by Carey et al. (2000), and focuses on the effects of firm characteristics (consisting of members, cooperative scale and liabilities) on the demand for external audit and their implications on financial performance.

The objects in this study are cooperatives as enterprises in East Java Province because of the increase in the demand for external auditing services on cooperatives, whereas the reasons for requesting external auditing services pertain to the independence and professionalism in the management of the company. This study takes the research area by selecting a population of cooperative enterprises in Indonesia. The samples were taken from East Java Province because of the large number of cooperatives there: 28,774 out of the 188,181 cooperatives in Indonesia. Firm size of cooperatives in East Java (many have large assets) is IDR 23,836,095.70. Thus, cooperatives in East Java represent all cooperative enterprises in Indonesia.

LITERATURE REVIEW AND HYPOTHESIS DEVELOPMENT

In terms of decision-making, information users are more likely to trust information from audited financial statements. Reasons for increasingly unreliable information are as follows: (1) no close relationship between the recipient and provider of information, (2) partiality and other motives

of the information provider; (3) excessive data, which may result from an increase in the size of an organization that led to an increased number of business transactions and (4) complexity of transaction exchange. In modern times, obtaining information on decision-makers by direct business partners is almost impossible. Business partners must be satisfied with the information provided by the other party. Information obtained directly from the first party, either intentionally or otherwise, tends to be correct. If the information is presented by parties who have different objectives than the aim of decision-making, then the information is likely to favour the presenter of information, which also increases the possibility of carrying incorrect information in the books because of overlapping interests. The increasing complexity of inter-company transactions raises the difficulty of recording information properly.

Chow (1982) explained that factors that influence the demand for external auditing services are firm size, total debt and proportion of ownership (ownership influences), whereas Tauringana and Clarke (2000) suggested that factors that influence the demand for external auditing services in small firms include size (turnover), managerial share ownership and gearing. Meanwhile, size (total assets) and liquidity ratio do not affect the demand for external auditing services. Susilowati (2001) conducted a study similar to that of Chow (1982). His study analysed the perception of private companies in Central Java on the request for auditing services, where the factors that affect company size include the proportion of ownership and leverage ratio. A study similar to that of Susilowati (2001) is that by Sumanto (2003), who focused on private companies in East Java. The results of the study of Sumanto (2003) indicated that the amount of companies, leverage and management perceptions affect external auditing services, whereas the proportion of share ownership by management does not affect the request for external auditing services. This finding is in contrast with the results of Susilowati (2001), who stated that the proportion of ownership affects the demand for external auditing services.

Carey et al. (2000) conducted a study on the demand for internal and external auditing in family businesses. The object of the study was a family company that was taken as a family firm, which has a major contribution in the country's economy. The study conducted on family firms is listed in the survey data of the Australian family company. The results obtained

Carey et al. (2000) indicated that the demand for internal and external auditing on the family firm is also influenced by the total debt and owner influences (proportion of non-family management and proportion of non-family representation on the board of directors), but size does not affect the company. This finding is contrary to the results obtained by Chow (1982), Tauringana and Clarke (2000), Susilowati (2001) and Sumanto (2003). Owner influence is measured based on the proportion of stock ownership. Chow (1982), Tauringana and Clarke (2000) and Susilowati (2001) all found that the proportion of share ownership by management affected the request for external audit services, whereas Sumanto (2003) indicated that the proportion of share ownership does not affect the demand for external auditing services. Carey et al. (2000) reported that owner influence, as measured by (1) the proportion of non-family management within the company and (2) the proportion of non-family representation on the board of commissioners, affects the demand for external auditing services.

Cooperatives possess the measurement tools for measuring the performance, both appraised in terms of financial and management aspects. They are regulated by the Minister Regulation of Cooperatives and Small Medium Enterprises (SMEs) Republic of Indonesia Number: 14/per/m.kukm/xii/2009 regarding the Changes of Minister Regulation of Cooperatives and Small Medium Enterprises and number 20/per/m.kukm/xi/2008 regarding the Guidelines for Assessment of Performance of Credit Unions and Savings and Loans Cooperative Unit. Many aspects and components are used to measure the performance of cooperatives, namely, (1) capital, (2) quality of productive assets, (3) management, (4) efficiency, (5) liquidity, (6) autonomy and growth and (7) identity of cooperative aspects.

The Effect of Firm Characteristics on the Demand for External Auditing Services

In this study, firm characteristics consist of members, cooperative scale and liabilities, and they are examined for their effects on the demand for external auditing services. Prior studies conducted by Chow (1982) and Nasir (1995) examined the effect of debt and ownership influences in a company. The results of those studies indicated that ownership influences the demand for external auditing services. The study of Indira (1998) found that the number of members negatively affect the demand for external auditing services, which could be because a large number of members do

not by themselves cause the cooperative to request for an audit because of their limited education and understanding of the audit itself. Carey et al. (2000) conducted an empirical study that identified the correlation between company size and the demand for external and internal auditing services. The literature suggests a number of theoretical explanations. Using the theory and results of previous studies, this study formulates the first set of hypotheses as follows:

H_{1a}: The effect of the number of members on the demand for external auditing services is statistically significant.

H_{1b}: The effect of cooperative scale on the demand for external auditing services is statistically significant.

H_{1c}: The effect of total liabilities on the demand for external auditing services is statistically significant.

The Effect of Firm Characteristics and the Demand for External Auditing on Financial Performance

Cooperative performance assessments were conducted using qualitative and quantitative approaches for at least one year through board meetings. The assessment results were submitted to the performance board members transparently through a circular or notice board for a maximum of one month service period for each committee to serve as board accountability to all members. The results of cooperative performance assessments reflect the actual conditions in accordance with the situation on the field. Research conducted by Bracker and Pearson (1990) indicated that managers of small companies have a disadvantage in managing their financial plans. Most of their weaknesses lie in the lack of ability to conduct analysis and statistical procedures, lack of unity of data and imprecision in measuring financial performance. Bracker and Pearson performed tests to observe if the role of financial consulting services should be improved by companies. A comparison of the financial performance of companies that use consultants with those that do not showed no significant difference between the performances of the two types of firms. Using the theory and the results of the prior study, this study formulates the second set of hypotheses as follows:

H_{2a}: The effect of the number of members on financial performance is statistically significant.

H_{2b}: The effect of cooperative scale on financial performance is statistically significant.

H_{2c}: The effect of total liabilities on financial performance is statistically significant.

The Effect of the Demand for External Auditing Services on Financial Performance

The demand for external auditing services creates financial reports that contain relatively valid information explaining the real conditions of economic activities carried out by the management company (agent). Bracker and Pearson (1990) found that managers of small companies have a disadvantage in managing their financial plans. Prasetyo (1999) examined the role of the independence level of auditors in cooperatives and concluded that the associated levels of auditor independence suggest cooperation. Yuhertiana and Sofyan (2007) showed that the supposed differences between the financial performance of cooperatives and that of certain cooperatives that do not use the services of a public accountant have not been proven. Using the theory and the results of previous studies, this study formulates the third hypothesis as follows:

H3: The effect of the demand for external auditing services on financial performance is statistically significant.

RESEARCH METHOD

Research Design

This study adopts the causal research design because it intends to examine the influence between variables. The study is called an explanatory research as it aims to explain the influence between the variables by testing the hypotheses (Malhotra 1999: 212-243). Three types of variables were used, including dependent, independent and intervening variables. The dependent variable is financial performance; the intervening variable is

the demand for external auditing services; and the independent variables are firm characteristics, consisting of members, cooperative scale and debt or liabilities.

Data and Sampling

The population in this study consisted of cooperative enterprises in East Java, amounting to 28,774. Sampling was performed through non-probabilities using the purposive sampling method. The samples of this study consisted of 120 cooperatives. This study used secondary data collected from the Department of SME and Cooperatives in East Java. Three hypotheses were examined using path analysis and divided by several sub-structures (sub-structures 1, 2 and 3).

Research Model

Using path analysis, the following figure shows the basic model of this study.

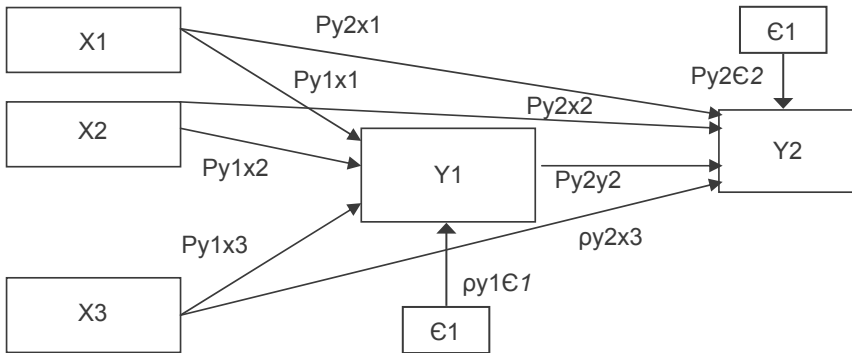

Figure1: Basic Model of the Study

The basic model of this study consists of three sub-structures, as mentioned in the statistics equations below.

Sub-structure 1: $Y1 = \rho_{01} + \rho_{y1x1} X1 + \rho_{y1x2} X2 + \rho_{y1x3} X3 + \epsilon_1$

Sub-structure 2: $Y2 = \rho_{02} + \rho_{y2x1} X1 + \rho_{y2x2} X2 + \rho_{y2x3} X3 + \epsilon_2$

Sub-structure 3: $Y2 = \rho_{03} + \rho_{y2y1} Y1 + \epsilon_3$

RESULTS AND DISCUSSION

The Effect of Firm Characteristics on the Demand for External Auditing Services

The following table shows the results of the analysis on the effects of firm characteristics on the demand for external auditing services.

Table 1: Results of Path Analysis of Sub-Structure 1

Variables	Coefficients of Beta	Std. Error	t value	p- value
Members	0.150	0.084	2.080	0.040*)
Cooperative scale	1.019	0.231	1.971	0.051*)
Debt	-0.392	0.196	-0.765	0.446

*) Statistically significant at level $\alpha = 5\%$

The results of the first hypothesis testing showed that the effects of firm characteristics consisting solely of members and cooperative scale on the demand for external auditing services is statistically significant, with a beta coefficient of 0.150 and a p value of 0.040 for members and a beta coefficient 1.019 and p value of 0.051 for cooperative scale. The effect of total debt or liabilities on the demand for external auditing services is not statistically significant, indicating that the number of cooperative members voluntarily determines the demand for external auditing services. Cooperatives with large numbers of members tend to request for external auditing services because large-scale cooperatives have higher volume of transactions. Members are individuals who are part of the cooperative in accordance with the requirements specified. As members of these cooperatives, they pay a sum of money for the principal and mandatory savings. In general, members of the cooperative have economic ties with the cooperative they enter. A closer economic relation between the members and the cooperative means a more likely development of the cooperative. Therefore, each member of the cooperative has obligations and rights. A larger number of members results in greater ability of a cooperative to cultivate or raise capital from its members. The capital of the cooperative will encourage the development of cooperative efforts. With the development of co-operatives not ruling out greater problems of mistrust towards the performance of board members, cooperative members can be either active or passive. Active members hope to obtain more information on the development of financial and cooperative

efforts, whereas passive cooperative members will have little information on the development of cooperative business and finance. The board also has interests on those involved in the cooperative management, which further increases cooperative efforts but also brings out selfish motives. Auditing financial statements becomes necessary to overcome this issue. Financial statement auditing can be conducted either by internal or external parties. According to Haron et al. (2004) a relationship exists between internal and external audits, such that external auditors usually have confidence in internal audits conducted by the business entity. Despite this confidence, external audits should still be performed. Carey et al. (2000) found that the number of members is a factor that determines the demand for voluntary internal or external auditing. Increased membership in a cooperative is an indicator of its success. The addition of indirect cooperative members results in an increase in the size of the cooperative. However, the addition of a cooperative member in a local capacity to the cooperative serves its members because if the cooperative can grow and have members but it does not provide cooperative services to its members, then the cooperative does not function. The results are consistent with those of Januarti and Nasir (2006) and Nasir (1995) but are inconsistent with those of Indira (1998).

The results of the analysis show that cooperative scale significantly influences the demand for external auditing services. The result is in contrast to those of Januarti and Nasir (2006) who reported that cooperative scale does not affect the demand for auditing. The effect of cooperative scale on the demand for external auditing services is very significant because large-scale cooperatives undergo an expected increase in the volume of transactions and errors may occur in its accounting data and financial statements. This significance is the reason for the need for an independent external auditor to test financial statements. These independent external auditors should be competent and possess expertise in understanding the corporate entity, transaction–transaction accounting and accounting systems. These results are consistent with those obtained by Carey et al. (2000) and Tauringana and Clarke (2000). Cooperative scale also depends on the number of members in the cooperative because cooperative members share the same responsibility of having to pay the principal savings deposits and liabilities required to participate actively. This responsibility ensures that the cooperative effort to increase the number of members also improves, such that cooperative scale has an effect on the demand for external auditing services.

The double identity of cooperative members is the main characteristic that distinguishes cooperatives from other business entities. Cooperative members act as both owners and users of the cooperative. Members have no influence on financial performance as active and passive members both participate in the business activities of the cooperative, that is, the roles of active and passive members in participating, contributing and monitoring the performance of cooperatives are not balanced. The cooperative formed by a group of people who manage the company is tasked jointly to support the economic activities of individual members, which suggests that a measure of the success of cooperatives depends on its members, as shown by the addition of cooperative members. The addition of indirect cooperative members could be massive, but the addition of a member to the cooperative in a local capacity serves its members because if the ability of the cooperative to increase its membership is not accompanied by the ability to provide cooperative services to its members, then its functions are not performed correctly. Principles contained in Act No.25/1992 Article 5 paragraph 1 mention that cooperative management should be done democratically and with the principle that one member is entitled to one vote. Therefore, if members of the cooperative increase, then the differences in interest also increase and the voice or desires of members encourage better performance in the cooperative. However, if this increase is not balanced with good participation, then no performance improvements is likely to occur, including those improvements concerning the quality of human resources of members with a low level of education and others.

The Effects of Firm Characteristics and the Demand for External Auditing Services on Financial Performance

The following table shows the result of the analysis on the effects of firm characteristics on the demand for external auditing services and their implications on financial performance.

Table 2: Results of Path Analysis for Sub-Structures 2 and 3

Variables	Coefficients of Beta	Std. Error	t value	p-value
Member	0.081	0.008	1.186	0.328
Cooperative scale	-1.138	0.022	-2.321	0.022*)
Debt	1.329	0.018	2.778	0.006*)
Demand for External Auditing	0.574	0.009	6.626	0.000*)

*) Statistically significant at level $\alpha = 5\%$

Table 2 shows the results of the second hypotheses testing and indicate that the effects of firm characteristics consisting of members and cooperative scale are not statistically significant on financial performance. The effect of total liabilities on financial performance is statistically significant, with a beta coefficient of 0.235 and a p value of 0.006, which means that only liabilities directly affect financial performance.

The results of this study show that members are significantly positive on the financial performance through audit requests. The intention is to influence the members of the cooperative to perform financially, such that more members mean more capital-managed cooperatives and that cooperative members are also influenced by the increase of capital in accordance with their obligations when the cooperative must pay its principal. The amount shall be the same for all members, and increasing number of members who serve the growing accretion will increase the turnover and profitability of the cooperative. However, increasing the number of members could results in new problems because of an increase in transactions. Turning over the performance of the board and managers can assure members that the report is true, and that the performance requires external auditing services. This finding supports the results obtained by Djumahir et al., (2002) who found that members have a significant effect on financial performance.

Cooperatives provide economic benefits to their members directly or indirectly. Direct economic benefits are those received by the members in the form of profitable prices and favourable interests, whereas the indirect economic benefits are in the form of the balance of the value received by members. Direct economic benefits are gained when members perform with the cooperative transaction processing, whereas indirect economic benefits are gained at the end of the fiscal year by service members using

existing goods and services in the cooperative. The existence of economic benefits to members of the cooperative will provide micro and macro effects. The micro effect increases cooperative services for businesses and group events or members of the household economy (both as consumers and producers), whereas the macro effect of development is in the form of a cooperative organisation capable of increasing the income and welfare of its members and their environment. The existence and development of true cooperatives can provide major benefits for members in the form of business flow, household economic stability, meeting the needs of members, production marketing, input procurement and production facilities with stable and adequate prices.

Total liabilities significantly influence financial performance because the development of cooperative assets from an increased liability will encourage capital or financial institutions, thereby increasing the effect on the members. Their needs can be met, which in turn will result in increased profitability and liquidity, thereby improving its financial performance or making it independent when viewed from the capital adequacy ratio and liquidity and profitability ratios. The results of this study differ from that of Djumahir et al. (2001) who report that the obligation or debt cannot measure whether the level of performance is good because the performance still needs to be proved by the interest rate to be paid. This difference occurs from the point of view of the research by Djumahir et al. that investigated only from the perspective of the obligation to pay interest on the loan, whereas this current study found several changes related to the addition of assets in debt or obligation. A greater amount of liabilities resulted in better performance of these institutions because all work plans can be met generally. The acquisition of debt is already planned, specifically as to the amount of money that should be added through debt both in the short and long terms, with respect to the level of costs that would arise from dependent obligations.

Effects of the Demand for External Auditing Services on Financial Performance

The result of the third hypothesis testing showed that the effect of the request for external auditing services on financial performance is statistically significant, with a beta coefficient of 0.538 and a p value of 0.000. Firm characteristics consisting of members and cooperative scale do not directly

affect financial performance (but through external audit services) and that only liabilities directly affect financial performance. Hence, external auditing services are an intervening variable between firm characteristics that consist of members and cooperative scale and financial performance.

Financial statements provide information regarding the financial position, performance and changes in financial position and show the accomplishments of the management or the accountability of the management for resources entrusted to them. Cooperative financial statements prepared under GAAP would enable the information presented to be more easily understood, relevant and reliable. Conversely, if the cooperative financial statements are prepared based on the wrong standards and principles, then it may mislead users. Financial statements should contain the truth, and is the reason for adopting an adequate accounting system. An essential of financial management in any business is creating a proper financial statement. The financial report should be created by an individual who understands the books, or an accountant from the cooperative who could also enlist the help of outside accountants following analysis. Ensuring further accuracy by placing accountants under the supervision of the cooperative supervisor is a good step, as this could ensure that deviations are easily found, and interested parties can assess the business and financial conditions of the cooperative

The financial information is presented in beneficial cooperative accounting to various directly or indirectly interested parties. For members of the cooperative, owners should be interested to learn of the information presented by cooperative accounting, including determining the development of cooperative capital, the amount of profit or net income earned the value that would be obtained by cooperatives in the future. The demand for external auditing services significantly influences financial performance, which suggests that the need for financial reports could be considered important in making a decision. Financial statements need to be audited because of the differences in the interests between the users of financial statements and the management responsible for its preparation. Financial statements play an important role in decision-making by financial statement users. The general objective of the audit of financial statements is to provide a statement of opinion on whether the financial statements presented are fairly examined and consider all material aspects, indicating that everything is in accordance with the accounting principles that determine the overall

condition of the company. Financial statements are used as a basis for development and planning, particularly the improvement of working conditions and the quality of performance. These statements are also created for the management to become aware of the strengths and weaknesses of the company in order to improve its development, to be better acquainted with the circumstances and skills of its employees on a regular basis as well as to encourage healthy reciprocity between superiors and subordinates.

The existence of financial management by the management raises two distinct interests: the interests of managers in the board and those of the owners. Agency theory reveals that the management company is willing to take responsibility for the management of the external funds, but the other parties outside the company may wish to obtain reliable and trustworthy information on the management of the funds invested. An important quality of the information collected in the financial statements is the simplicity that makes it immediately understood by the user. For this purpose, users are assumed to have adequate knowledge of business and economic activities and accounting, and should be willing to study the information with reasonable diligence. Information must be relevant to meet the needs of the users in the decision-making process. Having relevant information may affect the quality of economic decisions because it could aid managers in evaluating user events in the past, present or future and asserts or corrects the evaluation of the manager in the past. The information must be reliable in order to be useful. Quality information is reliable if it is free from misleading and material errors, and is reliably presented (faithful representation), of which should have been served or that are reasonably expected to be presented. Financial statement users should compare financial statements between periods to identify trend positions and financial performance. Users should also compare the financial statements to evaluate the inter-cooperative financial position, performance and changes in the relative financial position.

The results are consistent with those obtained Prasad (1999), who provided suggestions related to the level of independence of auditors in cooperatives. Yuhertiana and Donny (2007) found no difference between the financial performance of cooperatives and use of KAP services that do not use the services of the firm from the Village Unit Cooperatives, which has existed since Banyuwangi in 1999. These results also differ from the findings

of Bracker and Pearson (1999), who determined no difference in the performance of managers in companies that use and do not use the financial services of a consultant.

The influence of members on financial performance through audit requests is significantly positive. This result is consistent with the hypothesis that the effect of members on financial performance is positive but using a moderate factor or reinforcing the external audit requests. The results of this study highlight that the number of members will influence financial performance, such that more members will result in more capital-managed cooperatives, and that cooperative members are also influenced by the increase of capital in accordance with the obligations they entered into when the cooperative must pay the principal and when each member mandatorily pays the same amount. This statement is made with the increase in members who served the growing accretion and will increase the turnover and profitability of the cooperative. However, more members will bring new problems because of an increase in transactions. Later, turning over the performance of the board and the managers can assure the members that the report is true, and therefore, the performance requires external auditing services. This finding supports the research done by Djumahir et al., (2002) who state that members have a significant effect on financial performance.

The effect of cooperative scale on financial performance through the demand for external auditing services is significant, implying that the size of the assets of the cooperative greatly affects financial performance in a positive or negative manner. The asset intent of these findings is small; the needs of the service member will certainly not be optimal because of limited facilities and capital and human resources. However, when a major asset liquidity is also significant, facilities and capital facilities will also be considerable, and the needs of the members of the cooperative can be served at any time within the course of maximum service, which will affect the development of cooperatives. Cooperative human resources would be better qualified in ensuring availability of performance reports. In the end, a large or small scale will affect the validity of the financial performance and required reports. Therefore, the role of external auditing services is necessary to check whether the performance is good, which is also why the demand for external auditing services is a variable scale cooperative reinforcement in relation to performance finance. This study supports the theory that if assets

increase, then they could result in increased profits. Otherwise, our findings are inconsistent with that of Djumahir et al. (2001), who established that assets have no significant effects on financial performance.

Effects of Firm Characteristics on the Demand for External Auditing Services and their Implications on Financial Performance

The results of the path analysis are shown in Figure 2.

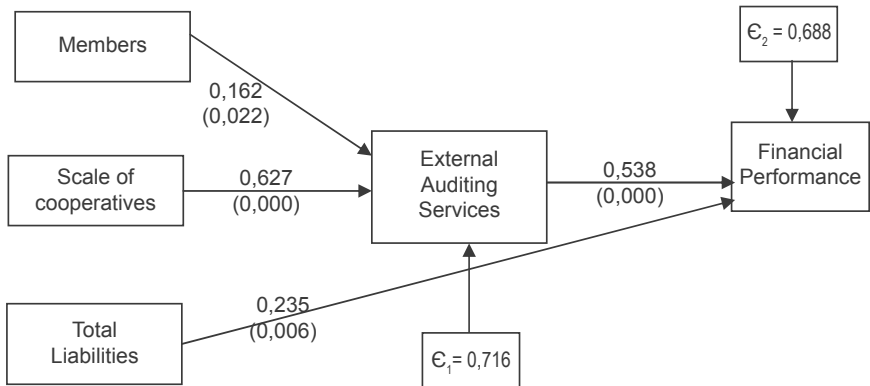

Figure 2: Final Model of Path Analysis Results

Based on the final model shown in the figure above, the following table summarises the results of the hypothesis testing. The rule of thumb is that if the value of the beta coefficient occurs with a p-value equal or less than 0.05, then the hypothesis is statistically significant at level $\alpha = 5\%$. A summary of the results of the final model is shown in Table 3.

Table 3: Hypothesis Testing Results Based on Final Model

Variables	Coefficient of beta	pValue
Member	0.162	0.022*
Scale Cooperative	0.627	0.000*
Member	0.046	0.501
Total liabilities	0.235	0.006*
Demand for external auditing services	0.538	0.000*

*Statistically significant at level $\alpha = 5\%$

The results of the first hypotheses testing illustrated that the effect of firm characteristics consisting of only members and cooperative scale on the demand for external auditing services is statistically significant, with a beta coefficient of 0.162 and a p value of 0.022 for members and a beta coefficient of 0.627 and a p value of 0.000 for cooperative scale. The effect of total liabilities on the demand for external auditing services is statistically significant, but does not directly affect financial performance. The effects of debt and demand for external auditing services on financial performance are statistically significant, which means that debt directly affects financial performance.

CONCLUSIONS AND RECOMMENDATIONS

This study examined the effects of firm characteristics (consisting of members, cooperative scale and liabilities) on the demand for external auditing services and their implications on financial performance. The results of the data analysis conducted under path analysis indicated that the effects of firm characteristics consisting only of members and cooperative scale on the demand for external auditing services are statistically significant. They also indicated that the effects of firm characteristics in terms of debt or liabilities and the demand for external auditing services on financial performance are statistically significant.

Members have a significant effect on the demand for external auditing services. The results are consistent with those of Carey et al. (2000). The number of members is a factor that led to the voluntary convening of an internal or external audit. This result is consistent with those obtained by Januarti and Nasir (2006), who report that a significant number of members affect audit requests. The results of this study are inconsistent with those obtained by Indira (1998), who found that the number of members negatively affect the demand for external auditing services. The large number of members does not in itself lead to cooperative audits because of the limited education and understanding of the members on the audit itself.

Cooperative scale had a significant effect on the demand for external auditing services. The results are consistent with those obtained Carey et al., (2000) who identified a correlation between the size and the demand for external

and internal auditing services. Previous literature suggested a number of theoretical explanations. This study is inconsistent with that of Januari and Nasir (2006) who reported that scale does not affect the demand for cooperative audits. The effect of cooperative scale to the demand for external auditing services is very significant because large-scale and developing cooperatives expect increases in the volume of transactions, which may result in errors in accounting data and financial statements and could require cooperative audits to ensure accuracy.

Members had no effect on financial performance because of the lack of members participating in the cooperative effort. The results of this study are inconsistent with those obtained by Djumahir et al. (2001) who found that the number of members influences the cooperative in the sense that the degree of independence of the financial performance of a cooperative is measured in terms of the level of its health or independence.

Total liabilities have a significant effect on the financial performance of cooperatives. A greater amount of liabilities resulted in better performance of these institutions because all work plans can be met generally. The acquisition of debt is already part of the work plan of how funds, which must be added through the debt both in the short term and long term with respect to the level of costs, would be acquired because of the dependent obligations. This study is different from that of Djumahir et al. (2001), who stated that obligations or debts cannot measure the level of performance because performance should be proved by the interest rate to be paid.

The demand for external auditing services has a significant effect on the financial performance of cooperatives, which suggests that the need for financial reports is considered important indecision-making. The general objective of the audit of financial statements is to provide a statement of opinion on whether the financial statements presented are fairly examined in all material aspects and are in accordance with accounting principles. These financial statements indicate the condition of the company as a whole. The audit is also used to show whether the financial statements can be used as a basis for development and planning, particularly in the improvement of working conditions, quality and performance. The management requests for audit to determine the strengths and weaknesses of the company, which will enable them to formulate plans to improve the development of the

company, to learn of the circumstances and abilities of employees on a regular basis as well as to encourage a healthy reciprocity between superiors and subordinates. The results are consistent with that obtained by Prasad (1999) who provided suggestions related to the level of independence of auditors in cooperatives. Indrawati and Donny (2007) found no difference between the financial performance of cooperatives that use public accountant services and that of cooperatives that do not use the services of a public accountant. Bracker and Pearson (1999) also discovered no difference in the performance of managers in companies that use and do not use the services of a financial consultant.

Cooperatives are expected to maintain or further improve their financial performance and to collaborate with auditors by providing the data and information needed examine financial performance accurately. Good cooperation between the cooperative management and auditors will ensure that audit work will be completed in a timely manner.

The services of a public accountant should be used not only to gain members' trust but also to focus on records found by auditors. Appropriate steps should be taken to correct existing errors or problems. In this case, public accountants should be more geared towards inefficiency because the costs due to inefficient operations costs could be quite large, and affect the profits of a cooperative considerably.

The findings showed that the number of members has no effect on financial performance. We recommend members to participate actively in improving the performance of the cooperative, business capital, decision-making and monitoring so as to increase the ability of members to participate in these activities, thereby increasing the need to extend the cooperative activities. Extension activities are intended to improve understanding of the obligations and rights of a person as a member of the cooperative and to provide understanding of means to realising these rights and obligations. Counselling should also be conducted as an information activity to enhance the perception on cooperatives of the society at large.

Cooperative management should improve its performance by increasing human resources to improve the efficiency of managing cooperatives through cooperative education. The goal of cooperative education is to

acquire qualified human resources to support a cooperative normative life and a professionally and managerially strong economic condition. This study can be used as a reference for the development of further studies and is also expected to add to the factors that might affect the demand for external auditing services and financial performance, for example, cost audit, perceptions of quality human resource management and board of supervisors.

REFERENCES

- Arens, Alvin A. and James K. Loebbecke (1996). *Auditing: an integrated Approach*, Edition the Seventh, New Jersey: Prentice-Hall, Inc.
- Bond Accounting Indonesia (2009). *Accounting Standards Financial Entities without Public Accountability*. Jakarta.
- Bracker Jeffrey S. and Jhon N. Pearson (1990). The Impact Of Consultants on Small Firm Strategic Planning, *Doctoral Dissertation*, Georgia University, Atlanta.
- Carey, Peter, Roger Simnett., and George Tanewski (2000). "Voluntary the Demand for Internal and External Auditing by Family Businesses". *Auditing: A Journal of Practice & Theory*. Vol. 19: 37.
- Chow, Chee W. (1982). The Demand for External Auditing: Size, Debt and Ownership Influences, *Accounting Review*.
- Cooperation Department (1988). *With Cooperative towards Economic Democracy*.
- Djumahir, M. S. Idrus and U. Salim (2001). *Analysis of Financial Performance of Cooperatives of Indonesian Officer (KPRI) in Malang*.
- Guy, dan M., C. Wahyne Alderman and Alan J. Winters (2001). *Auditing*. Edition Indonesian. Erlangga. Jakarta.
- Hendar and Kusnadi. (2005). *Economic Cooperation*. Second Edition, Publisher FE Institute, University of Indonesia. Jakarta.

Januarti, Indira and H. M. Nasir (2006). Factors that Affect the Demand for Audit on Cooperatives in Central Java. *Journal MAKSI* Vol.6 no 2 August 2006: 175-186.

Januarti, Indira (1998). *Request Audits on Cooperatives and the Implication for the Profession of Public Accounting ex Resident Semarang*, Thesis of Diponegoro University.

Khalik-Abdel, A. R. (1993). "Why Do Private Companies Demand An Audit? A Case For Organizational Loss of Control". *Journal of Accounting, Auditing and Finance* (Winter) 8:31-52.

Ministry of Cooperatives and UKM, Permen Number : 14/Per/M.KUKM/XII/2009 About *Cooperative Health Assessment Guidelines Save Loan and Save Loan*.

Nasir, Mohammad (1995). Factors That Affect Manufacturing Companies in Central Java to the External Audit Service Requests and The Implications for the Development of the Profession of Public Accounting in Central Java. *Thesis*. Postgraduate Program is Gajah Mada University.

Prasetyo, Tri (1999). *The Influence of Service or Consulting Services Provided by the External Auditor in the Form and Quantity of Advice on The Level of Independence of Cooperative*.

Regulations of the State Minister of Cooperatives and Small and Medium Enterprises of the Republic Indonesia Number: 14/per/m.kukm/xii/2009 on the *Changes to the Rules of State Minister of Cooperatives and Small and Medium Enterprises*.

Ropke, Jochen (1987). *The Economic Theory of Cooperative Enterprises in Developing Countries*. With Special Reference of Indonesia, Marburg: University of Marburg.

Sitio, Arifin and Halomoan Tamba (2001). *Cooperative, Theory and Practice*. Erlangga: Jakarta.

- Sumanto, Agus (2003). An Analysis of the Perceptions of Companies That Do Not Go Public to Demand an Audit in East Java. *Thesis*. Postgraduate Program Magister Master Accounting Science Diponegoro University (not published).
- Susilowati, Dewi (2001). An Analysis of the Perceptions of Companies That Do Not Go Public to Demand for Audit. *Thesis*. Postgraduate Program Magister Science Accounting Diponegoro University (not published).
- Tauringana, Venancio and Steve Clarke (2000). "The Demand for External Auditing: Managerial Share Ownership, Size, Gearing and Liquidity Influences". *Managerial Auditing Journal*. Vol. 15: 160.
- Welter G, Kell William, CC. Boyton, Richard Ziegler (2001). *Modern Auditing*, 7th. Willey International Edition.
- Yuhertiana, Indrawati and Donny Arsilo Sofyan (2007). Analysis of the Financial Performance Differences in a Cooperative Society Independent at Banyuwangi Regency on Public Accountant Office Service. *Journal Research Economy and Business*. Vol. 7:1.