

DEVELOPMENT OF MINIATURIZED CONTROL CIRCUIT OF AUTO RECLOSER EARTH LEAKAGE RELAY FOR A SINGLE PHASE 230V

Zulkifli Bin Mat Yahya

Faculty of Electrical Engineering
Universiti Teknologi MARA Malaysia
40450 Shah Alam, Selangor, Malaysia
e-mail: zulkiflibp89@gmail.com

Abstract— This paper presents development of miniaturized control circuit of auto recloser earth leakage relay for a single phase 230V in consumer unit as the protection devices. The study includes the development of control circuit of earth leakage relay (ELR) that response to the earth fault occurred due to lightning strike or short circuit. This control circuit will reconnect the circuit with utility supply automatically with a specific time that set without any human interface. The Peripheral Interface Controller (PIC) microcontrollers, PIC16F877A are used as the main component or element in the control circuit. The control circuits are used to control the contactor that act as a residual current device (RCD) to cut the power supply from the utility to assembly or electrical appliances when detected earth fault occurred by zero current transformer (ZCT) and sent the electrical signal to earth leakage relay (ELR). The protection devices are using ELR and contactor to replace the function of RDC, so the RCD does no longer use as protection devices. The simulation and development of control circuit are using PROTEUS simulation software.

Keywords-component; reclose; ELR; protection devices;

I. INTRODUCTION

Power distribution networks have been operated in an easy and simple unidirectional way. Many of electrical fault such as short circuit or overcurrent and earth fault that occur are momentary in nature. As an example, earth fault mainly occurred due to lightning. In networks with directly earthed neutral an earth fault is equivalent to a phase-to-earth short circuit. The current magnitude will in this case be almost equal to the fault current of phase-to-phase short circuit. Malaysia is one of the countries that have the high frequency of lightning strike in the world.

Statistics have shown that Malaysia has an average of 204 lightning days a year which is equivalent to 40 strikes per square kilometers per year. Base on reported by the star, March 2011, Malaysia is the second highest lightning strike occurred in the world. Nowadays, the most of the common use protection component in consumer units is RCD and in

distribution board (DB) is ELR. ELR is a safety device that switches off electricity automatically whenever it detects the electric current is unbalanced between the live conductor and the neutral conductor and the breaker will automatically open. It will act to cut the electricity supply off to your house if there were any damages to assembly or electrical appliances such as leakage current to earth through live conductor contact to electrical appliances frame which could expose the consumer to electric shock.

If the wiring at your house is not fitted perfectly or the qualities of electrical appliances are low, there are probabilities of high current leakage to earth. This could cause electric shock as those described above and could also cause the fire if this state is protracted in the environment which sensitive with heat. ELRs are far more sensitive than normal fuse and circuit-breakers and its providing additional protection against electric shock. Because of that the breaker has to be reset manually to back to normal operation. The several previous researches have been conducted on power protection. Among the works that be highlighted are the work conducted by Massimo Mitolo in 2007 which is he did Shock Hazard in the Presence of Protective Residual Current Devices.

This work is about to clarify these particular fault conditions, occurring in the presence of healthy Residual Current Operated Circuit-Breakers (RCCBs). One of the fault conditions is direct contact with part at different potentials. The direct contact with parts at different potentials cause a minimal leakage current-to-ground, as the conductors offer a lower impedance path to the current, while the RCCB will sense this reduced component current and the current will trigger the RCCB in a timely fashion to prevent injuries. The permissible residual current threshold requires by Electrical installation of building [1].

Residual Current Operated Circuit-Breakers (RCCBs) operates by detecting the Zero-Sequence current, which is the vectorial summation of the three-phase currents on a three-phase circuit [2]. The function of ELR is same function as RCCB or now is known as RCD which is to trip if the vectorial current is not equal to zero. The others previous researches have been conducted on power protection is the work conducted by Li Chunlan, Du Songhuai , and Liao Congyan in 2008 which is they did Impacts of Distribution Network Unbalanced Impedance on Action Performances of Residual Current Operated Device. This work is to demonstrate the influence of unbalanced impedance on the action performance of ELR [3]. Auto recloser is a protection devices equipped with a mechanism that can automatically close the breaker after it has been opened due to earth fault. Automatic circuit reclosing is extensively applied to overhead line circuits where a high percentage of faults that occur are transient in nature.

Automatic reclosing is widely adopted in medium voltage networks. Automatic reclosing is easy to implement in a radial distribution network. It becomes problematic when distributed generation is introduced to the network [4]. Auto recloses functions on the principle of Coordination of Inverse Time Overcurrent Relays with Fuses. The duty of protection equipment is to allow overload currents that occur during operation, yet to prevent impermissible loading of lines and equipment [5].

To avoid damages in the case of short-circuits the relevant equipment must be tripped in the shortest possible time [6]. Simulation software used to model the auto recloser earth leakage relay control circuit is PROTEUS simulation software. Software models which is in the form of coding representing the operation of the circuit. One of the most important considerations must take into design protection system is reliability. Reliability can be divided into two aspects which are dependability and security [7].

Dependability is defined as the degree of certainty that a relay system will operate correctly when there is a fault on the system. For security, it more relates to the degree of certainty that a relay or relay system will not operate incorrectly when there is no fault on the system [8]. According to different protection levels for the lightning protection system, reference [9] mentions lightning current parameters of 100-200 kA 10/350 μ s for a first lightning stroke which corresponds to a positive strike which is the most severe case in order to protect the system. An automatic reset circuit of earth relay in consumer unit has been done by past year UiTM student that use AC timer and relay as a main control circuit.

Therefore this project is aim to design and develop a miniaturized control circuit model of auto recloser earth leakage relay for a single phase 230V that can reconnect the system with the utility supply automatically without any human interference. The concept is if there are earth fault occurred, the ELR will trip and will reclose automatically after seven seconds. But if the fault is still existing the ELR will trip back for a second time and try reconnect again after 15second

and if the fault still existing, the breaker will be permanently trip until the breaker are manually reset.

This project will concentrate on low voltage usage of residential single phase 230V which is the common voltage rating of power supply systems that used from the utility in Malaysia and use the PIC microcontroller as a main control element. So, consumer does no longer have to switch on the protection devices manually after lightning strike occurs.

II. CONTROL CIRCUIT OF AUTO RECLOSE SYSTEM

This paper presents the development of miniaturized control circuit of auto recloser earth leakage relay for a single phase 230V for residential consumer unit of protection devices. The design of auto recloser earth leakage relay is to protect the system from the fault that cause by the earth fault due to the lightning or over current that will be hazard. The control circuit design consist of microprocessor, earth leakage relay, miniature circuit breaker, AC contactor, zero current transformer and solid state relay. The figure below show the description of automatics control circuit for protection devices in consumer unit.

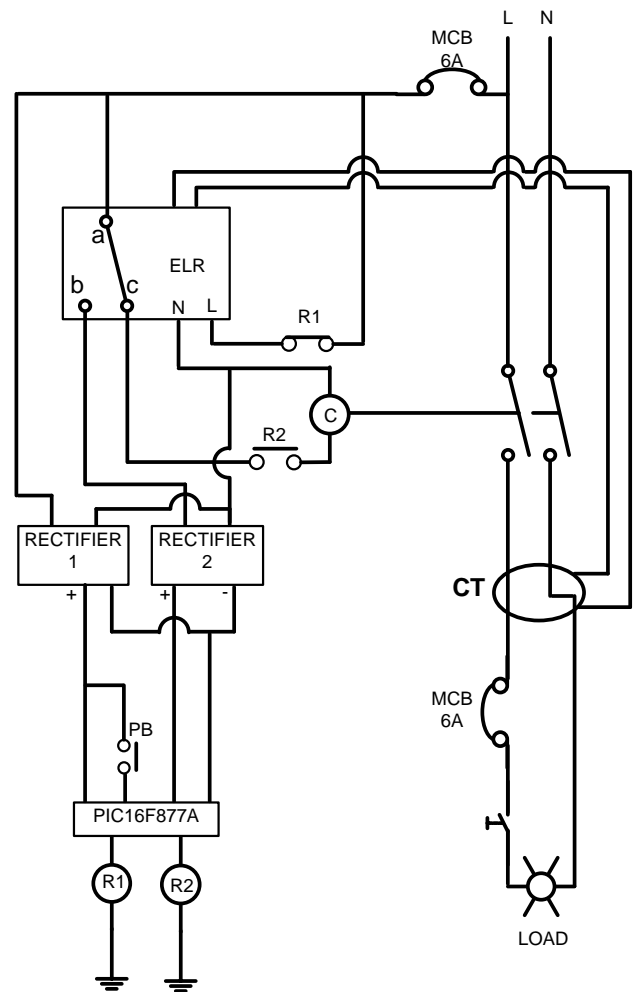

Figure 1: Automatic Control System

A. *Microprocessor PIC16F877A*

Peripheral Interface Controller (PIC) is one of the popular devices for programming control system either in education program, industries developer or as a hobby due to lower cost, large user base and wide availability. PIC16f877A is one of the family members of PIC with 200 nanosecond instruction execution that easy to program using CMOS FLASH because of flash program memory type with architecture of a 40 pins package and has 33pins that can be used for input or output, 2pin for voltage supply and 2 pin for grounded system. The feature of PIC16F877A are 14kB of program memory, 5MIPS of CPU speed, 368 bytes of RAM, 256 bytes of EEPROM data memory, 8 channels of 10 bit analog to digital converter (ADC), 2 comparator, 2 capture/compare/PWM function, 2 comparator, 2 8-bit and one 16-bit timer, digital communication, operating voltage range of 2 to 5.5 volt and can be operate in the temperature range of -40 to 125 degree Celsius (C). Base on the entire feature make it ideal for use in application in industrial, appliance, automotive and education.

B. *Earth Leakage Relay(ELR)*

Earth leakage relay is one of the protection devices that ensure the protection of electrical installation and person against direct and indirect contact, it's also provides detect and monitoring of earth fault current flowing in a power system. ELR Provides real time leakage current display and leakage fault current recording. The methods of ELR function is Current measurement based on fundamental frequency and prevent nuisance tripping. The advantage of ELR is has a Digital display for ease of use and Robust casing protects the unit from external interference. It does also can be used in Industrial equipment protection and suitable for low voltage distribution protection. The ELR has 3 type of toroid's that are circular toroid, rectangular toroid and open toroid.

C. *AC Contactor*

AC contactor is an electricity control switch like a relay but it use for switching AC power circuit with high current rating and controlled by a circuit has low power level than switched circuit. An AC contactor has 3 main components that are power supply contact, auxiliary contact and contact spring. The contacts will active when have electromagnetic forces that will drive to close the contact. An AC contactor is design to be directly connected to the high current load devices that normally switching current more than 15 ampere.

The contactor will active when current past through the electromagnet and that will produce the magnetic field that can attract the moving core of the contactor. The force produced by the electromagnet will hold the moving and fixed contact together. Contact spring will return the moving contact to the initial position when don't have any magnetic field. The AC contactor will get either for single phase or three phase application.

D. *Solid State Relay (SSR)*

The action of an SSR same with the mechanical relay that as a switches. The SSR used the thyristor as a main

component to allow and cut the current flow through it. The thyristor are used because of it able to operate on high power application and at rated frequency. An SSR have 5 pin of connection that is 3 for input and 2 for output. The pin port at the input side is a voltage sources, ground and signal port. It can turn on up to 250v ac when receive 5v dc at signal port/pin. PIC micro controller has an input/output pin are 5v, so this allow a program to turn on and off a devices through SSR. The advantage of using an SSR than the mechanical relay is no moving part during switching thus prevent from the losses and the response time for the switching is more faster.

E. *Zero Current Transformer(ZCT)*

The ZCT protection is response to the residual current. It has two output contact system that connect to the port on earth leakage relay. ZCT surrounds the live conductor, therefore it excited by the magnetic field corresponding to the algebraic sum of the current flowing in the live and neutral conductor. The current induced in the toroid and the electrical signals at the terminals of the winding are therefore proportional to the residual current. If some current leaking instead of returning through the neutral conductor, it will sent the electrical signal to the ELR.

F. *Miniature Circuit Breaker (MCB)*

Miniature circuit breaker are desing to protect an electrical equipment from damage causes by the short circuit or over load. Its widely use in residential and also industries installation. The component of MCB consist of bimetallic strip,current coil, moving contact and fixed contact. The MCB will trip when the bimetal strip became over heated causes by the over load and cause the displacement of latch point. Its can cause the spring preasure release and make the moving contact move away from the fixed contact. Same goest when short circuit occure, the mmf of the coil cause the latch point displacement and make spring preasure release also moving contact move away from fixed contact.

Operation of the circuit:

During the normal condition of operation, the zero current transformers does not sent any electrical signal to the ELR because of no residual current occur on live and neutral conductor. But when earth fault occurs due to lightning strike or short circuit, the ZCT will detect the different magnitude of current flowing through the live and neutral conductor and it will sent the electrical signal to the ELR. When the ELR get the electrical signal from ZCT it will trip and the point of ELR now changing from point c to b. The control circuit already has a power supply direct from the utility supply through the rectifier 1 and in standby condition. When the point of ELR change from c to b, it make the rectifier 2 active and change the AC signal to DC signal hence give the active signal to the microcontroller PIC16F877A. For initial condition, the RB5 output from the PIC is active (1) and make the solid state relay 1 (R1) in close position and output of RB4 is 0 and make the solid state relay 2 (R2) in open position.

During the PIC16F877A get the signal from rectifier 2, it can start to run the operation as programmed on it, R1 will change to open circuit and the current can't flow through it. This condition causes the ELR don't have the supply from the utility for a 10 second and the relay R1 change back to initial condition. It causes the current flow through it and the ELR get back the supply from the utility. When the ELR get the supply back from the utility, the point of ELR now change from the b position to c and at the same time the PIC16F877A will give the signal to R2 to active (1) condition for a 10s second and the current flow through it will make the close circuit. When the contactor gets the supply that causes by the R2 in active condition, it will energize the coil and reconnect the supply from the utility to the load. After 10s second, R2 will back to the initial condition. The electrical equipment gets the supply from the utility and can operate as normal condition. This process only will occur for two times only to ensure that it not damage the electrical appliance that causes by the permanent fault. The consumers need to manually reset the system when the system permanently trip.

III. METHODOLOGY

As shown in figure 2 below, this research is to design and develop a model of miniaturized control circuit of auto recloser earth leakage relay for a single phase 230V that will reclose the circuit breaker automatically to the utility supply after the earth fault occurs for a several time before the circuit breaker trip permanently until the control circuit manually reset. The detail flow work below of all process plans in order to make sure that control circuit will fully function.

This control circuit can operate to control single phase 230V electricity supply by the utility. The simulations of the control circuit are design using PROTEUS simulink software in order to get the desire output and the actual output will be fine using the implementation of hardware and also for test the functioning and reliability of control circuit.

To design the control circuit, some important step must be follow as shown in figure 2 below to make sure the designing proses will be done smoothly as follows:

- i. Study about the protection devices (RCD and ELR)
- ii. Study on PROTEUS simulink software
- iii. Design the control circuit
- iv. Study on mikroC pro for PIC software
- v. Create the coding for control circuit
- vi. Simulate the control circuit using PROTEUS
- vii. Check the functionality of the control circuit and improve
- viii. Design the PCB
- ix. Build the hardware and check the actual result
- x. Troubleshoot

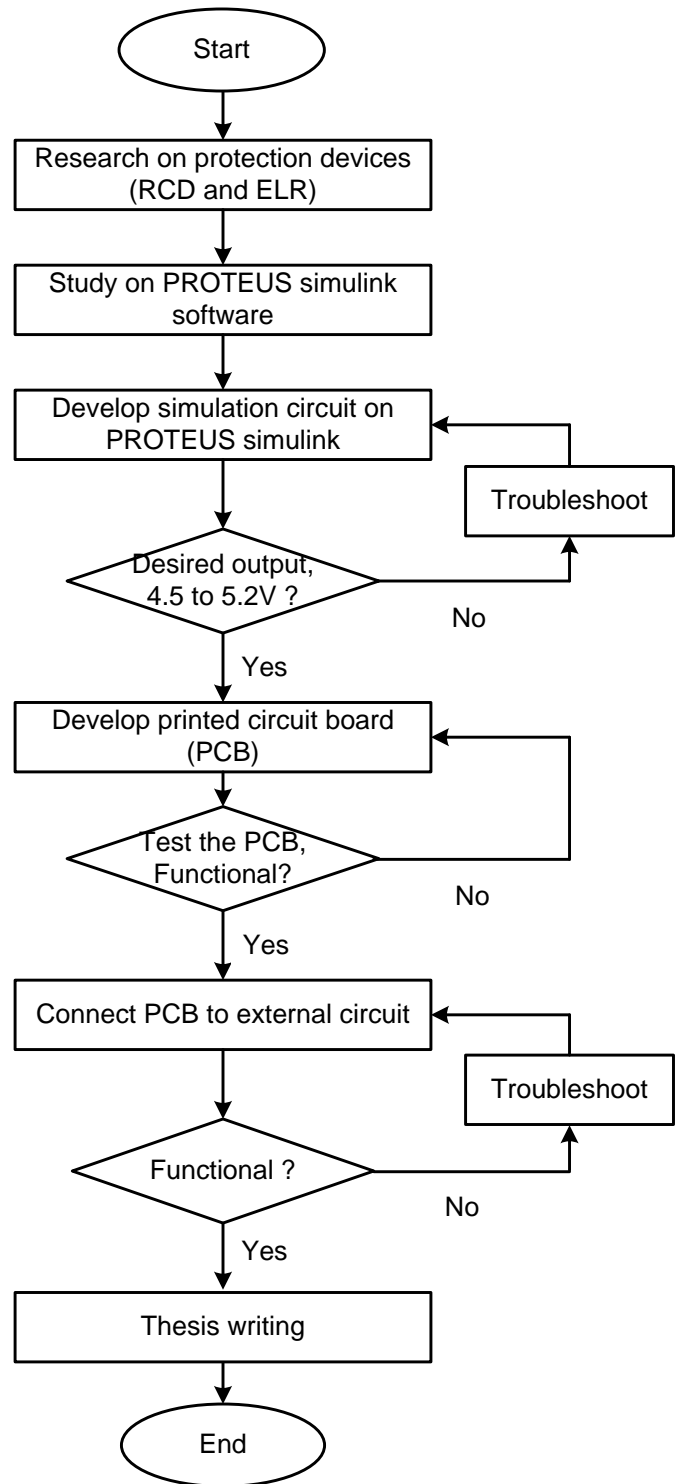

Figure 2: Flow Chart of Methodology

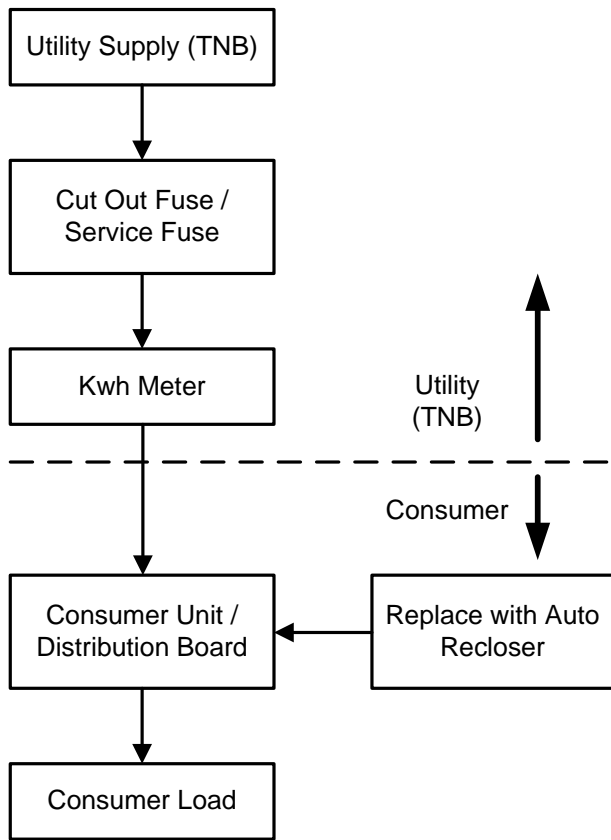

Figure 3: Control Circuit System

Base on the Figure 3 above, the auto reclose circuit will replace the distribution board (DB) such as RCD to protect the consumer household electrical equipment such as home appliances and industrial electrical operated equipment when earth fault occurs. The auto recloser is installing between the consumer load and the Kwh meter from the utility supply as figure 3 above.

IV. CIRCUIT DESIGN

Figure 4 above show the simulation control circuit for miniaturized control circuit of auto reclosed earth leakage relay for a single phase 230V. The simulation control circuit above consist of 2 rectifier circuit as a main supply power to PIC16F877A and as a switches for a earth fault , PIC 16F877A as a main component of control circuit and solid state relay (SSR) to cut and connect the supply to the load. Figure 5 above is the control circuit for hardware model. It consist of PIC16F877A as a main component of control circuit and two rectifier for a supply power to the PIC16F877A and switches during earth fault occur to give the electrical signal to the input of PIC16F877A.

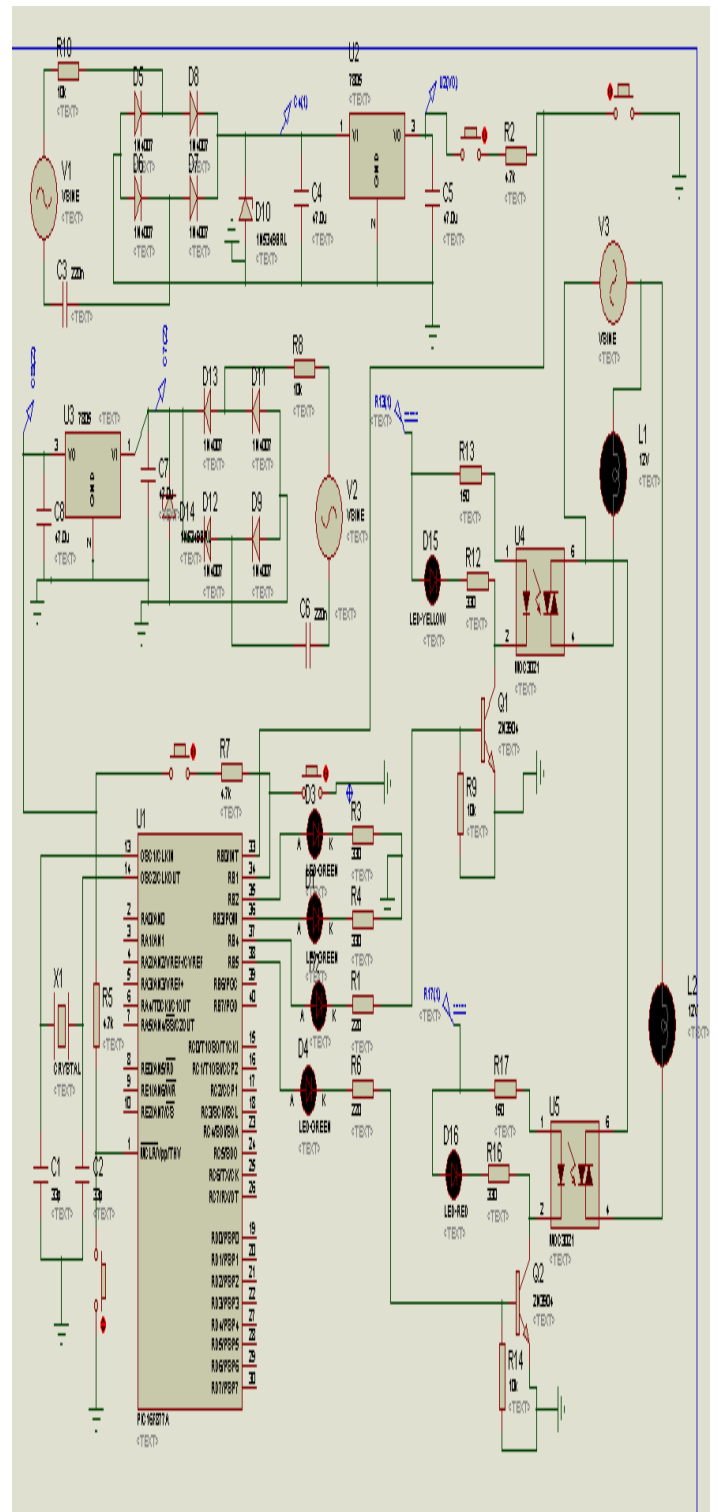

Figure 4: control circuit of simulation

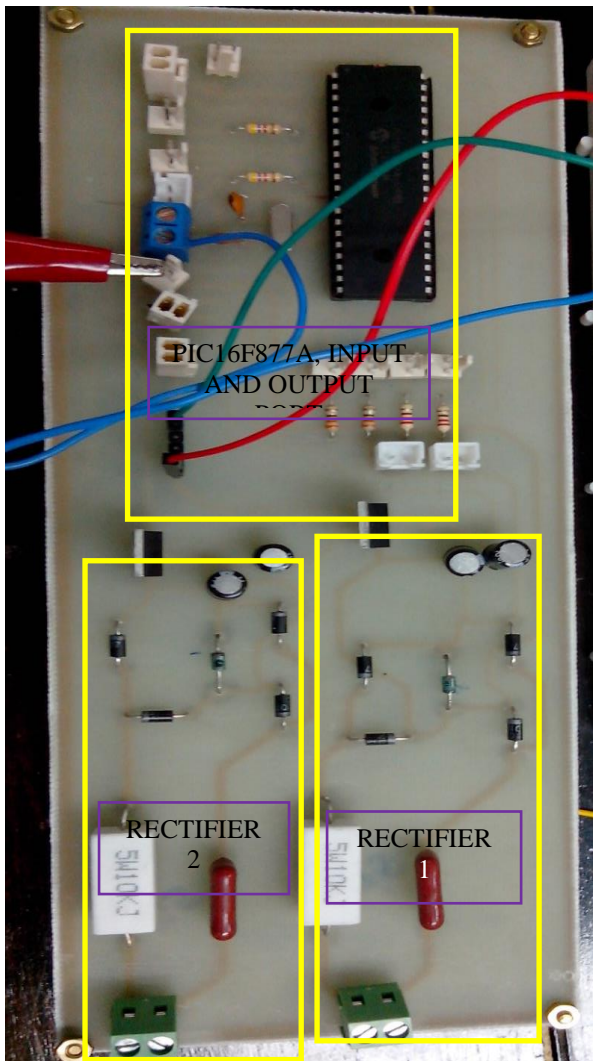

Figure 5: control circuit of hardware implementation

V. RESULT AND DISCUSSION

The design of this project actually planned to implement with the residual current devices (RCD) but when the studies on protection devices are doing, there are some reason that causes the project cannot be continue further using the RCD. During the studies about the protection devices, there are found that the RCD just can be reset by the mechanical movement of the main toggle switch and don't have any point that can be use connect as the supply sources to the control circuit when the tripping occurs and found that the earth leakage relay (ELR) can be used to replace the function of RCD as a protection devices.

From the simulation that has be done using PROTEUS simulation, the output from the PIC16F877A that indicate by the 4 LED fulfill the desire output that need to control the external circuit. The 4 LED from the output represent the first

time of tripping (LED 1), second time of tripping (LED 2), input signal for the solid state relay (SSR)1(LED 3) and SSR2 (LED 4). Since the ELR component does not exist in PROTEUS simulation software, the input during the lightning strike occurs is representing by the push button (PB).

When the PB is press for a first time, LED 1 will turn on followed by the LED 3. After a seven second, LED 3 will turn off and LED 4 will turn on for a 10 second. When the LED 4 turn off, LED 1 also will follow the LED 4 to turn off, the turns off of the LED 1 shown that the first cycle of the recloser circuit are done.

When the PB button is press for a second time, LED 2 will turn on followed by the LED 3. After a 15 second, LED 3 will turn off and LED 4 will turn on for a 10 second. When the LED 4 turn off, LED 2 also will follow the LED 4 to turn off, the turn off of the LED 2 shown that the second cycle of the recloser circuit are done. If the PB are press again, the PIC16F877A will not give any reaction (function) to the output until the circuit are manually reset for the safety reasons in case the consumer equipment have a permanent fault.

The output from the LED 3 is for the input signal for the SSR1 where the SSR 1 is normally close that used to cut and connect the supply from the utility to the ELR. While the output from the LED 4 is for the input signal for the SSR 2 where the SSR 2 is normally open that used to give the supply to the contactor to reconnect the utility supply to the consumer load.

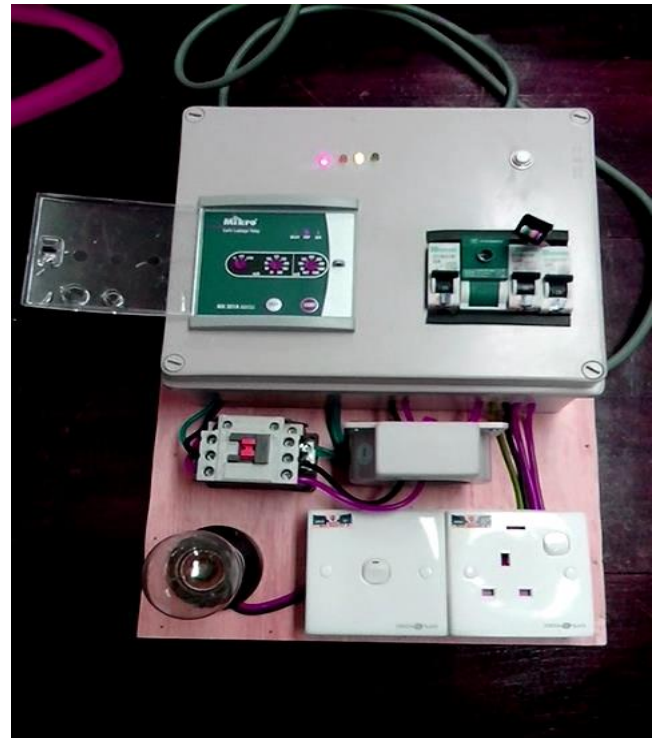

Figure 6: Hardware model during tripping

Figure 6 above show the hardware model of miniaturized control circuit of auto recloser earth leakage relay during tripping time. The control circuit will trip when the zero current transformer detect the earth fault.



Figure 7: Hardware model during reconnect the utility supply

Figure 7 above show the hardware model reconnect the circuit to utility supply properly after tripping is done. The supply is connected after the contactor gets the auxiliary supply from the control circuit. The control circuits are function due to the control circuit will reconnect to utility supply when the tripping occurs. However the control circuits not properly operate as a design where the control circuits are design to reclose when tripping just for two times but the control circuit will reclose each time the tripping occurred. Base on the design, the control circuit will not reclose the circuit when the system tripping exceed more than two times.

VI. CONCLUSION

This paper has presented development of miniaturized control circuit of auto recloser earth leakage relay for a single phase 230V. In this work, the PROTEUS simulation software is used to investigate whether the circuit can work to achieve the objective. From the results that get from the simulation and hardware model, it's proven that the control circuits are functional to reclose the circuit to consumer unit from utility supply automatically without any human interfaces. However the control circuits not properly operate as a design where the control circuits are design to reclose when tripping just for two

times but the control circuit will reclose each time the tripping occurred. The failure of the control circuit not fully function is suspected by the coding of PIC16F877A due to the control circuit is looping just on 1st loop and not moved to the other loop. Some of the objective of this project was achieved which indicates workable control circuit to reconnect the supply to consumer unit automatically without any human interfaces. The total cost that used for this final year project is around RM750.00. This project will be continuing to achieve the objectives even though has been present with the panel of final year project.

VII. FUTURE OF WORK

In order to achieve better result and future work of auto recloser system to judge the performance and to improve the reliability, it is suggested that the Remote control will be used to reset the control system or online control by the computer, use LCD display to display the date, time and magnitude of the lightning strike and also short message service (SMS) alert to the owner to inform the owner that their home stuck by the lightning strike.

ACKNOWLEDGMENT

In this regard, I would like express my gratitude and thanks to my family, all my friends for their help and support and to all people who have been involved directly or indirectly contributes towards the progress of this project. I also would like to express my sincerely gratitude and thanks to my project supervisor, Hj. Ir. Harizan Bin Che Mat Haris and my co-project supervisor, Pn. Wan Noraishah Binti Wan Abdul Munim for their constant advice, suggestion, kindness, support, and guidance during the progression of this project and helped me to start quickly with project during the early years. Without guidance and support from them, this project will not succeed.

REFERENCES

- [1] M. Mitolo, "Shock Hazard in the Presence of Protective Residual Current Devices," in *Industrial & Commercial Power Systems Technical Conference, 2007. ICPS 2007. IEEE/IAS, 2007*, pp. 1-6.
- [2] IEEE Standard 100 "The Authoritative Dictionary of IEEE standard terms", 2004, 7th Edition
- [3] C. Li, et al., "Impacts of distribution network unbalanced impedance on action performances of Residual Current Operated Device," in *Electric Utility Deregulation and Restructuring and Power Technologies, 2008. DRPT 2008. Third International Conference on, 2008*, pp. 2105-2110.
- [4] M.Njozela, Non-Member, S.Chowdhury, Member, IEEE, and S.P.Chowdhury, Member, IEEE. , "Impacts of DG on the Operation of Auto-Reclosing Devices in a Power Networkl, Power and Energy Society General Meeting IEEE, 24-29 July 2011.
- [5] Indrapal, Shubhra chaturvedi – —Autorecloser and Sectionalizerl, *HANDBOOK OF SWITCHGEARS*, Downloaded from Digital Engineering Library @ McGraw-Hill (www.digitalengineeringlibrary.com) Copyright © 2007 The McGraw-Hill Companies.

- [6] Sukumar M. Brahma, Student Member, IEEE, and Adly A. Girgis, Fellow, IEEE., —Development of Adaptive Protection Scheme for Distribution Systems With High Penetration of Distributed Generation, IEEE TRANSACTIONS ON POWER DELIVERY, VOL. 19, NO. 1, January-2004.
- [7] Hassan Khorashadi-Zadeh, and Zuyi Li, Member, IEEE, Vahid Madani, Senior Member, IEEE, " Adaptive Dependable and Secure Protection Systems for Electric Power Systems", 2008.
- [8] X. Luo and M. Kezunovic, "A Novel Digital Relay Model Based on SIMULINK and Its Validation Based on Expert System," in Transmission and Distribution Conference and Exhibition: Asia and Pacific, 2005 IEEE/PES, 2005, pp. 1-6
- [9] IEC DIS 81 (CO) 14/07.91.(2004) Protection of structures Against Lightning. Part 1: General Principles Section 1: Guide A Selection of Protection Levels for Lightning Protection Systems
- [10] IEEE Standard for Low-Voltage AC Power Circuit Breakers Used in Enclosures - Redline. IEEE Std C37.13-2008 (Revision of IEEE Std C37.13-1990) - Redline: 1-29.
- [11] Brahma, S. M. And A. A. Girgis (2004). "Development of adaptive protection scheme for distribution systems with high penetration of distributed generation." Power Delivery, IEEE Transactions on 19(1): 56-63.
- [12] Dalke, G. And J. Horak (2005). "Application of numeric protective relay circuit breaker duty monitoring." Industry Applications, IEEE Transactions on 41(4): 1118-1124.
- [13] Xiaowen, Z. and Z. Hudong (2011). The accelerated life experiment study of Solid State Relay. Quality, Reliability, Risk, Maintenance, and Safety Engineering (ICQR2MSE), 2011 International Conference on.
- [14] Yanxin, L., W. Qiwu, et al. (2011). Study of EMP effects experiment on the solid state relay. Mechanic Automation and Control Engineering (MACE), 2011 Second International Conference on.
- [15] "IEEE Guide for Automatic Reclosing of Line Circuit Breakers for Ac Distribution and Transmission Lines (2003)." IEEE Std C37.104-2002: 0_1