

Implementation Of A Single Phase AC Adaptor Using PIC16F877 Microcontroller

Hasaniah Binti Yahya
Faculty of Electrical Engineering
Universiti Teknologi MARA Malaysia,
40450 Shah Alam, Malaysia
Email: muthiah858@yahoo.com

Abstract – This paper presents the design and implementation of a single phase inverter that produce a 230 V, 50 Hz adaptor. The single phase inverter supplied from a 12 V dc car battery will be fabricated employing a multiple PWM controlled using a microcontroller. The microcontroller of Microchip PIC16F877 is programmed for the implementation of the inverter.

Keywords – Single Phase Inverter, Multiple Pulse Width Modulation (PWM), Microcontroller, PIC16F877, Pic Simulator.

I. INTRODUCTION

The standard AC output waveform supplied by Tenaga Nasional Berhad (TNB) in Malaysia for a single phase supply is 240 ± 10 V ac, 50 HZ frequency. Based on this standard, most of electronic equipment such as laptop (Toshiba) has a 100 to 240 V ac and 50 Hz to 60 Hz input voltage. During travelling in a car, the electronic equipment may need this standard voltage source. Thus a DC to AC adaptor with a 12 V dc input for the car battery may provide such a source. This requires a single phase inverter to be employed. Pulse width modulation is can be used to digitize the power so that a sequence of voltage pulses can be generated by the on and off of the power switches.

A. Single Phase Inverter

Single-phase DC to AC inverter are widely used in industrial applications such as induction heating, standby power supplies and uninterruptible supplies [6]. A block diagram representation a single-phase inverter is given in Figure 1.1.

The inverter consists of four switching devices (i.e. MOSFET) connected in the form of a bridge. The control scheme is implemented using PIC16F877 controller. The circuit will operate when S1 and S4 ON simultaneously, at that time the input voltage, 12 V appears across the load. If S3 and S2 are turned ON at the same time, the voltage across load will be reversed and its -12V.

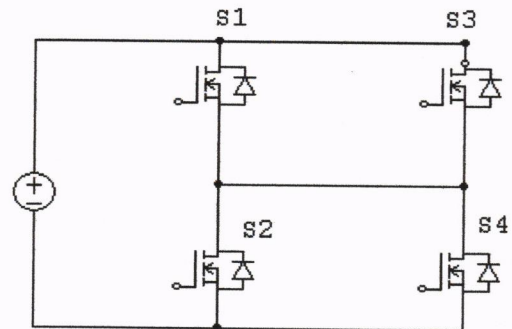

Figure 1.1 Single Phase Inverter

B. Pulse Width Modulation Technique

Pulse width modulation commonly used in industrial application to control the output voltage of inverter to obtain an AC voltage with less harmonic distortion. PWM has a few advantages such as harmonic that was created in low order can be filtered by load inductance and low pass filter. However, there are some disadvantages such as more complex control circuit and increase losses due to frequency switching.

By using multiple PWM the harmonic content can be reduced using several pulses in each half-cycle of output voltage[2]. The generation of gating signal (in figure 1.2(b)) for turning on and off of transistors is shown in figure 1.2 (a) by comparing a reference signal with a triangular carrier wave. Multiple PWM also known as uniform PWM (UPWM)

The frequency of reference signal set the output f_o , and the carrier frequency f_c , determines the number of pulses per half cycle p . The modulation index controls the output voltage[2]. The number of pulses per half cycle is found from equation (1) below,

$$p = \frac{f_c}{2f_o} = \frac{m_f}{2} \quad (1)$$

Where $m_f = f_c/f_o$ is defined as the frequency modulation ratio. The output voltage for single phase inverter is shown in figure 1.2 (c).

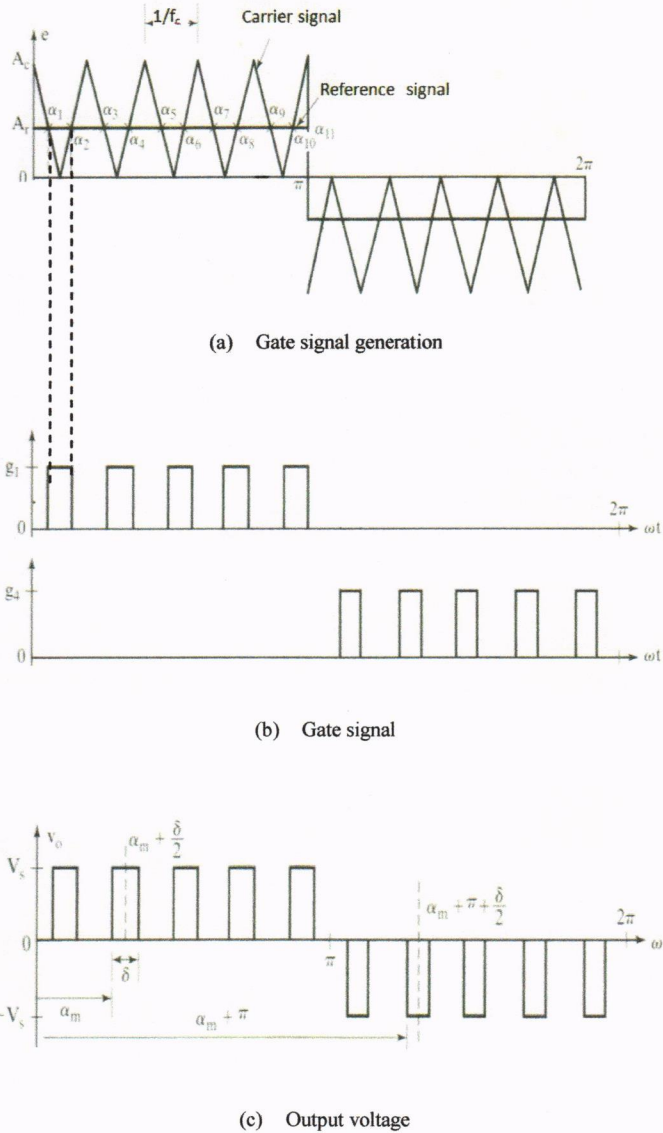

Figure 1.2: Multiple PWM signals [2]

II. SCOPE OF WORK

This project is initialized by a study on the single phase inverter that produce a 230V ac and 50Hz frequency. The next stage is to design a low cost power inverter and how to program microcontroller for generating the PWM signal. To obtain the proper analysis, the suitable switch (MOSFET IRF740) with a switching strategy (UPWM) is applied. After that the model could be developed and simulated using Real PIC simulator for testing PWM and PSIM for circuit simulation.

III. METHODOLOGY

There are two main circuit, a power circuit and a control circuit. The power circuit consists of a single phase inverter, LC filter, and transformer. On the other hand, the control circuit consists of the PIC (Programmable Interface Circuit/PWM program) and gate drivers. The project used many electronic components such as; MOSFETs, Capacitors, PIC and Gate Drivers, to construct the full circuit. Figure 3.1 shows the block diagram of the project. In order to achieve this, a full understanding of the characteristics and theory of each section had to be achieved.

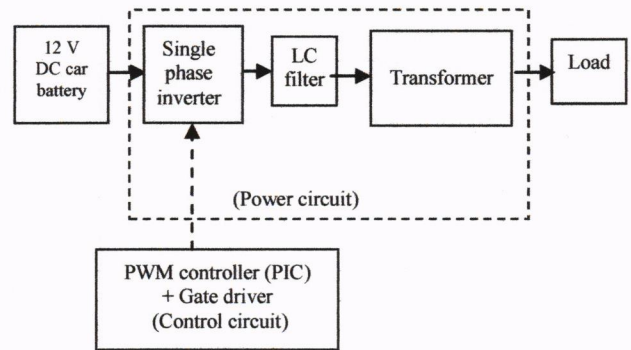

Figure 3.1: System block diagram

A. Control Circuit

1) Microcontroller (PIC16F877)

PIC16F877 is a low power, high performance CMOS 8-bit microcontroller with power saving sleep mode. Figure 3.2 present the PIC16F877 pins assignment for the PWM signal of single phase inverter system. The PWM signal was generated on PIC16F877 programmed by Microcode Studio Plus.

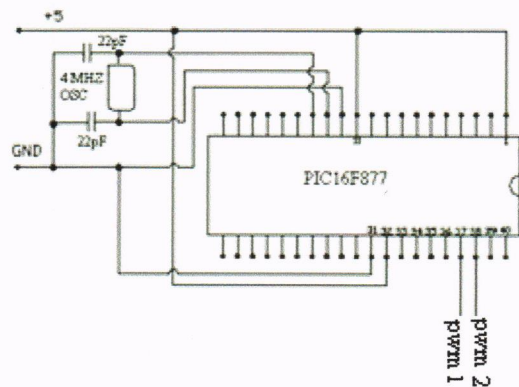

Figure 3.2: Pins assignment for the PWM signal of single phase inverter.

The microcontroller is developed as the controller circuit to make the design simpler, more reliable and the most important is to reduce their dimensions and components in order to reduce cost of development. Only one component can perform the function of a whole circuit, being dependent on the project to be implemented by a small microcontroller embedded in the inverter system. Figure 3.3 below shows the switching strategy and Figure 3.4 shows the MOSFETs firing sequences that are used in this project.

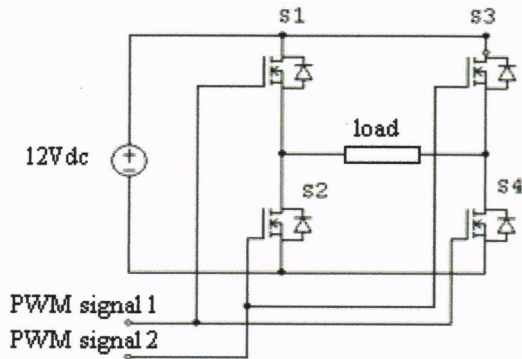

Figure 3.3: Switching strategy for single phase inverter

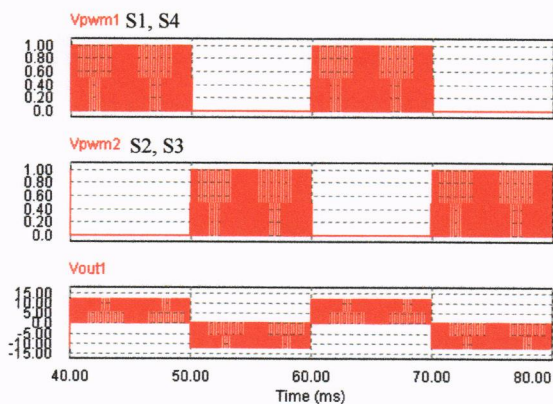

Figure 3.4 MOSFETs firing sequences

The turn ON and OFF switches, S1 and S4 are controlled by PWM 1 generated at pin 37 (RB4). While the PWM 2 at pin 38 (RB5) are controlled S2 and S3. Both PWMs used the control signal that generate by microcontroller either duty cycles, frequencies or voltage. The different is only PWM 2 signal is lagging PWM 1 by 180 degree.

2) Gate driver

An IR2181 Mosfet gate driver chips play as a vital role in creating drive pulses suitable for operation of a full bridge inverter circuit. The IR2181's amplify the 5 V logic signals (PWM) output by the microcontroller to obtain a 12 volt signal necessary to fully turn on the MOSFET of the full bridge inverter circuit. The other function of IR2181 is to provide electrical isolation between the upper control

pulses and the upper MOSFETs of the inverter circuit. Without proper electrical isolation the upper MOSFETs would have a gate-to-source voltage not stable and floating because they are not directly referenced to ground potential. The IR2181 gate driver chips provide electrical isolation by inserting a capacitor and diode, also known as a "bootstrap supply", are shown in Figure 3.6.

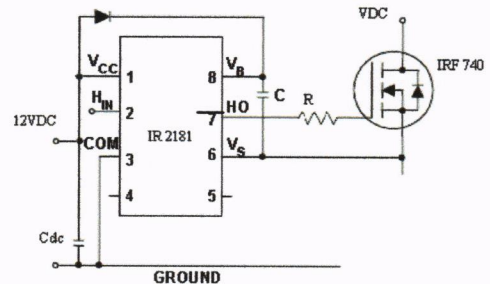

Figure 3.5: Gate driver circuit

This bootstrap method is simple and inexpensive but has some limitations. The duty cycle and the on time are limited by the requirement to refresh the charge in the bootstrap capacitor Cbs. The bootstrap diode (Dbs) should be able to block the full power rail voltage, which is seen when the high side mosfet is switched on. The bootstrap diode should also be a fast recovery diode to minimize the amount of charge fed back from the bootstrap capacitor into the Vcc supply.

B. Power Circuit

The power circuit topology chosen is full bridge inverter. Figure 3.6 shows the full bridge inverter topology. The full bridge topology is chosen with considerations that it must be capable of delivering high current at low voltage. This property is important because the inverter is designed for usage in the car to supply voltage and current in the laptop charging.

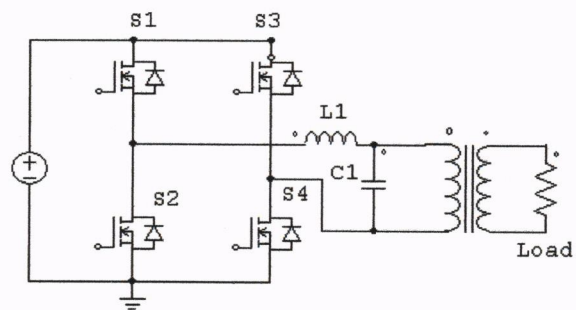

Figure 3.6: Full bridge inverter with LC filter

1) LC Filter and Step-up Transformer

The LC filter is needed to reduce harmonic content and to make the signal become sinusoidal. The sinusoidal output signals then fed to step-up transformer to amplify the voltage to proper level. The arrangement of the LC filter is shown in Figure 3.8

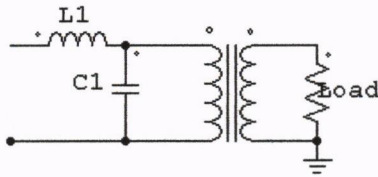

Figure 3.7: The LC filter circuit arrangement

C. Software Design

Microcode Studio Plus was used to create a program that control a PWM scheme. Figure 3.5 illustrates the software flow diagram for PIC16F877.

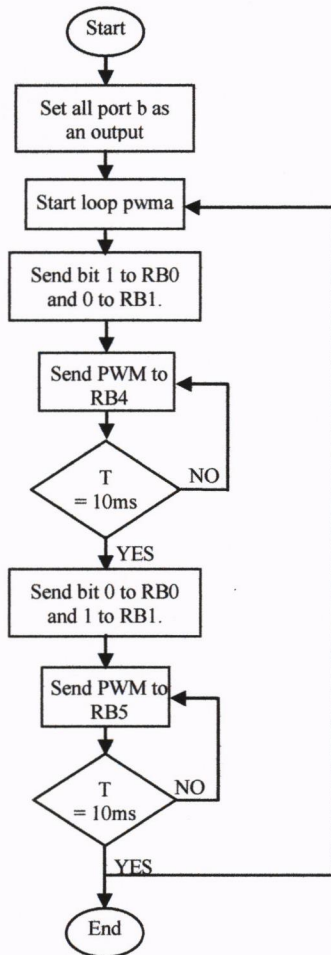

Figure 3.8: Software flow diagram for full-bridge inverter microcontroller

IV. RESULTS AND DISCUSSIONS

A. Software Simulation result

The simulation result from microcontroller output port is shown in Figure 4.1. PWM 1 is output from pin 37 (RB0) and PWM 2 is output from pin 38 (RB1) microcontrollers. PWM 1 is leading PWM 2 by half cycle of the switching signal. Figure 4.2 shows the output voltage waveform from the single phase inverter before filter with resistive load. While the figure 4.3 show the output with filter and after step up by the transformer.

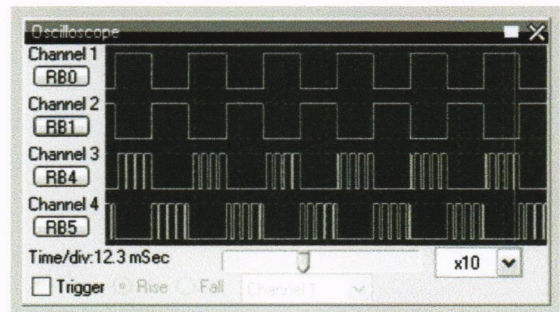

Figure 4.1: PWM signal (12ms/div)

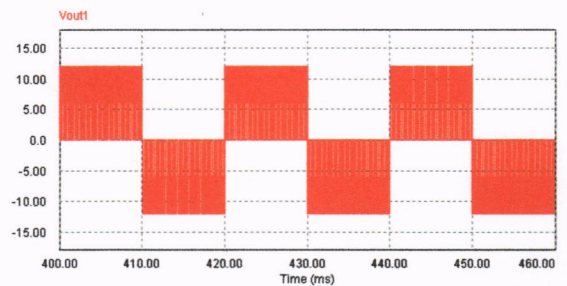

Figure 4.2: Output waveform from single phase inverter before filter with resistive load

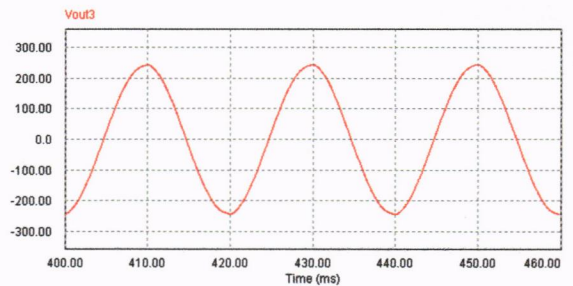

Figure 4.3: Output waveform from single phase inverter filtered and step up by transformer.

B. Experimental results

Tektronix TDS 2024B, four channel digital storage oscilloscope was used to measure the experimental results. Figure 4.4 below show the PWM 1 and PWM 2 waveform (5V/div, 10ms/div) generating pulses from microcontroller. Figure 4.5 shows the output voltage waveform from the

single phase inverter before filter with resistive load. While the figure 4.6 show the output with filter and after step up by the transformer. The output voltage is around 120V and THD is 4.6%.

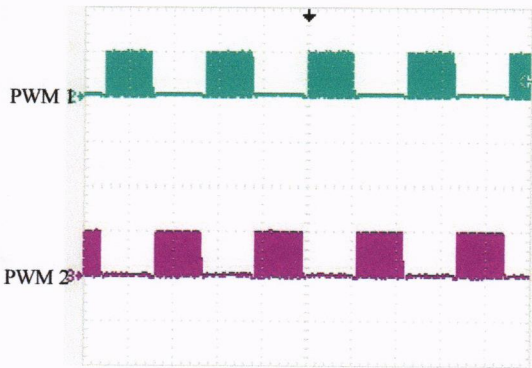

Figure 4.4: PWM 1 and PWM 2 waveform (5V/div, 10ms/div) generating pulses from microcontroller.

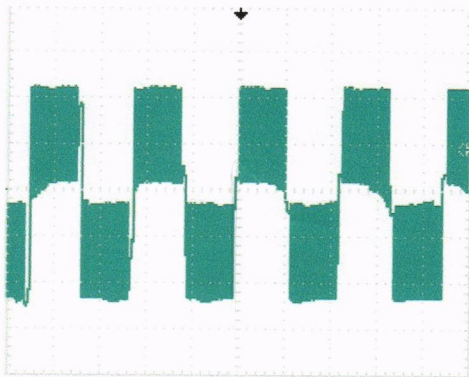

Figure 4.5: Output waveform from single phase inverter before filter with resistive load (5V/div).

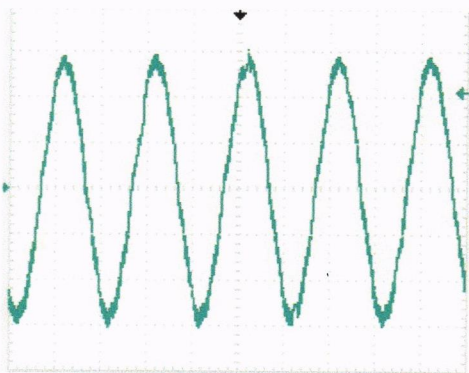

Figure 4.6: Output waveform from single phase inverter filtered and step up by transformer (40V/div).

The experimental result matched with simulation results but the value not exactly same. There are exist some distortion and error in handling the laboratory equipment and component.

V. CONCLUSION

From this paper, the behavior of the DC to AC single phase full bridge inverter have been studied. The project design a low cost car power adaptor producing 230V, 50Hz from 12 V DC car battery employing PIC16F877 microcontroller to produce PWM control pulses. In order to achieve all objectives of this project, simulation and several experiment was made. The simulation was successful done on PSIM to provide proper circuit values for the hardware implementation. However, experimental results only able to achieve ac output of 42 Vrms, 50 Hz. As the conclusion, the objective to implement the ac adaptor is almost achieved. The behaviors of output using resistive load being observed.

RECOMMENDATIONS

The single phase ac adaptor can also be further improve by adding more features such as LCD panel to display voltage, temperature etc. The PIC16F877 could be replace with a cheaper microcontroller such as PIC16F873 because the microcontroller have the same function and features while the dimension and size are smaller than PIC16F877. This is very important in development of low cost of ac adaptor. In order to further reduce size and cost, the ac adaptor should use a different topology with high frequency transformer.

ACKNOWLEDGMENT

I would like to express my deepest gratitude, appreciation and thanks to my supervisor, PM Tn Hj Ishak Bin Hj Ismail for his guidance, advices, encouragement and faith to me in accomplishing this project. I would also like to say thanks to my family and my friends NurHaryati, Raihan and Ismail for giving me encouragement and some help to complete this project.

REFERENCES

- [1] Maria D. Bellar, Tzong-Shiann Wu, Aristide Tchamdjau, Javad Mahdavi and M. Ehsani, "A Review of Soft-switched DC-AC Converter", IEEE trans. On Industry Appl, vol. 43, no. 4, pp 847-858, 1998.
- [2] Muhammad H. Rashid. "Power Electronics: Circuits, Devices and Applications", Third Edition, Pearson Prentice Hall, USA, 2004.
- [3] L. Mihalache. "DSP Control Method of Single - Phase Inverters for UPS Applications", IEEE Trans. On Industry Application. 2002, pp 590-595.
- [4] N. Mohan, T.M.Undeland, W.P.Robbins, "Power Electronic-Converters, Applications and Design", Second edition, John Wiley & Sons Inc., 1995.
- [5] Cyril W. Lander, "Power Electronics", Third edition, 1993.
- [6] N. Aphiratsakun, K. Techakittiroj & S. R. Bhaganagarapu, "Implementation of a Single Phase Unipolar Inverter Using

- DSP TMS320F241", Apr 2005, Faculty of Engineering, Assumption University Bangkok, Thailand.
- [7] J. Michael Jacob, Power Electronics: "Principles & Applications", Herrick & Jacob Series, Delmar, Thompson Learning, 2001.
- [8] Z. Salam & Khosru M. Salim, "Generation of Pulse Width Modulation (PWM) Signals for Three-Phase Inverter Using a Single Chip Microcontroller", Jun 2001, Jurnal Teknologi, Universiti Teknologi Malaysia.
- [9] Noorhafiza Bahro, "Simulation Of Single Phase Matrix Converter as a DC-AC Converter using MATLAB Simulink, November 2008", Faculty of Electrical Engineering, Universiti Teknologi MARA, Pulau Pinang Malaysia.
- [10] "PicBasic Pro Compiler", micro Engineering Labs. Inc, 2004.
- [11] PIC16F877 Data Sheet, PIC16F87x Device, Microchip [online], <http://www.microchip.com/download/lit/pline/picmicro/families/16f8xx.pdf> (Accessed: January 2009).
- [12] John G. Kassakian, Martin F. Schlecht, George C. Verghese, "Principle of Power Electronics", Addison-Wesley series, Addison-Wesley Publishing Company, Inc. 1991.
- [13] IR2181 Data Sheet, High and Low Side Driver, International Rectifier [online], <http://www.irf.com/product.info/datasheets/data/ir2181.pdf> (Accessed: August 2009).
- [14] P. T. Krein, Xin Geng and R. Balog, "High – Frequency Link Inverter Based on Multiple – Carrier PWM ", Grainger Center for Electric Machinery and Electromechanics, Department of Electrical and Computer Engineering, University of Illinois at Urbana – Champaign, USA.
- [15] Iovine, John, "PIC Microcontroller Project Book: For PIC Basic Pro Compilers", McGraw- Hill Professional, 2004.
- [16] Muhammad H. Rashid (editor in chief), "Power Electronics Handbook", Academic Press, Canada, 2001.
- [17] Application Note AN-978, HV Floating MOS-Gate Driver ICs, [online], <http://www.irf.com> (Accessed: Mac 2010).
- [18] M. Tabone, Cyril S. Staines, J. Cilia, " 'Low Cost' Three Phase to Single Phase Matrix Converter", University of Malta, Faculty of Engineering, Msida. MSD06, Malta.
- [19] IRF740 Datasheet, N - CHANNEL 400V - 0.48 W - 10 A - TO-220 Power MESHÔ MOSFET, [online], www.datasheetcatalog.com, (Accessed Jan 2010)
- [20] Omar M F Muhiaddin, Ahmad Nahas and Takyin Chan, " The Design and Implementation of a Three Phase Power Converter in the Power Electronics and Drives Subject" , School of Electrical Engineering, Victoria University, Australia.
- [21] Les Johnson, "Experimenting with the Picbasic Pro Compiler", Rosetta Technologies, A Crownhill Publication.