



اَبُو سَيِّدِي تَيَكُونُ لُو كِي مَبَارَا
**UNIVERSITI
 TEKNOLOGI
 MARA**

FUNDAMENTALS OF ENTREPRENUERSHIP (ENT300)

BUSINESS PLAN



- 1. 4
 - 2. 4
 - 3. 4
 - 4. 4
 - 5. 4
 - 6. 13
 - 7. 12
 - 8. 12
 - 9. 13
 - 10. 3
 - 11. 3
 - 12. 3
- 79

PREPARED BY:

DIPLOMA IN PUBLIC ADMINISTRATION

FACULTY OF ADMINISTRATIVE SCIENCE AND POLICY

GROUP: AM1104C

SEMESTER : 4

NAME	ID
ROMALDO ANTA ANAK AUGUSTINE	2017247964
ANASTHASIA TELANJING ANAK PETA	2017860272
JULIAN KRISTEN DAMIAN BAYANG	2017242468

PREPARED FOR: MDM SITI MARDINAH BINTI ABDUL HAMID

SUBMISSION DATE: 21ST MAY 2019

21/5/19

TABLE OF CONTENT

No	Title	Page
1	Cover	
2	Table of Content	
3	Business Proposal	
4	Company Cover	
5	Acknowledgement	
6	General Manager <ul style="list-style-type: none"> • Introduction to the Business • Purpose of Business Plan • Business Logo • Company Background • Business Partners Background • Location 	
7	Administration Manager <ul style="list-style-type: none"> • Organizational Mission and Vision • Organization chart • Manpower Planning • Schedule of tasks and responsibilities • Schedule of remuneration • List of Office Equipment • Organizational/Administration Budget 	
8	Marketing Manager <ul style="list-style-type: none"> • Introduction • Marketing Objectives • Product of Service Descripting • Target Market • Marketing Segmentation • Market Size • Competitors • Market Share • Sales Forecast • Marketing Strategy • Place for Distribution Strategies • Marketing Budget/Expenses 	
9	Operational Manager <ul style="list-style-type: none"> • Introduction • Objective • Process Planning • Operations Layout • Production Planning 	

	<ul style="list-style-type: none"> • Material Planning • Machine and Equipment Planning • Manpower Planning • Overheads Requirement • Location • Business and Operations Hours • License, Permits and Regulation Required • Operation Budget • Implementation Schedule 	
10	Financial Manager <ul style="list-style-type: none"> • Project Implementation Cost • Sources of Financing • Pro forma cash flow statement • Pro forma income statement • Pro forma balance sheet • Financial Analysis 	
11	Conclusion	
12	Appendix	

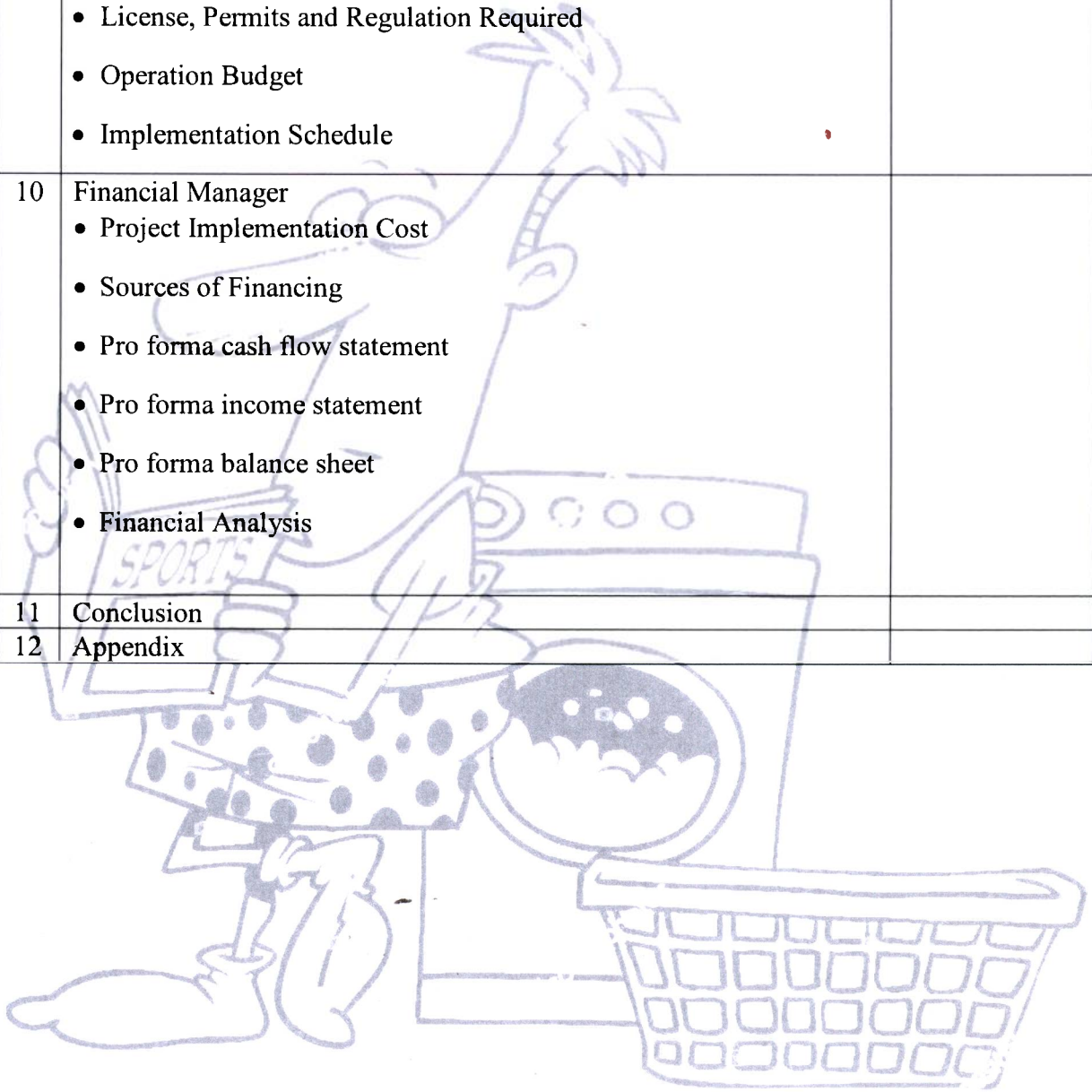

Diploma in Public Administration,
Faculty of Administrative Science and Policy
MARA University of Technology Sarawak,
Kota Samarahan Campus 2,
94300 Kota Samarahan,
SARAWAK

Madam Siti Mardinah Binti Abdul Hamid,
Lecturer of Fundamentals of Entrepreneurship (ENT300),
MARA University of Technology Sarawak,
Kota Samarahan Campus 2,
94300 Kota Samarahan,
SARAWAK
21st MAY 2019.

Dear Madam,

SUBMISSION OF BUSINESS PROPOSAL

Referring to the matter above, Serai's Laundry Services would like to submit our business plan for your analysis, evaluation and references. Serai's Laundry Services business partners and the site address are as mentioned below :

Details of partners are as follow:-

- | | |
|-----------------------------------|------------|
| 1. Romaldo Antak anak Augustine | 2017247964 |
| 2. Anasthasia Telanjing anak Peta | 2017860272 |
| 3. Julian Kristen Damian Bayang | 2017242468 |

Business address :

Serai's Laundry Services, 1st Floor, Jalan, 94300 Kota Samarahan, Sarawak

We hope our business plan will satisfy your requirement for our subject Fundamental of Entrepreneurship (ENT300). We also hope that our business plan will give huge benefit to those who are interested in doing the same business venture. Thank you.

You're faithfully,

.....
(ROMALDO ANTA ANAK AUGUSTINE)
GENERAL MANAGER Serai's Laundry Services

.....
(ROMALDO ANTA ANAK AUGUSTINE)
ADMINISTRATIVE MANAGER Serai's Laundry Services

.....
(ANASTHASIA TELANJING ANAK PETA)
MARKETING MANAGER Serai's Laundry Services

.....
(ANASTHASIA TELANJING ANAK PETA)
OPERATIONS MANAGER Serai's Laundry Services

.....
(JULIAN KRISTEN DAMIAN BAYANG)

FINANCIAL MANAGER Serai's Laundry Services



SERAI'S LAUNDRY SERVICES.



PREPARED BY:

- ROMALDO ANTA ANAK AUGUSTINE
- ANASTHASIA TELANJING ANAK PETA
- JULIAN KRISTEN DAMIAN BAYANG



GENERAL PLAN

INTRODUCTION TO BUSINESS

Our business name is Serai's Laundry Services. This business is based on partnership which is consist of three members which hold important positions in the company such as General Manager, Administrative Manager, Marketing Manager, Operation Manager, and Financial Manager. Our business is based on services.

Serai's Laundry Services is a company that provide laundry services. Nowadays, many students and staff are busy from their study and work and they do not have time in doing the laundry. So, that's the reason we open this business so that they can do their laundry whenever they have free time.

To operate this business, we open our business at UiTM Samarahan 2 which is located at Kota Samarahan, Sarawak.

PURPOSE OF BUSINESS PLAN

A business plan will enable the managers of Serai's Laundry Services to fully understand the proposed business. This will help the managers to evaluate and view the proposed business venture in an objective, critical, and business planning and also decision are also guided with the guidance of the availability of Business Plan.

Investors will need to fully comprehend the proposed venture before making any investment decision. Hence, the presence of Business Plan will assist potential investors in analysing and evaluating the viability of the project.

Business plan also used to convince relevant parties of the investment potential of the project and help the financial institution to evaluate the capability of the proposed project and provide loan for the business.

A business plan also helps the managers to manage the company by giving the guideline to them regarding their job duties and responsibilities. It is also helps to understand the businesses' goals and objectives of the business.

Business resources can be allocated effectively by having a business plan. This is to prevent the company from having more loss than profit and helps in the development of the company and also the business.

BUSINESS BACKGROUND

NAME OF THE BUSINESS	SERAI'S LAUNDRY SERVICES
BUSINESS ADDRESSES	UITM SAMARAHAN 2,9430, KOTA SAMARAHAN, SARAWAK
CORRESPONDENT ADDRESS	UITM SAMARAHAN 2,94300, KOTA SAMARAHAN, SARAWAK
WEBSITE ADDRESS	Serai'slaundryservices@gmail.com
EMAIL ADDRESS	serailaundryservices@gmail.com
TELEPHONE NUMBER	0198765432
FAX NUMBER	083987654
FORM OF BUSINESS	PARTNERSHIP
MAIN ACTIVITY	COIN LAUNDRY
DATE OF COMMENCEMENT	10/10/2020
DATE OF REGISTRATION	IN PROGRESS
REGISTRATION NUMBER	IN PROGRESS
NAME OF BANK	BANK ISLAM
BANK ACCOUNT NUMBER	1109876543212345

PARTNERS BACKGROUND

GENERAL MANAGER AND ADMINISTRATIVE MANAGER

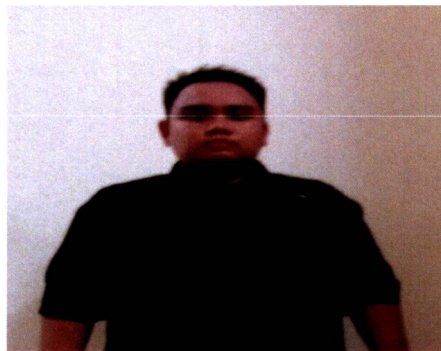

NAME	ROMALDO ANTAK ANAK AUGUSTINE KELIMBANG
IC NUMBER	991026065137
ADDRESS	TR GUMBANG, SG PELANDOK, PAKU, 95600 SPA OH, SARAWAK
CORRESPONDENT ADDRESS	TR GUMBANG, SG PELANDOK, PAKU, 95600 SPA OH, SARAWAK
EMAIL ADDRESS	romaldoantak13@gmail.com
TELEPHONE NUMBER	0102122232
DATE OF BIRTH	26/10/1999
AGE	20
MARITAL STATUS	SINGLE

ACADEMIC QUALIFICATION	DIPLOMA IN PUBLIC ADMINISTRATION
COURSE ATTENDED	NONE
SKILLS	GOOD IN COMMUNICATING. GOOD IN IT(MICROSOFT)
EXPERIENCE	CABIN CREW AT SINGAPORE CHICKEN RICE
CAPITAL CONTRIBUTION	RM 5000

FINANCIAL MANAGER

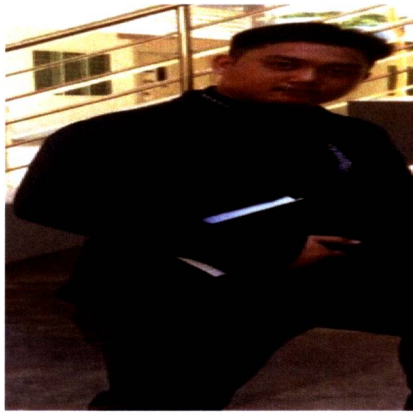

NAME	JULIAN KRISTEN DAMIAN BAYANG
IC NUMBER	991223136061
ADDRESS	NO28, BEVERLY GARDEN, 93250, KUCHING, SARAWAK
CORRESPONDENT ADDRESS	NO28, BEVERLY GARDEN, 93250, KUCHING, SARAWAK
EMAIL ADDRESS	Juliankristendamianbayang99@gmail.com
TELEPHONE NUMBER	0109656254

DATE OF BIRTH	23/12/1999
AGE	20
MARITAL STATUS	SINGLE
ACADEMIC QUALIFICATION	DIPLOMA IN PUBLIC ADMINISTRATION
COURSE ATTENDED	ACCA
SKILLS	FLYING FINGERS, MUSICAL INSTRUMENT
EXPERIENCE	CABIN CREW AT MCDONALDS
CAPITAL CONTRIBUTION	RM 5000

MARKETING AND OPERATING MANAGER



NAME	ANASTHASIA TELANJING ANAK PETA@PETER
IC NUMBER	990906135266
ADDRESS	LOT 744,JALAN ABANG AMIN,96500,BINTANGOR,SARAWAK
CORRESPONDENT ADDRESS	LOT 744,JALAN ABANG AMIN,96500,BINTANGOR,SARAWAK
EMAIL ADDRESS	anasthasiatelanjing@gmail.com
TELEPHONE NUMBER	0109755478
DATE OF BIRTH	6/9/1999
AGE	20
MARITAL STATUS	SINGLE
ACADEMIC QUALIFICATION	DIPLOMA IN PUBLIC ADMINISTRATION
COURSE ATTENDED	NONE
SKILLS	IT SKILLS(MICROSOFT)
EXPERIENCE	CABIN CREW AT MARRYBROWN
CAPITAL CONTRIBUTION	RM 5000

BUSINESS LOCATION

FACTORS INFLUENTING CHOICE OF BUSINESS LOCATION

The price of the rental is about RM 800 monthly. This price is reasonable as it is within our budget. Furthermore, the prices is suitable since the rate of economy is increasing.

The shop are also located near to our source of raw material that is at Summer Mall Shopping Complex which takes around 10 minutes from our shop by car. So it is easy for us to buy our materials incase we are short of materials. With that, we can reduce our cost of delivering as we can go there by ourselves.

The reason we choose to open our shop at UITM Samarahan 2 is because so that students did not waste their time to go to other laundry outside the campus. It also can save their budget since they just can go to our shop by foot instead of using transportation such as Grab and others.



*ADMINISTRATIVE
MANAGER*

ADMINISTRATION PLAN

INTRODUCTION TO THE ORGANIZATION

VISION AND MISSION

Our brand, Serai's Laundry Services will be providing the cheapest yet making profit laundry and made students and staff life easier.

ORGANIZATIONAL CHART

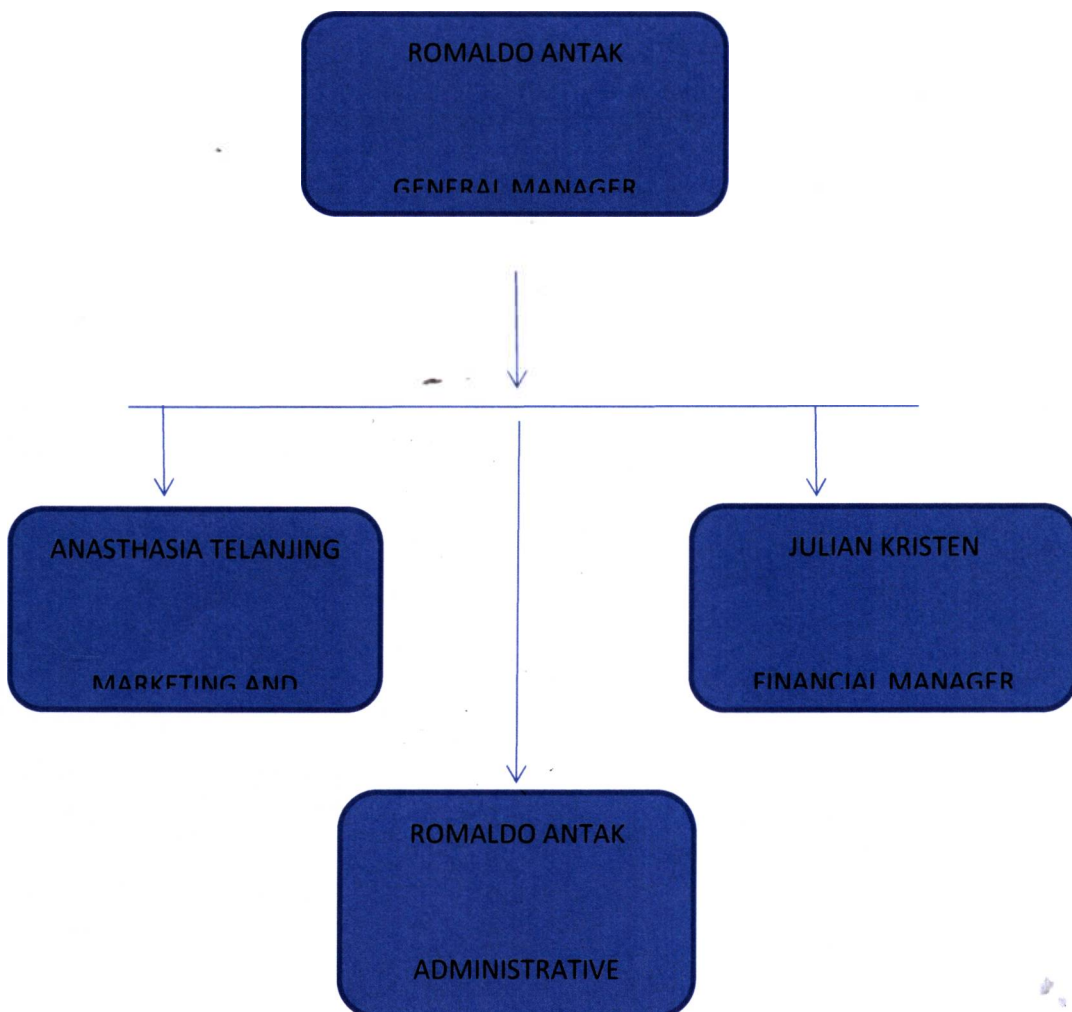

ADMINISTRATIVE MANPOWER PLANNING

TABLE 1: POSITION AND NUMBER OF PERSONNEL

POSITION	NUMBER OF PERSONNEL
GENERAL MANAGER	1
ADMINISTRATIVE AND FINANCIAL MANAGER	1
MARKETING AND OPERATING MANAGER	1
STAFF	4
TOTAL	7

SCHEDULE OF TASKS AND RESPONSIBILITIES

TABLE 2: SCHEDULE OF TASKS AND RESPONSIBILITIES

Position	Tasks and Responsibilities
General Manager	<ul style="list-style-type: none"> ● To ensure the business runs smoothly and under control. ● Able to communicate and cooperate well with peoples and other managers. ● To form objectives, planning strategies and monitor the organisation policies and also as mastermind in this business. ● Alert in the management and business operation to avoid any disturbance that may occur during the business.
Administration Manager	<ul style="list-style-type: none"> ● Help GM manage and plan the business to ensure the business run systematically. ● To plan administration system so that the business run efficiently and effectively. ● To ensure all the short-term and long-term objectives will be achieve. ● To prepare a good budget to determine the overall budget in the business. ● Responsible to list the wages and salaries of every employee that help to run the business.
Marketing Manager	<ul style="list-style-type: none"> ● To promote the business to customers and to find potential

	<p>customers to increase sales.</p> <ul style="list-style-type: none"> ● To prepare marketing analysis and observe some location to expand the business. ● To make sure the customers are satisfied with the products. ● To identify marketing target, current market and determine the most suitable strategy to be used in ensure the maximum profit. ● Helps to create more ideas to make sure the customers are well attracted to the business.
Operational Manager	<ul style="list-style-type: none"> ● To ensure there is no shortage of supply in stock. ● Able to know amount of raw materials needed in each machine. ● To ensure the end product and services fulfill the customers' satisfaction.
Financial Manager	<ul style="list-style-type: none"> ● To prepare cash flow, trading profit, loss account and balance sheet of the business. ● Responsible for all financial activities in the business. ● Helps to handle the administration, operational, and marketing expenses in order for the business to be financially stable. ● To identify the relevant sources of finance. ● To estimate the ratios to determine the profit per month.

SCHEDULE OF REMUNERATION

Position	No	Monthly salary(RM)	EPF contribution (RM)	SOCSSO (RM)	Amount(RM)
General Manager & Administrative Manager	1	2500	325	57.50	2117.50
Marketing & Operational Manager	1	2000	260	46	1694
Financial Manager	1	2000	260	46	1694
TOTAL	3	6500	845	149.50	5505.50

Compensation and Benefits

1. Salary, EPF, SOCSSO

2. Maternity leave, Paternity leave
3. Bonus
4. Annual Leave
5. Working days
6. Others

ADMINISTRATIVE BUDGET

FIXED ASSETS	RM
Store furniture , Fixtures, Fittings	800
Store equipments	300
WORKING CAPITAL	

Salary	5005
EPF(13%)	845
SOCOSO(2.3%)	150
Wi-Fi	120
Building rent*	500
Bill	320
Office supplies	50
PRE- OPERATIONS	
Deposit(rent,utilities,etc)	200
Business registration & license	100
TOTAL	8690

OFFICE LAYOUT

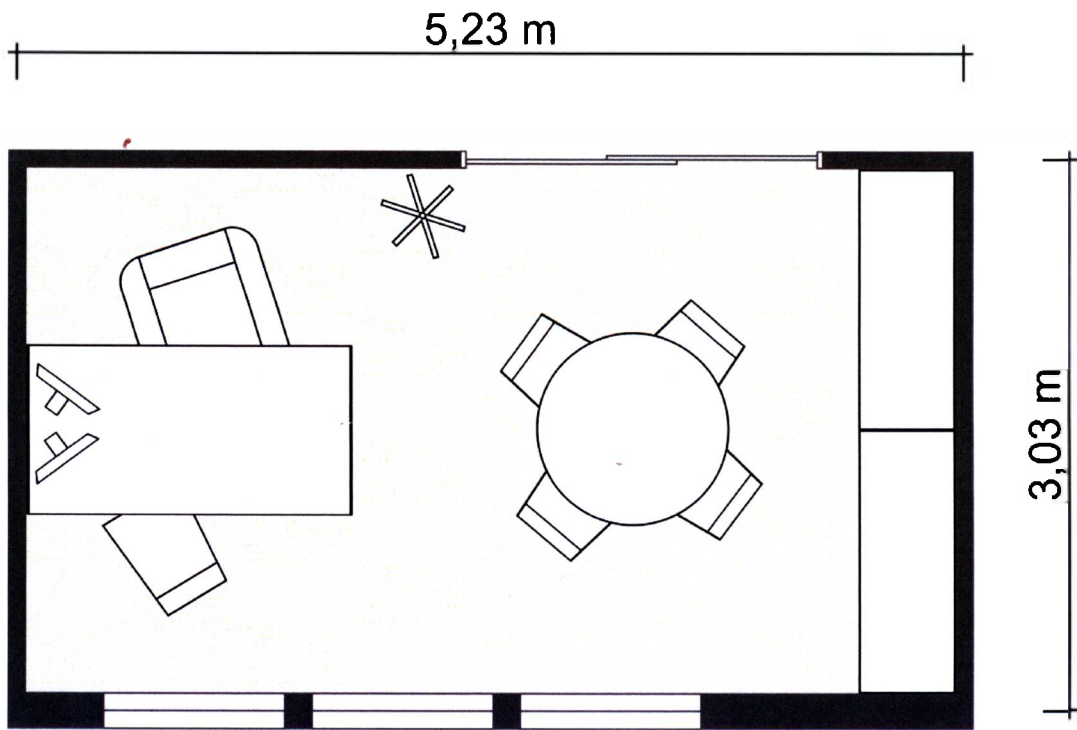

4.3 Operation Layout

Main

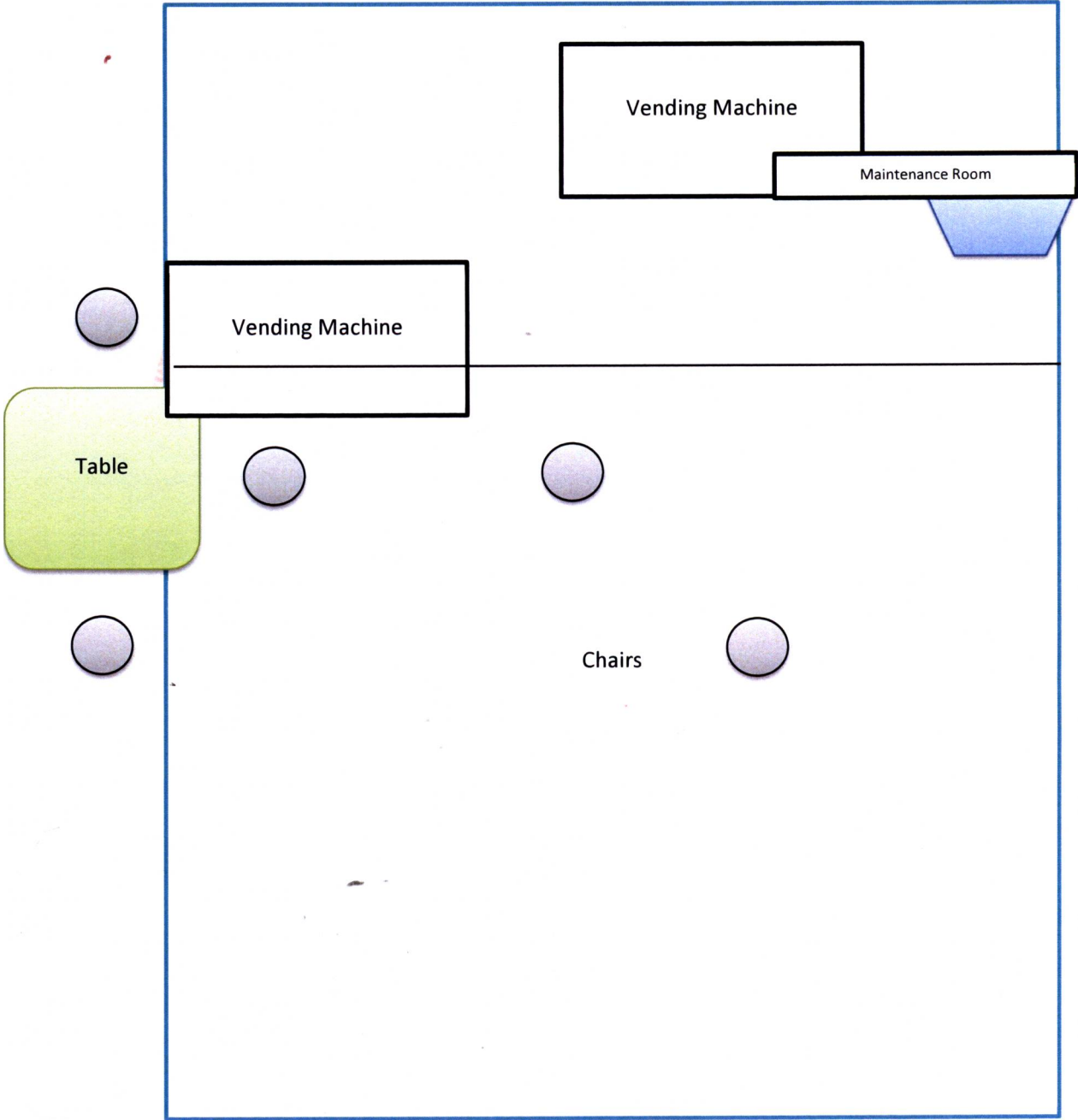

MARKETING

PLAN



INTRODUCTION TO MARKETING

Marketing can be defined as the process of planning and executing the conception, pricing, promotion, and distribution of ideas, goods and services to create exchange that satisfying individual and organization objectives. Marketing is one most important part in running up a business. Without a well planned marketing plan, business may never achieve its goals and resources such as money, energy and time can be wasted. These also might leads the business to bankrupt.



The basic idea of marketing is basically an exchange activity that takes places between a business entity and its customer. These customers include individual, business entity, and also the support organizations. Marketing is a crucial aspects in business and always referred as the backbone to any business in achieving a profitable outcome.

In our business, we are introducing our laundry services that different from other laundries at Kota Samarahan.

Marketing objectives support the achievement of a business mission and vision:

- Establish sustainable business by the end of the first year.
- Produce net profits.

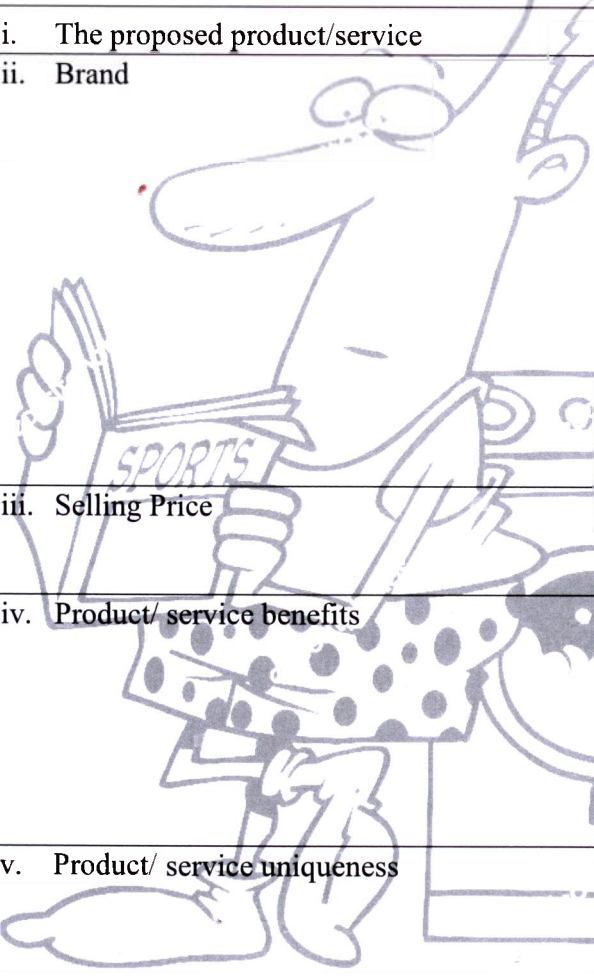
INTRODUCTION TO PRODUCT OR SERVICE

i. The proposed product/service	The proposed of our services
ii. Brand	
	 <p style="text-align: center;">SERAI'S LAUNDRY SERVICES.</p>
iii. Selling Price	<p>RM 5.00 for laundry RM 5.00 for drying</p>
iv. Product/ service benefits	<p>As our cafe is located at Jalan Desa Ilmu and it is easier for Unimas and UiTM students and lecturers along with those who live near Kota Samarahan to come to our laundry services</p>
v. Product/ service uniqueness	<p>Our laundry services provide pick up and delivery the laundry from student's location.</p>
vi. List of product or service (if appropriate)	<p>CLEANING: To helps or to prevent the spread of germs found on clothes.</p> <p>DRY CLEANING: Serai's Laundry Services offers a full dry cleaning service to help keep your clothing look fresh and new. Our dry cleaning service can even extend the life of your garments and prevent shinkage and colorless much better than traditional wet washing.</p>

Market area and business location

Our market area and business location is located at Jalan Desa Ilmu. As it is located at Jalan Desa Ilmu, we believed that it is the most strategic place to open a business because it is the centre of the Kota Samarahan where most students would to spend their leisure time or to go shopping because it is near Aiman Mall for most of their needs.

Segmenting the market

1. Geographic Segmentation

- Residents of Kota Samarahan.
- Students of higher learning institutions who studying at UiTM Kota Samarahan and UNIMAS

2. Demographic Segmentation

- Lower and middle income class

3. Psychographic

- Prefer affordable price for students
- Prefer new ways of services.

Therefore, Serai's Laundry Services target market are consist of lower and middle income residents of Desa Ilmu, Kota Samarahan and also students of UiTM Kota Samarahan and UNIMAS in Kota Samarahan who prefer affordable price for students and prefer new ways of services such as pick up and delivery the laundry.

TARGET MARKET

Serai's Laundry Services is a business of laundry servicing to the people of Kota Samarahan because it is where our business is located. The location of our business is strategic because it is the shopping area for most of the university students and residents of Kota Samarahan. University students from UNIMAS or UiTM Kota Samarahan always consider Desa Ilmu is a strategic place because it is nearby food stalls, mall and bank. Therefore, our main target market is the university students of UNIMAS and UiTM Kota Samarahan and residents of Desa Ilmu, Kota Samarahan.

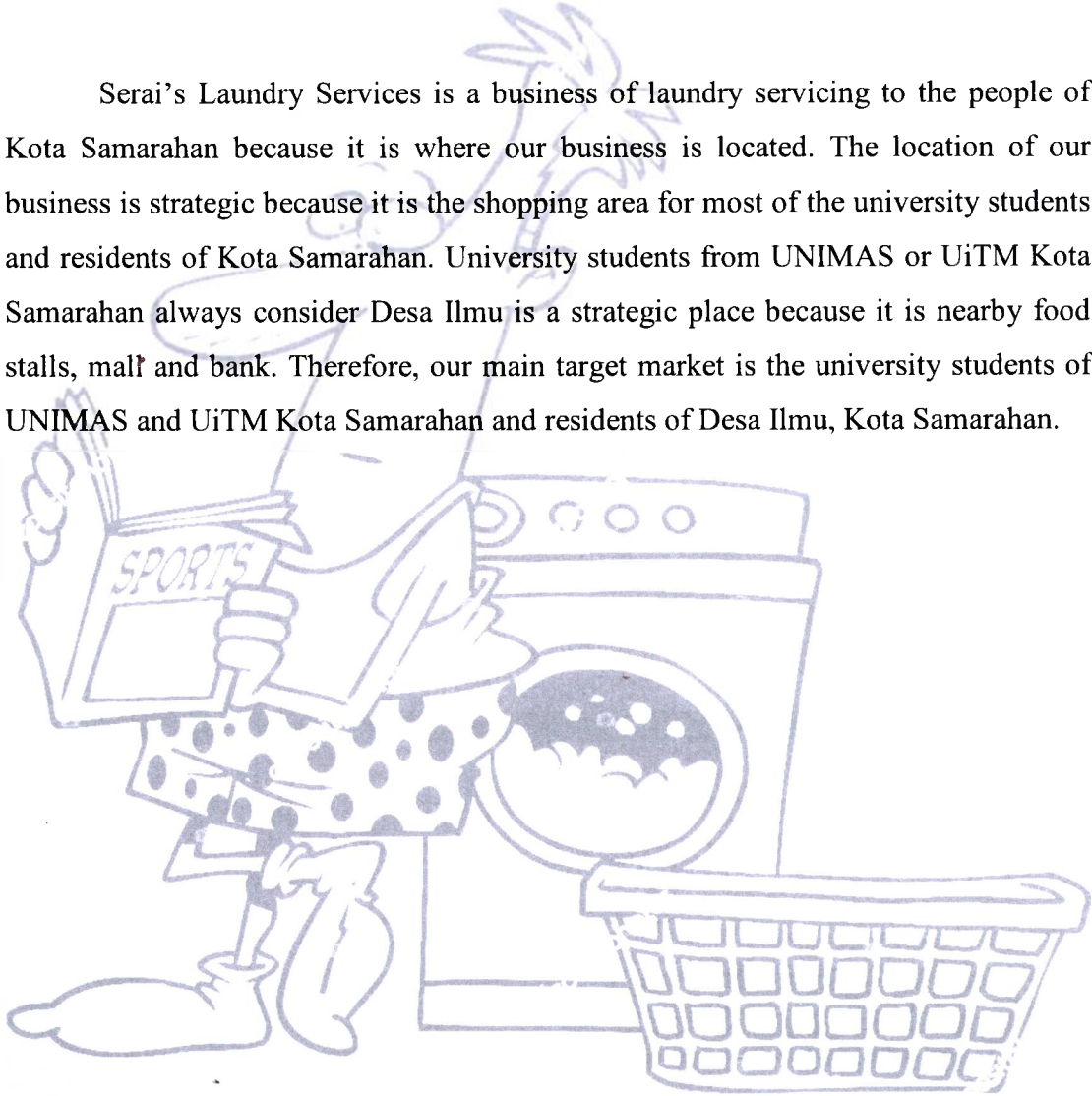

MARKET SIZE

Market size is the total potential purchase that is expected from the target market. It is the potential purchase includes purchases of the competitor's product within the same market. Before launching a new product or services, it is important to know the market size. The precision is very important in determining the measurement in market price.

The market size often quoted in unit of sales (quantity) or sales (which would be in RM) or both for a specific period; daily, weekly, monthly or yearly.

Below is the market size;

Table 6: Market size

Market Segment	Population	Target Market (%)	Target Market
Teenagers (50% OF 2000)	1000	40	400
Families (25% OF 2000)	500	20	100
Adult (25% OF 2000)	500	40	200

Market Segment	Target Market	Potential Purchase (RM)	Total Potential Purchase (monthly) (RM)
Teenagers	400	15//week	(RM15 x 4 weeks) x 400 = 24,000
Families	100	50/month	RM 50 x 100 = 5,000
Adults	200	30/week	(RM30 x 4 weeks) x 200 = 24,000
Total			RM51,000

Market size per year = RM 612,000 (RM51,000 x 12)

COMPETITORS

Competitors refer to other businesses that offer similar products, substitute or alternative products or services to the same target market. Among all of the laundry services existed, these three are the biggest competitors among all of those that are located in Samarahan and Kuching area.

Analysis of Competitor

Table 7: Competitor Strengths and Weaknesses

Competitors	Strengths	Weakness
MAMA DOBI	<ol style="list-style-type: none"> 1. Door-to-door service 2. Quick and convenient 3. Resonable prices 	<ol style="list-style-type: none"> 1. No profit making because it is the new business. 2. Small form of business.
LAUNDROMAT	<ol style="list-style-type: none"> 1. Attractive discount program 2. Business's owner can quickly receive pay. 	<ol style="list-style-type: none"> 1. No experiences. 2. Costs of transferring delivering service are limited.
LAUNDRYBAR	<ol style="list-style-type: none"> 1. Door-to-door service 2. More discount for student and regular customers. 3. Business's owner do not need in-depth business 	<ol style="list-style-type: none"> 1. Small form of business. 2. Washing machine not proper in use.

Analysis of "Flamenco Coffee Cafe" Opportunities and Threats

Table 8: Business Opportunities and Threats

Opportunities	Threats
<ol style="list-style-type: none"> 1. Other competitors: Bigger laundry services and other new business that enters the business world. 2. No profit in first month. The cost of machine is high so there cannot be no profit for first month. 	<ol style="list-style-type: none"> 1. Laundry price is cheaper than others which help to attract more customers. 2. Opportunity business from busy people who do not have time to do their laundry.

Market Share

Market share refers to the percentage of a company's total sale earned over the specified time period. The market share is calculated by taking the company's sales over the period and dividing it by the total sales of the company over the same period.

Below are the analysis of the market share of Serai's Laundry Services before and after their entry.

Market Share before entry of "Serai's Laundry Services"

Market Share before entry of "Flamenco Coffee Cafe"

Table 9: Market Share before entrance

Competitors	Market Share (RM)	Market Share/ yearly (RM)
MAMA DOBI	40	244,800
LAUNDROMAT	25	153,000
LAUNDRYBAR	35	214,200
Total	100	612,000

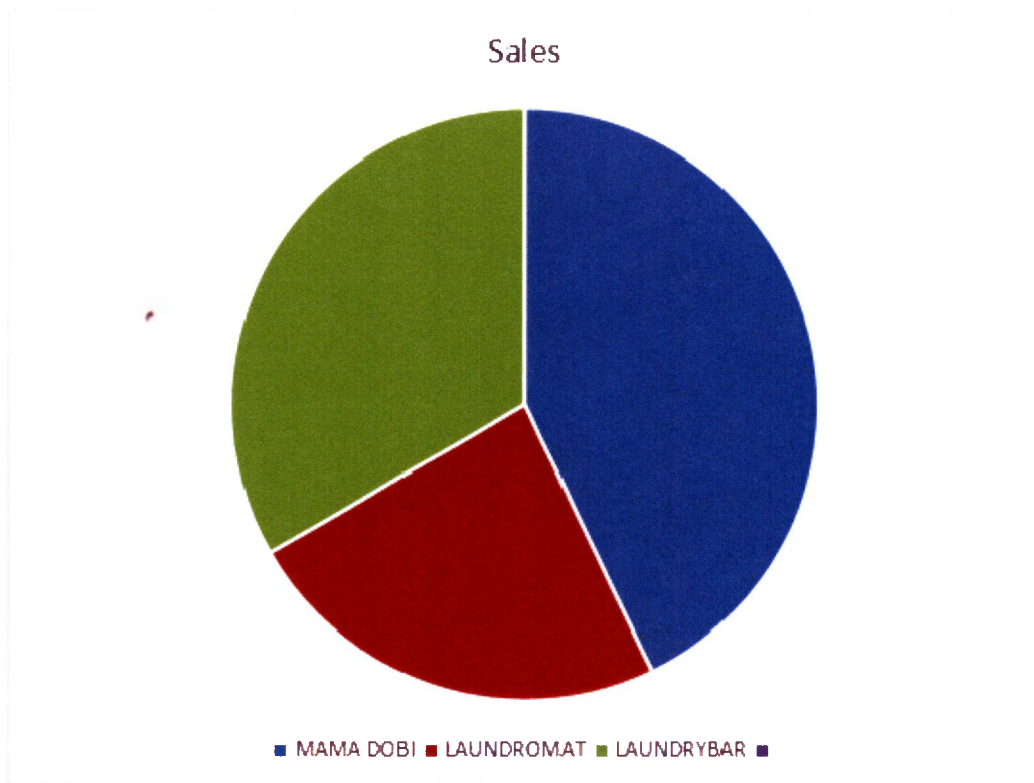

Market Share after entry of “Flamenco Coffee Cafe”

Table 9: Market Share after entrance

Competitors	Market Share (%)	Lost of Market Share (%)	Market Share (%)	Market Share/ yearly (RM)
MAMA LAUNDRY	40	5	30	183,600
LAUNDROMAT	25	3	22	13,464
LAUNDRYBAR	35	2	23	140,760
SERAI LAUNDRY	-	-	25	153,000
Total	100	10	100	612,000

Sales

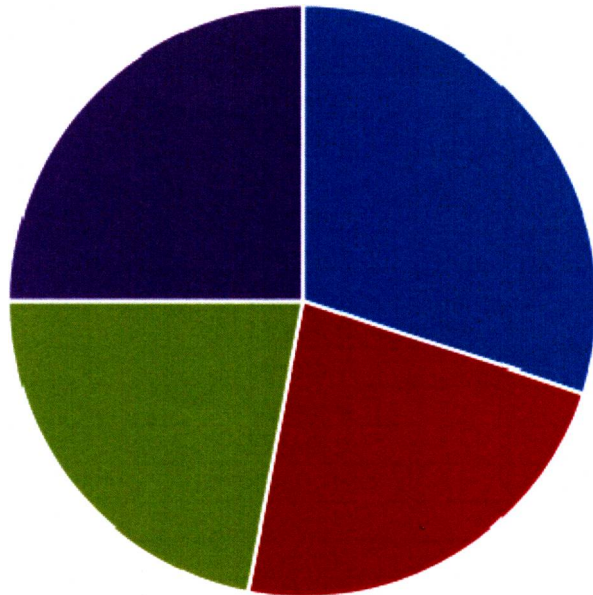

■ MAMA DOBI ■ LAUNDROMAT ■ LAUNDRY BAR ■ SERAI LAUNDRY

SALES FORECAST

SALES PROJECTION/ FORECAST		
Year	Month	Sales Collection
	Month 1	12,750
	Month 2	12,750
	Month 3	12,750
	Month 4	12,750
	Month 5	12,750
	Month 6	12,750
	Month 7	12,750
	Month 8	12,750
	Month 9	12,750
	Month 10	12,750
	Month 11	12,750
	Month 12	12,750
2017	Total Year 1	153,000
2018	Total Year 2 (increase by 3%)	157,590
2019	Total Year 3 (increase by 3%)	162,180

Table 10: Sales Forecast for three consecutive years

CASH COLLECTIONS FOR SALES	
In the month of sale	30%
1 month after sale	20%
2 month after sale	50%
-Total	100%

MARKETING STRATEGY

Product or service strategy

Brand

Our laundry services is name Serai's Laundry Services which offer laundry services. As our laundry named Serai so we use detergent 20% of lemongrass inside and because lemongrass many benefits such as can get rid of smells.

Design

Product design or service package plays an important role in satisfying and delighting the target market. Our services would design the detergent packaging and softener, and also laundry bag with different size such as small, medium, large, and extra large so that the people who come to our laundry no need to bring their basket. Not only that our shop also can attract the eyes of customers which is we design our shop full of doodles at the wall because we need to fulfill the customers wants and set in mind that customer is always right.

Packaging

- Protection

The primary function of packaging is to protect the services during the process of transportation to pick up and delivery the laundry we need to make sure there is no tearing, missing and got holes at the shirt. So we choose transparent plastics as our packager. In addition, it is easiest way for the customer to see.

- Attractive to customer

The packaging of the product may be the sellers' final chance to influence customers.

Price strategy

The definite meaning of the price of a product or service is the amount of money product, how much we can sell, and what market share will get in relation to competitors. Objectives such as these and how a business generates profit in comparison to the cost of production need to be taken into account when selecting the right pricing strategy. There are several pricing strategies, namely, cost based pricing, value based pricing, and competition based pricing, however for our company, we have decided to imply the cost based pricing strategy. charged to the customer for a particular purchase.

Price for Washing Machine

$$\begin{aligned}\text{Service Cost} &= \text{Electricity} + \text{Detergent and Soap} + \text{Mark up cost} \\ &= (3.00 + 1.00) + 1.00 \\ &= \text{RM } 5.00\end{aligned}$$

Price for Dryer

$$\begin{aligned}\text{Service cost} &= \text{Electricity Bill} + \text{Mark up cost} \\ &= (1.50 + 0.50) + 0.50 \\ &= \text{RM } 2.50\end{aligned}$$

Marketing Budget

MARKETING BUDGET	
Fixed Assets	RM
Signboard	1,500
Store furniture, Fixtures, Fittings	1100
Store equipment	120
Working Capital	
Marketing personnel	1100
Office supplies	130
Other Expenditure	
Other Expenditure	150
Pre-Operations	

Deposit (rent, utilities, etc.)	
Business Registration & Licences	
Insurance & Road Tax for Motor Vehicle	
Other Expenditure	
TOTAL	4,100



OPERATIONAL



OPERATIONAL PROCESS

1. Receive the raw material of laundry.
2. Put the raw materials such as detergent, softener, soap into the washing machine.
3. Provide the coin changer so that customer can easily change their money.
4. Provide basket for the customer
5. Provide table for the customer so that they can fold their laundry.
6. Provide washing machine on the bottom and put the dryer on top of it.

FLOW CHART

CUSTOMER PUT THEIR LAUNDRY INTO THE WASHING MACHINE



CUSTOMER CHOOSE THEIR TEMPERATURE OF WATER



CUSTOMER PUT THE TOKENS INSIDE THE MACHINE AND THE WASHING STARTS



AFTER THAT, CUSTOMER PUT THE LAUNDRY INSIDE THE DRYER AND CHOOSE THE TEMPERATURE



AFTER THAT, CUSTOMER FOLDS THEIR LAUNDRY ON THE TABLE PROVIDED

FLOOR PLAN

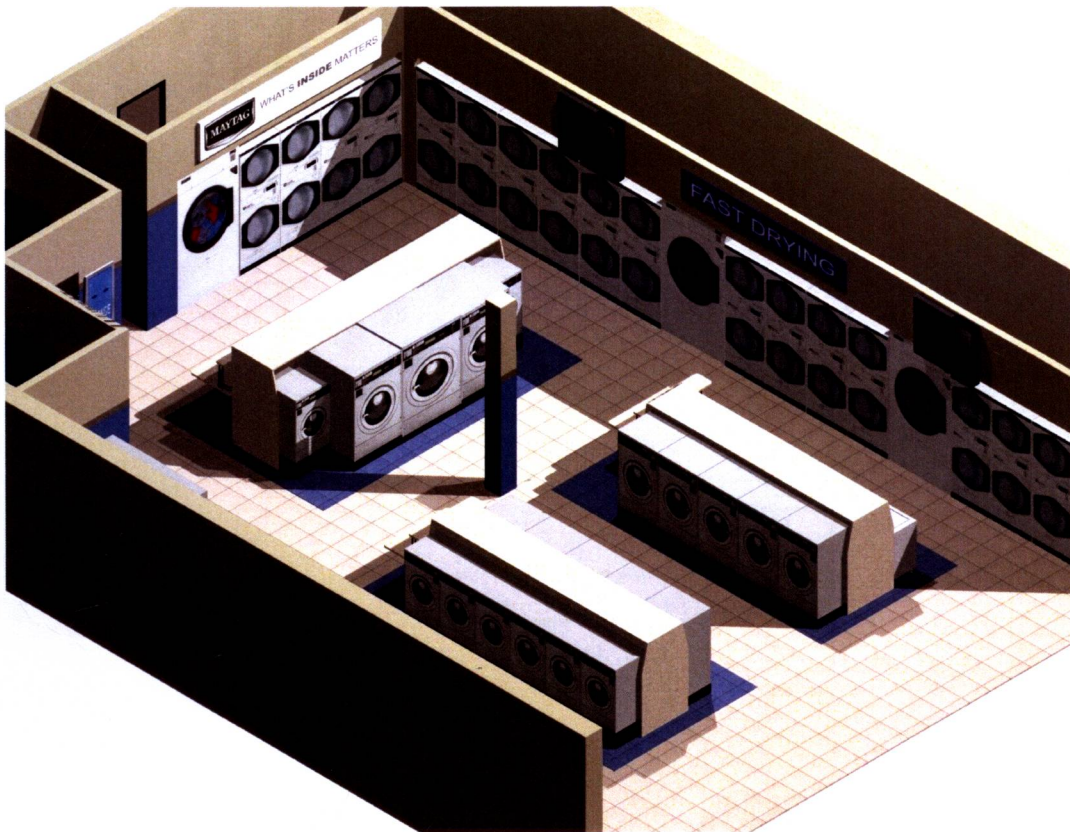



*FINANCIAL
MANAGER*

FINANCIAL PLAN

A financial plan incorporates all financial data derived from the operating budget, marketing budget and administration budget. It also includes various financial statement that show where your company currently is financially and where it intends to be. So financial plan can be budget, a plan of spending and saving future income. Financial helps you determine how much financing your business needs and it also allocates future income to various types of expenses such as rent, utilities, and also reserves some income for short term and long term saving.

In business, based on the financial data, projections are prepared via the cash flow, income or profit and loss statement and balance sheet created within a business plan. Financial plan also can be defined as an annual projection of income and expenses for a company ,division or department. It can help the manager determine if they can achieve the organization goal. The financial plan is one of the first things created to help managers make decisions that are in the best interest of the organization such as through borrowing or issuing additional shares in a company. So this will help the company grow well and can compete with other company.

We could say that financial plan can be defines as a the task of determining how the organization will afford to achieve its strategic goal by estimating future income, expenses and assets, a financing plan which are to cover the future expenses , for instance through earning , borrowing or using saved cash.

The objectives of the financial plan are as follows:

Determining capital requirements- This will depend upon factors like cost of current and fixed assets, promotional expenses and long- range planning. Capital requirements have to be looked with both aspects: short- term and long- term requirements.

Determining capital structure- The capital structure is the composition of capital, i.e., the relative kind and proportion of capital required in the business. This includes decisions of debt- equity ratio- both short-term and long- term.

Framing financial policies with regards to cash control, lending, borrowings, etc.

A finance manager ensures that the scarce financial resources are maximally utilized in the best possible manner at least cost in order to get maximum returns on investment.

Administrative Budget

ADMINISTRATIVE BUDGET	
Fixed Assets	RM
Land & Building	
Store furniture, Fixtures, Fittings	800
Store equipment	300
Working Capital	
Salary	5005
EPF (13%)	845
SOSCO (2.3)	150
Wi-Fi	120
Building Rent	500
Bill	320
Office supplies	50
Other Expenditure	
Other Expenditure	
Pre-Operations	
Deposit (rent, utilities, etc.)	200
Business Registration & Licences	100
Insurance & Road Tax for Motor Vehicle	
Other Expenditure	
TOTAL	8,690

Marketing Budget

MARKETING BUDGET	
Fixed Assets	RM
Signboard	1,500
Store furniture, Fixtures, Fittings	1100
Store equipment	120
Working Capital	
Marketing personnel	1100
Office supplies	130

Other Expenditure	
Other Expenditure	150
Pre-Operations	
Deposit (rent, utilities, etc.)	
Business Registration & Licences	
Insurance & Road Tax for Motor Vehicle	
Other Expenditure	
TOTAL	4,100

OPERATING BUDGET

OPERATIONS EXPENDITURE	
Fixed Assets	RM
Machinery and equipment	7,000
Secondhand-Car	3,000
Working Capital	
Raw Materials (Detergent and Soap)	500
Carriage Inward & Duty	
Salaries, EPF & SOCSO	2,400
Vending machine products	300
Other Expenditure	
Other Expenditure	
Pre-Operations	
Deposit (rent, utilities, etc.)	
Business Registration & Licences	
Insurance & Road Tax for Motor Vehicle	150
Other Expenditure	
TOTAL	13,350

PROJECT IMPLEMENTATION COST

SERAI LAUNDRY SERVICES					
PROJECT IMPLEMENTATION COST & SOURCES OF FINANCE					
Project Implementation Cost		Sources of Finance			
Requirements	Cost	Loan	Hire-Purchase	Own Contribution	
				Cash	Existing F. Assets
Fixed Assets					
Land & Building					
Store furniture, Fixtures, Fittings	800			800	
Store equipment	300			300	
Signboard	1,500			1,500	
Store furniture, Fixtures, Fittings	1100	100		1000	
Store equipment	120			120	
Machinery and equipment	7000			7000	
Secondhand-Car	3000			3000	

Working Capital	1 months				
Administrative		7370	370	7000	
Marketing		1,230	230	1000	
Operations		3,200	200	3,000	
Pre-Operations & Other Expenditure		250		250	
Contingencies	5%	1,247	1247		
TOTAL		27,117	2147	24,970	

SOURCES OF FINANCE

EQUITY	(RM)	Total (RM)
CASH CONTRIBUTIONS :		
Romaldo Antak anak Augustine		

(General Manager)	5,000	
(Administrative Manager)		
Anasthasia Telanjing Anak Peter (Marketing Manager) (Operational Manager)	5,000	
Siti Nur Marhamah Binti Zainuddin (Financial Manager)	5,000	15,000
Existing Fixed Assets		
Secondhand Car		3,000
External Sources		
Term Loan (MayBank)	50,000	50,000
Total Sources of Finance		RM68,000

DEPRECIATION SCHEDULE

Fixed Asset		Store furniture, Fixtures, Fittings	
Cost (RM)		800	
Method		Straight Line	
Economic Life (yrs)		3	
<i>Year</i>	<i>Annual Depreciation</i>	<i>Accumulated Depreciation</i>	<i>Book Value</i>
	-	-	800
1	266.67	266.67	533.33
2	266.67	533.33	266.67
3	266.67	800	-

Fixed Asset		Store equipment	
Cost (RM)		3,199	
Method		Straight Line	
Economic Life (yrs)		3	
<i>Year</i>	<i>Annual Depreciation</i>	<i>Accumulated Depreciation</i>	<i>Book Value</i>
	-	-	300
1	100	100	200

2	100	200	100
3	100	300	-

Fixed Asset Signboard			
Cost (RM) 1,500			
Method Straight Line			
Economic Life (yrs) 3			
	<i>Annual</i>	<i>Accumulated</i>	
<i>Year</i>	<i>Depreciation</i>	<i>Depreciation</i>	<i>Book Value</i>
	-	-	1,500
1	500	500	1,000
2	500	1,000	500
3	500	1,500	-

Fixed Asset	Store furniture, Fixtures, Fittings
Cost (RM)	1,100
Method	Straight Line

Economic Life (yrs) 3			
<i>Year</i>	<i>Annual Depreciation</i>	<i>Accumulated Depreciation</i>	<i>Book Value</i>
	-	-	1,100
1	366.67	366.67	733.33
2	366.67	733.33	366.67
3	366.67	1,100	-

Fixed Asset Store equipment			
Cost (RM)		120	
Method		Straight Line	
Economic Life (yrs) 3			
<i>Year</i>	<i>Annual Depreciation</i>	<i>Accumulated Depreciation</i>	<i>Book Value</i>
	-	-	120
1	40	40	80
2	40	80	40
3	40	120	-

Fixed Asset		Machinery and equipment	
Cost (RM)		7,000	
Method		Straight Line	

Economic Life (yrs) 3			
Year	Annual Depreciation	Accumulated Depreciation	Book Value
	-	-	7,000
1	2333.33	2333.33	4,666.66
2	2333.33	4666.66	2333.33
3	2333.33	7000	-

Fixed Asset Secondhand Car			
Cost (RM)		3,000	
Method		Straight Line	
Economic Life (yrs) 3			
Year	Annual Depreciation	Accumulated Depreciation	Book Value
	-	-	3000
1	1,000	1,000	2000
2	1,000	2,000	1000
3	1,000	3,000	-

LOAN REPAYMENT SCHEDULE

Amount	25,549			
Interest Rate	2%			
Duration (yrs)	3			
Method	Baki Tahunan			
Year	Principal	Interest	Total Payment	Principal Balance
	-	-	-	2,147
1	715.67	42.94	758.61	1431.34
2	715.67	28.63	744.35	715.67
3	715.67	14.31	729.98	-

PRO-FORMA PRODUCTION STATEMENT

SERAI LAUNDRY SERVICES
PRO-FORMA INCOME STATEMENT

	Year 1	Year 2	Year 3
Sales	153,000	157,590	162,180
Less: Cost of Sales			
Opening stock			
Purchases	9,600	9,600	9,600
Less: Ending Stock			
Carriage Inward & Duty			
Gross Profit			
Less: Expenditure			
Administrative Expenditure	91,080	91,080	91,080
Marketing Expenditure	1,800	1,800	1,800
Other Expenditure			

Business Registration & Licences	100		
Insurance & Road Tax for Motor Vehicle	150	150	150
Other Pre-Operations Expenditure			
Interest on Hire-Purchase			
Interest on Loan	42.94	28.63	14.31
Depreciation of Fixed Assets	715.67	715.67	715.67
Operations Expenditure	150	150	150
Total Expenditure	103,638.61	103,638.61	103,638.61
Net Profit Before Tax	49,361.39	53,951.39	58,541.39
Tax	0	0	0
Net Profit After Tax	49,361.39	53,951.39	58,541.39
Accumulated Net Profit	49,361.39	53,951.39	58,541.39

SERAI LAUNDRY SERVICES
PRO-FORMA BALANCE SHEET

	Year 1	Year 2	Year 3
ASSETS			
Non-Current Assets (Book Value)			
Land & Building			
Store furniture, Fixtures, Fittings	2,133	1,067	
Store equipment	2,133	1,066	
Signboard	667	333	
Store furniture, Fixtures, Fittings	2,133	1,067	
Store equipment	1,133	566	

Machinery and equipment	13,835	6,918	
Secondhand Car	9,200	4,600	
Other Assets			
Deposit			
	31,234	15,617	
Current Assets			
Stock of Raw Materials	0	0	0
Stock of Finished Goods	0	0	0
Accounts Receivable	195,000	214,500	235,950
Cash Balance	1,203,874	2,691,949	4,392,745
	1,398,874	2,906,449	4,628,695
TOTAL ASSETS	1,430,108	2,922,066	4,628,695
Owners' Equity			
Capital	96,098	96,098	96,098
Accumulated Profit	1,289,965	2,790,439	4,505,584
	1,386,063	2,886,537	4,601,682
Long-Term Liabilities			
Loan Balance	17,033	8,516	
Hire-Purchase Balance			
	17,033	8,516	
Current Liabilities			
Accounts Payable	27,013	27,013	27,013
TOTAL EQUITY & LIABILITIES	1,430,108	2,922,066	4,628,695

PRO-FORMA CASH FLOW STATEMENT

**SERAI LAUNDRY SERVICES
PRO FORMA CASH FLOW STATEMENT**

MONTH	Pre-Operations	1	2	3	4	5	6	7	8	9	10	11	12	TOTAL YR 1	YEAR 2	YEAR 3
<u>CASH INFLOW</u>																
Capital (Cash)	82,298													82,298		
Loan	25,549													25,549		
Cash Sales		48,750	48,750	48,750	48,750	48,750	48,750	48,750	48,750	48,750	48,750	48,750	48,750	585,000	643,500	707,850
Collection of Accounts Receivable			32,500	113,750	113,750	113,750	113,750	113,750	113,750	113,750	113,750	113,750	113,750	1,170,000	1,482,000	1,630,200
TOTAL CASH INFLOW	107,847	48,750	81,250	162,500	162,500	162,500	162,500	162,500	162,500	162,500	162,500	162,500	162,500	1,862,847	2,125,500	2,338,050
<u>CASH OUTFLOW</u>																
Administrative																

Expenditure								
Salary	8,956	8,956	8,956	8,956	8,956	8,956	8,956	8,956
EPF (13%)	1,365	1,365	1,365	1,365	1,365	1,365	1,365	1,365
SOSCO (2.3)	179	179	179	179	179	179	179	179
Wi-Fi	260	260	260	260	260	260	260	260
Building Rent	1,500	1,500	1,500	1,500	1,500	1,500	1,500	1,500
Bill	1,400	1,400	1,400	1,400	1,400	1,400	1,400	1,400
Office supplies	96	96	96	96	96	96	96	96
Marketing Expenditure								
Marketing personnel	2,000	2,000	2,000	2,000	2,000	2,000	2,000	2,000
Office supplies	96	96	96	96	96	96	96	96

8,956	8,956	8,956	8,956	8,956	107,467	107,467	107,467
1,365	1,365	1,365	1,365	1,365	16,380	16,380	16,380
179	179	179	179	179	2,153	2,153	2,153
260	260	260	260	260	3,120	3,120	3,120
1,500	1,500	1,500	1,500	1,500	18,000	18,000	18,000
1,400	1,400	1,400	1,400	1,400	16,800	16,800	16,800
96	96	96	96	96	1,146	1,146	1,146
2,000	2,000	2,000	2,000	2,000	24,000	24,000	24,000
96	96	96	96	96	1,146	1,146	1,146

Operations Expenditure						
Cash Purchase	8,104	8,104	8,104	8,104	8,104	8,104
Payment of Account Payable		10,805	18,909	18,909	18,909	18,909
Carriage Inward & Duty	400	400	400	400	400	400
Salaries, EPF & SOCSO	9,000	9,000	9,000	9,000	9,000	9,000
Vending machine products						
Other Expenditure	750					
Pre-Operations						
Deposit (rent, utilities, etc.)						
Business Registration & Licences	300					
Insurance & Road Tax for Motor Vehicle	650					

8,104	8,104	8,104	8,104	8,104	8,104	97,247	97,247	97,247
18,909	18,909	18,909	18,909	18,909	18,909	199,896	226,909	226,909
400	400	400	400	400	400	4,800	4,800	4,800
9,000	9,000	9,000	9,000	9,000	9,000	108,000	108,000	108,000
						750	750	750
						300		
						650	650	650

BEGINNING CASH BALANCE		58,807	72,700	109,037	218,521	328,005	437,488	546,972	656,456	765,939	875,423	984,907	1,094,391		1,203,874	2,691,949
ENDING CASH BALANCE	58,807	72,700	109,037	218,521	328,005	437,488	546,972	656,456	765,939	875,423	984,907	1,094,391	1,203,874	1,203,874	2,691,949	4,392,745

FINANCIAL ANALYSIS

SERAI LAUNDRY SERVICES			
FINANCIAL RATIO ANALYSIS			
	Year 1	Year 2	Year 3
<u>LIQUIDITY</u>			
Current Ratio	52	108	171
Quick Ratio (Acid Test)	52	108	171
<u>EFFICIENCY</u>			
Inventory Turnover			
<u>PROFITABILITY</u>			
Gross Profit Margin			
Net Profit Margin	66.15%	69.95%	72.69%
Return on Assets	90.20%	51.35%	37.05%
Return on Equity	93.07%	51.98%	37.27%
<u>SOLVENCY</u>			
Debt to Equity	3.18%	1.23%	0.59%
Debt to Assets	3.08%	1.22%	0.58%
Time Interest Earned	2,523	4,404	10,069

CURRENT RATIO

Current Ratios

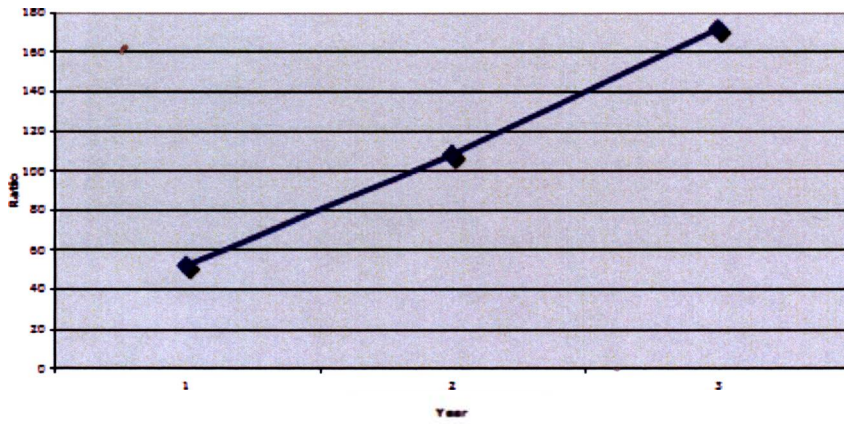

QUICK RATIO(ACID TEST)

Quick Ratios

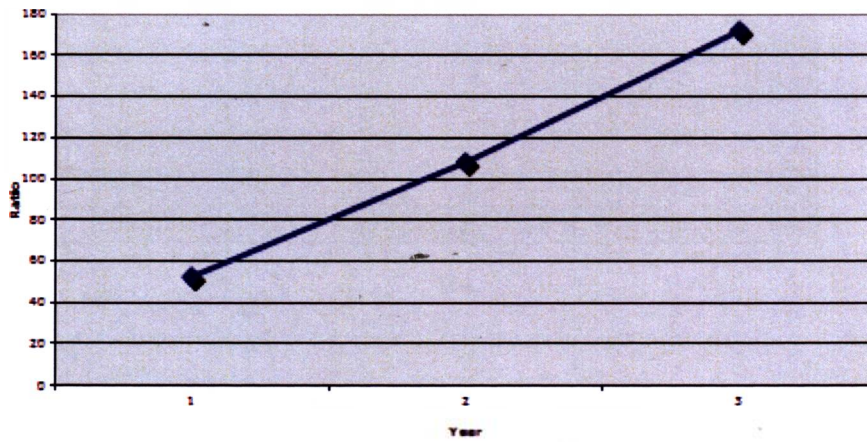

NET PROFIT MARGIN

Net Profit Margin

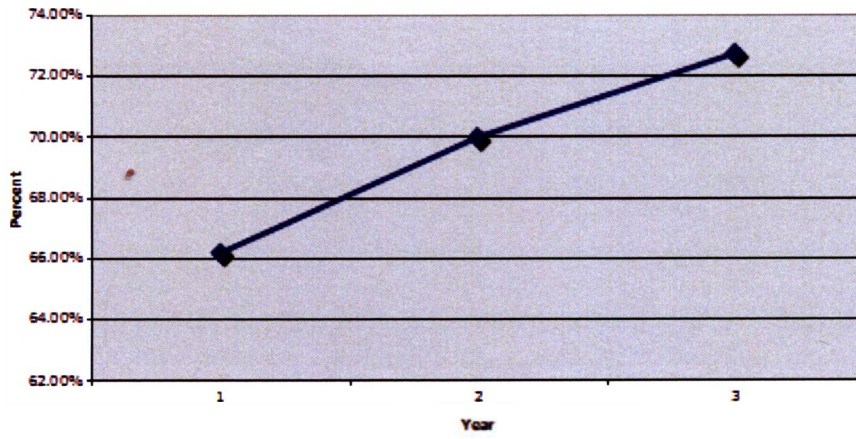

RETURN ON ASSETS

Return on Assets

Chart Area

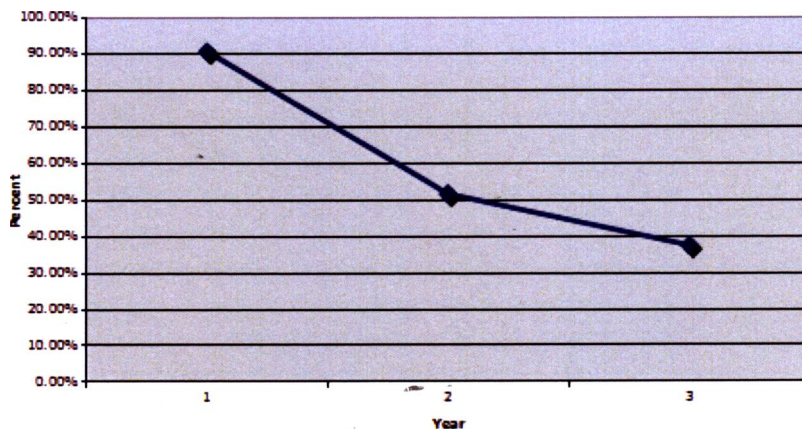

RETURN ON EQUITY

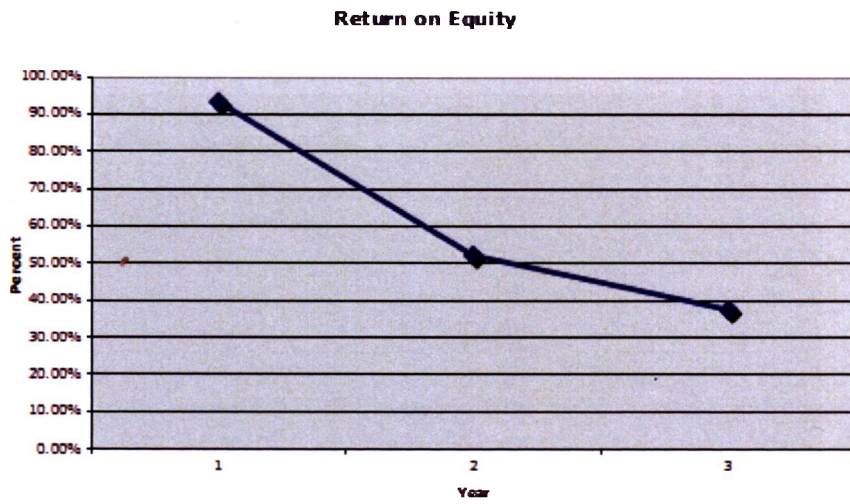

DEBT OF EQUITY

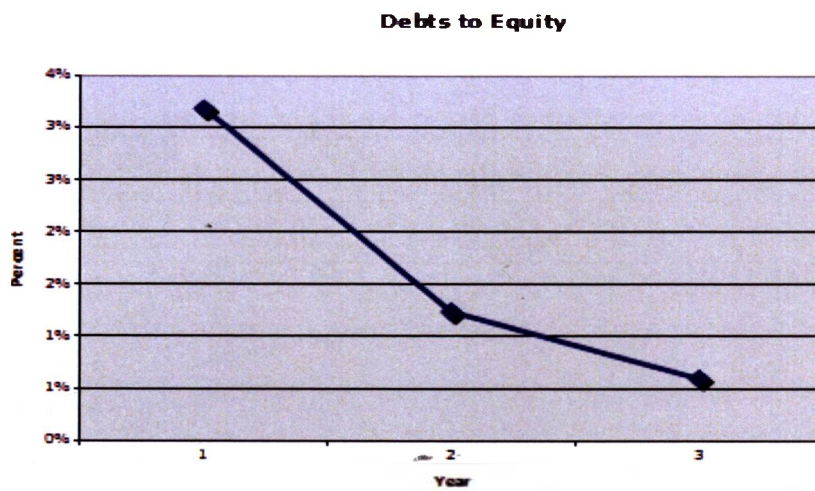

DEBT TO ASSETS

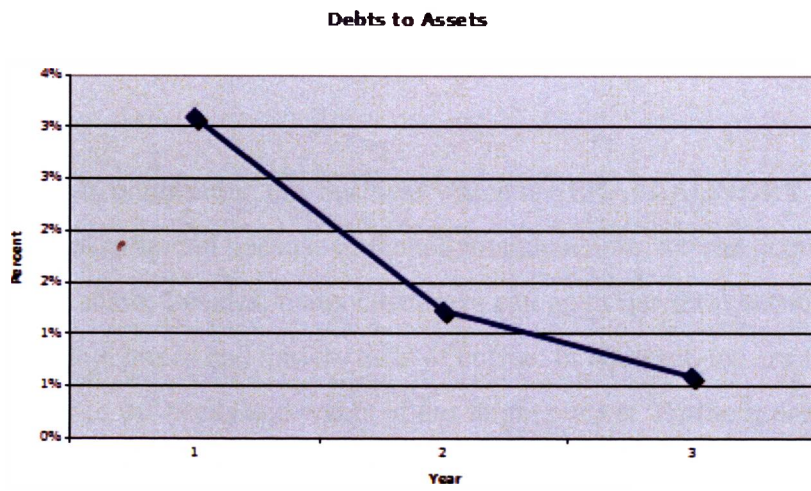

TIME INTEREST EARNED

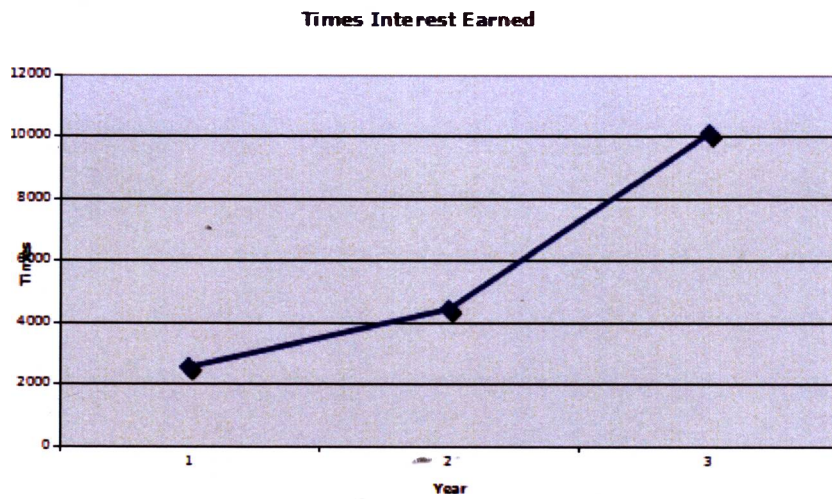

CONCLUSION

In conclusion, our business which is SERAI LAUNDRY SERVICES has the potential to spread because in Kota Samarahan area, we can acquire the maximum market share. Besides, many customers can go to our shop because we provide an affordable prices and variety taste of coffee. In addition, we are sure that we are able to cater to the needs and wants of our target market. Furthermore, we also hope that our products can enter the international market in years ahead. We will give all of our efforts to make this hope come true.