

ENT600

TECHNOLOGY BLUEPRINT



MULTIPURPOSE PORTABLE TABLE

Faculty	:	ENGINEERING (CHEMICAL)	
Program Code	:	EH 220	
Group	:	G	
Course	:	TECHNOLOGY ENTREPRENEURSHIP	
Semester	:	Seven (7)	
Group Members	:	1. AZIDORA BINTI AZMAN	2016250174
		2. AHMAD ZUHAIR BIN AHMAD ZAIDI	2016250188
		3. NURSHAFFIN AIDA BINTI RAMLAN	2016250192
		4. ARINA BINTI ABDUL GANI	2016250256
		5. NUR AFIQAH BINTI MUHAMAD KAMIL	2016250198

Submitted to:

ADLAN AHMAD BAKRI

Submission Date:

31 DECEMBER 2019

Table of Contents

EXECUTIVE SUMMARY.....	1
1.0 THE COMPANY.....	2
2.0 PRODUCT DESCRIPTION	3
3.0 TECHNOLOGY DESCRIPTION.....	6
4.0 MARKET ANALYSIS AND STRATEGIES.....	7
4.1 Customers.....	7
4.2 Competition and Competitive Edges.....	7
4.3 Marketing Strategies	8
5.0 MANUFACTURING & OPERATIONS.....	10
5.1 Process Manufacturing of Multipurpose Portable Table	10
6.0 FINANCIAL ESTIMATION.....	11
6.1 Start-Up Cost.....	11
6.2 Working Capital.....	12
6.3 Start-Up Capital And Financing.....	13
7.0 PROJECT MILESTONES.....	14
8.0 BUSINESS EXIT STRATEGY.....	15
REFERENCE.....	16



EXECUTIVE SUMMARY

In this report, the objective is to prepare a successful business plan by taking into considerations from all aspect. Le Pratique Company Sdn. Bhd. is a new developed company that release a new product called "Multipurpose Portable Table". Initially, the basic idea of this product is to provide a pocket file that fit various things such as laptop, stationary and files or books. Eventually, new idea arises with the demand of daily activities specifically who works in the state of mobilization. These people or consumers spent countless of hours in the coffee shops in search of space, atmosphere and also a table which are different from the likes of their home. Thus, the idea to develop this product is improved by allocate a mini table legs on it. The product innovation focuses to provide a simple and easy-to-carry mini table as well as providing an organized space for stuff. The design for this product is explain in details in Section 2.0. "Multipurpose Portable Table" is a consumer based product where it can be used by everyone. The target market for this project is mainly in Shah Alam, Selangor since the population in this area is high. Demand for a mini table nowadays is increased greatly that impact the competition between suppliers. Comparison is done with another two different types of product in order to improve the product that will be produce by this company. A review on the start-up cost and working capital cost are listed in Section 6.0. Since this company is owned by 5 entrepreneurs; the sources of capital will be shared among the owners. There is no fund or loan taken from the bank or other outside sources. This project is estimated to produce 1000 units of product within 3 months after 2 months of start-up the business. The project milestones are described is Section 7.0.

1.0 THE COMPANY

Le Pratique Company Sdn. Bhd. was founded in October 2019 and consists of 5 enthusiastic entrepreneurs with the vision of making life, simpler. The business that are self-managed and self-funded by these 5 entrepreneurs, started at the room of the college where the process of production and marketing are being executed. As demand of the product reach greater heights, a small space cum office was rented to manage the business necessity productively. The administrative, marketing, production and operation work of the company occurred in the office to gauge the market acceptance of the product. With the perception of being friends with its users, humble beginnings and being the "coolest company" in the hearts of its users, Le Pratique Company is committed to continuous innovation, with an unwavering focus on quality and efficiency. The company relentlessly builds amazing products with honest prices to let everyone in the world enjoy a better life through innovative technology. The company anticipated to establish a wide array of stress free, convenient and simple to use product that compliments our way of lives in the near future as it grows. Multipurpose portable table is currently the world's most anticipated lifestyle product which reduces daily hassle in transporting essential while keeping the fast paced life, undisturbed

2.0 PRODUCT DESCRIPTION

This product was designed to complement the people who are on the go while in dire need of space to those times where work has to be done on the spot. The idea and design of the product took place from the observation of daily activities specifically who works in the state of mobilization. These people or consumers spent countless of hours in the coffee shops in search of space, atmosphere and also a table which are different from the likes of their home. As shown in Figure 1, the product named as 'Multipurpose Portable Table' will be able to accommodate to those needs by doing just that. The incorporation of a laptop holder and laptop stand is the main combination behind the innovation of the product. Also, the company is bringing forth additional storage compartment to the product for other purposes such as to keep documents, stationary and mobile phones intact.

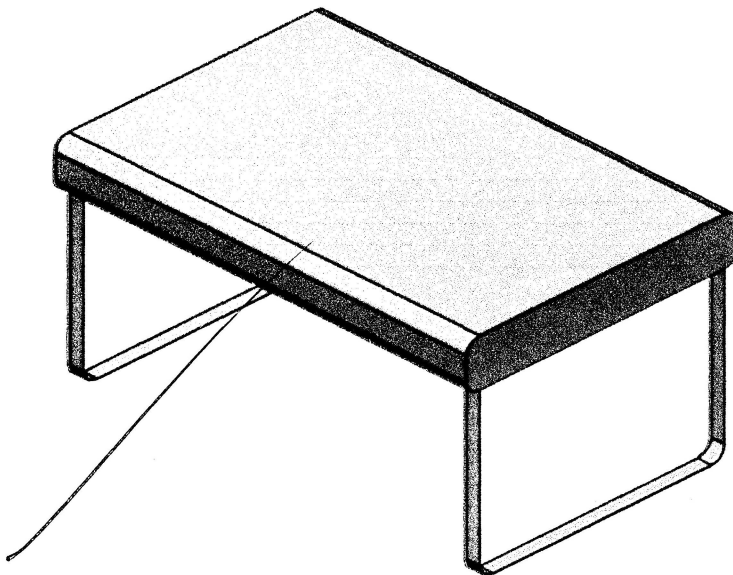

Figure 1: Isometric view of Multipurpose Portable Table.

Primarily, the intention to produce and commercialize the said product is due to the need of working space in congested eatery around the area of Shah Alam. The product as shown in Figure 2 is able to provide the working space needed while keeping the options open for the consumers to do their work with their choice of place due to the product portability. It also acts as a medium to safely store your laptop without having to bring it out separately on the other hand.